

CATÁLOGO DE DADOS EUROPEOS

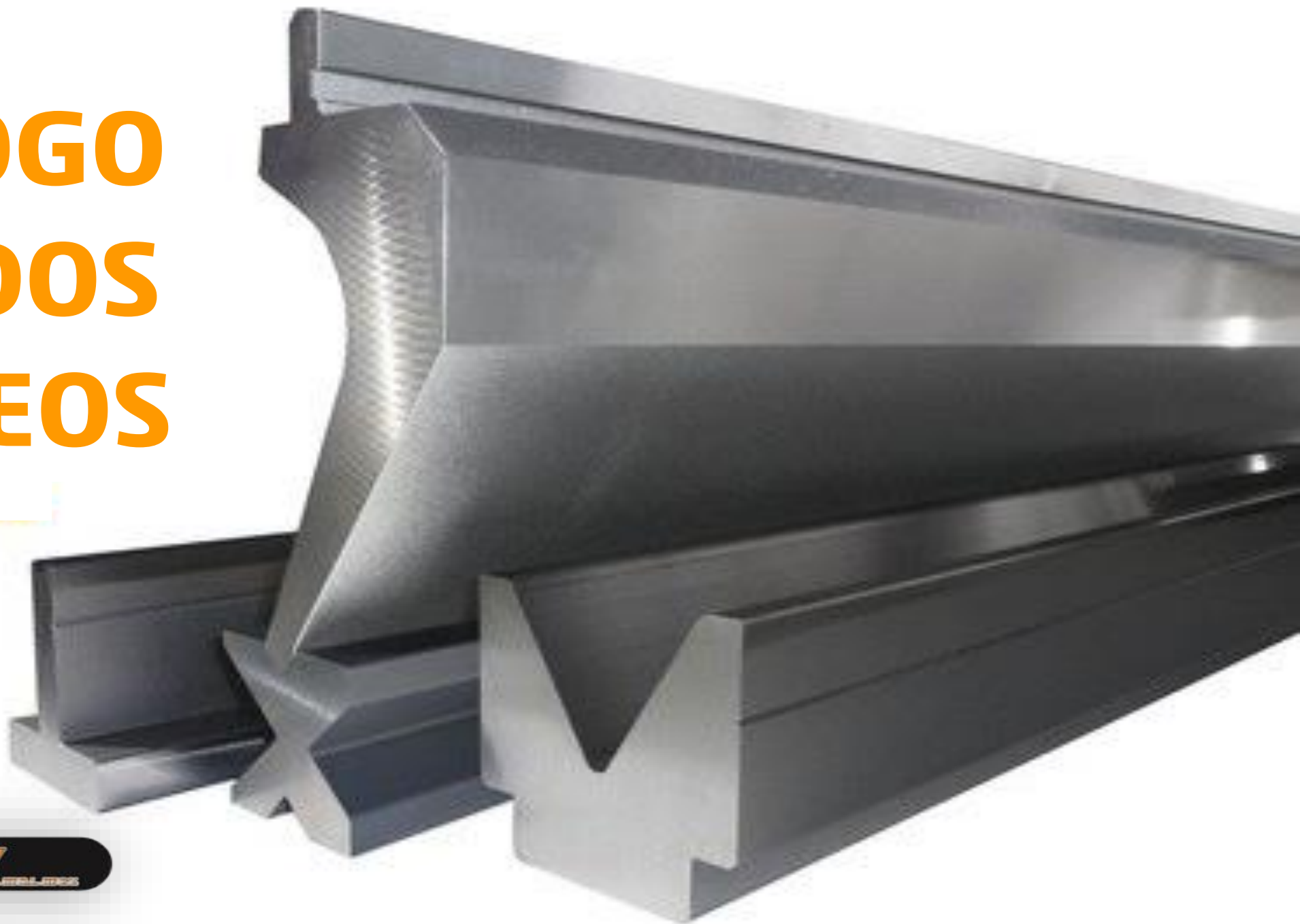

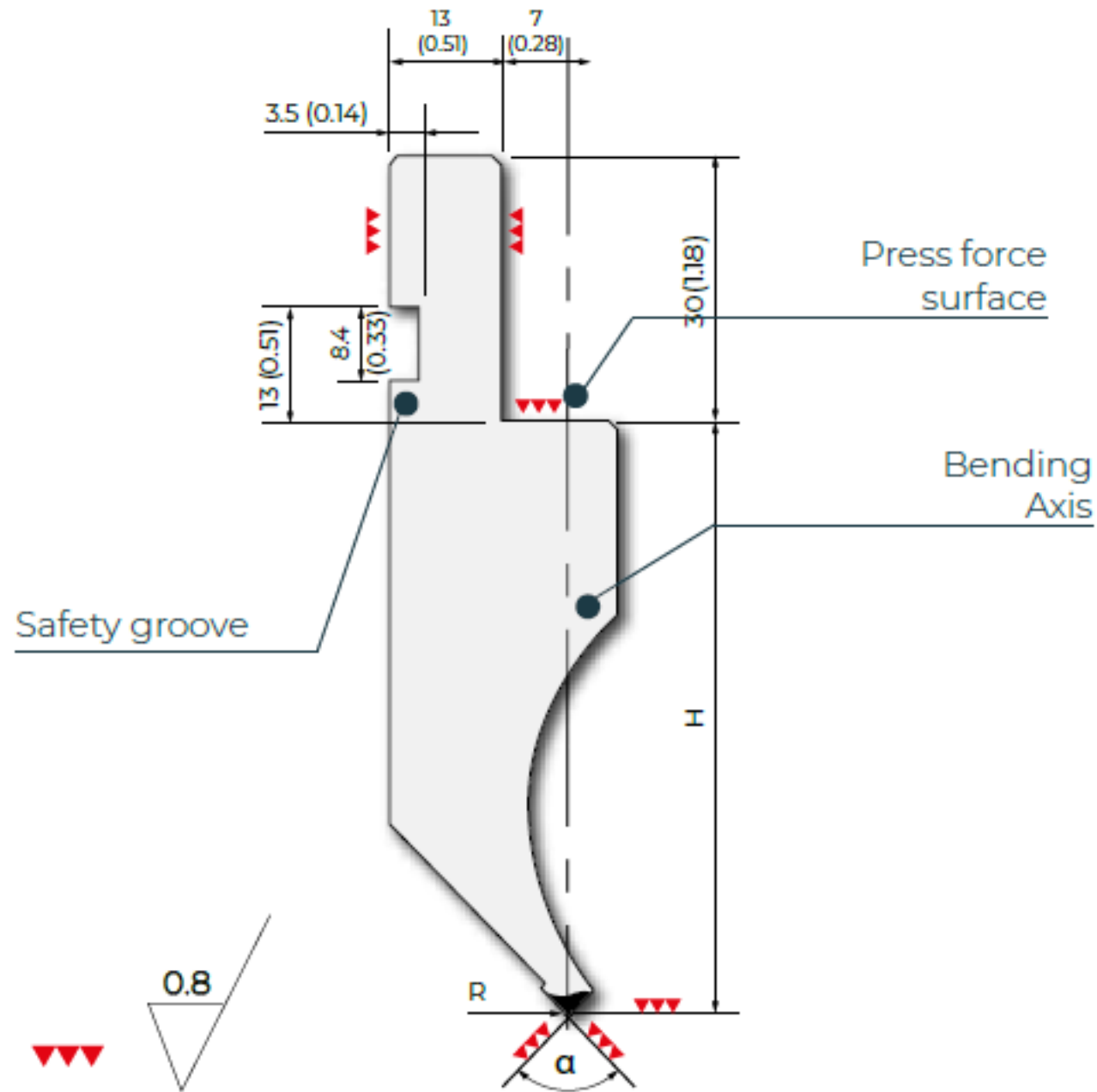

A1

Groove in addition to 8.4 x 3.5 mm

Groove for:

- Pneumatic clamping

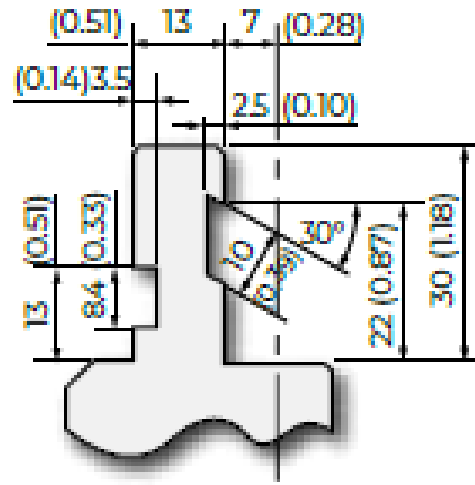
**A7**

Groove in addition to 8.4 x 3.5 mm

and shortened tang for:

- **R3**
- Bystronic-Beyeler Euro
- Safan

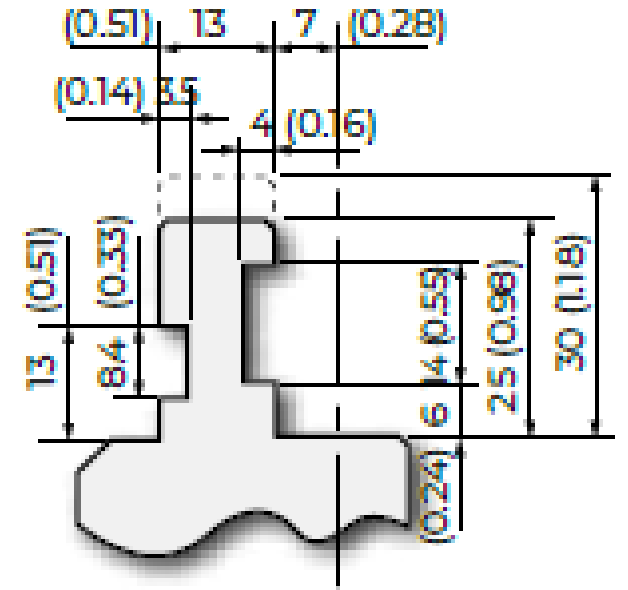
**A6**

Groove in addition to 8.4 x 3.5 mm

groove for:

- **R3**
- Bystronic-Beyeler Euro
- Safan

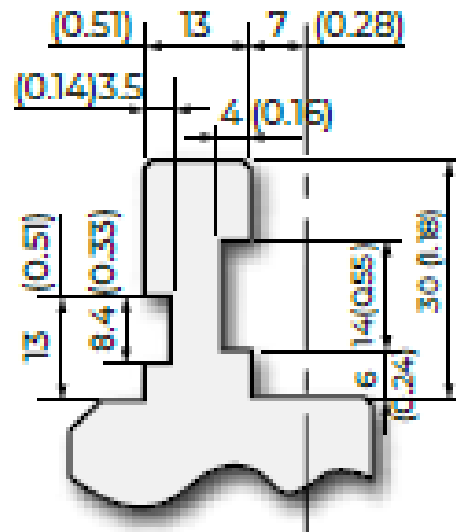
**A8**

Groove for:

- Hydraulic clamping
- Gasparini

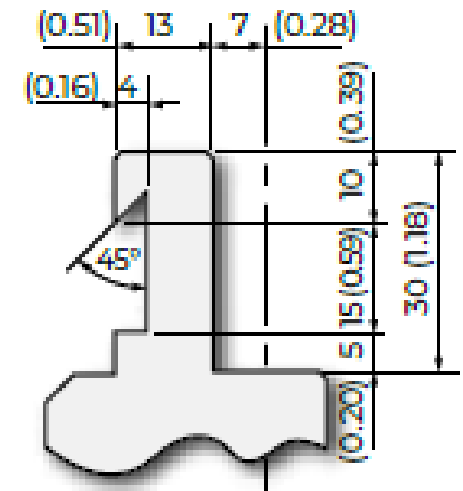

A9

Modified groove for:

- R2
- R3
- RX

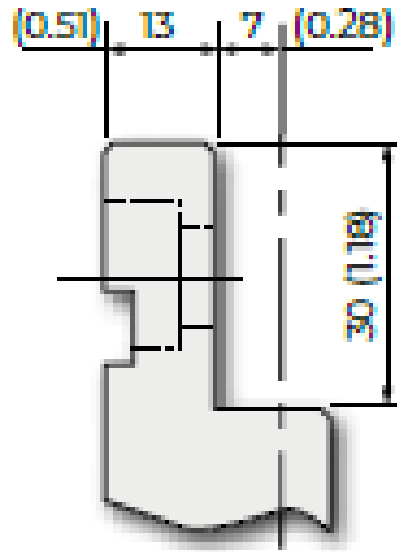

A42

Modified groove for:

- R3
- Bystronic-Beyeler Euro
- Safan

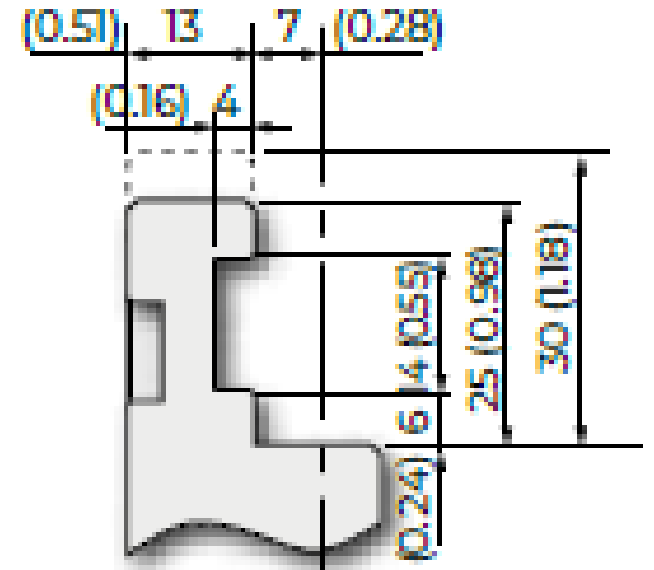

A41

Modified groove for:

- R3
- Bystronic-Beyeler Euro
- Safan

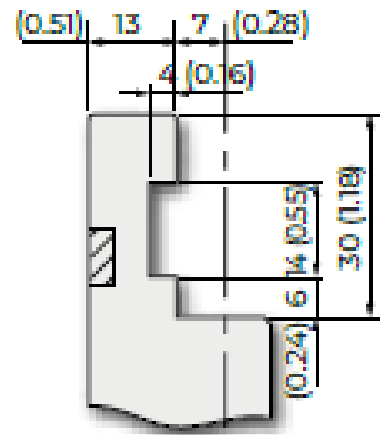

OT

Modification for:

- For Amada fast clamping system

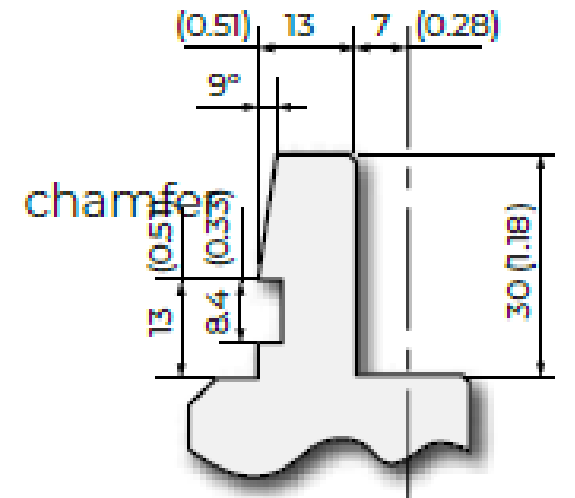

FA: 495 mm (19.49 in) - 8 segments

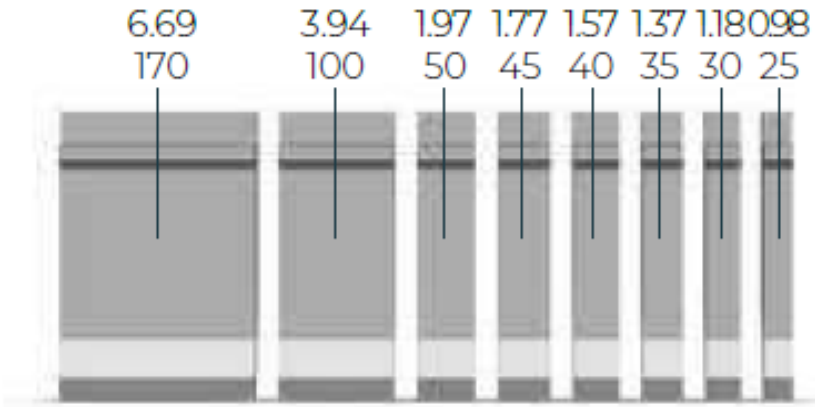

TOP - Horn types

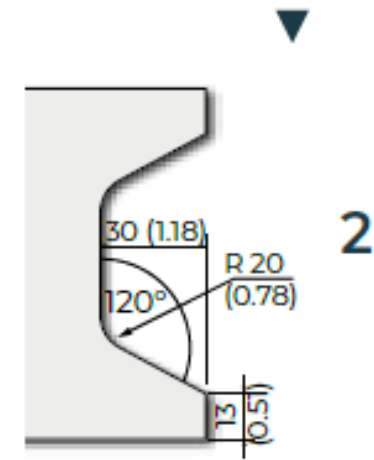

FB: 500 mm (19.68 in) - 3 segments

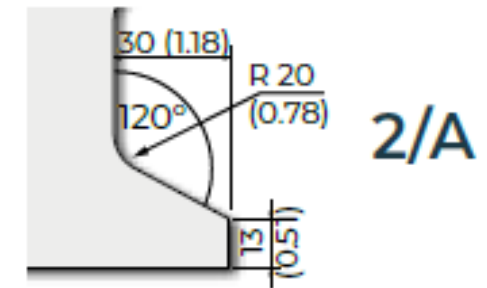

F: 805 mm (31.69 in) - 9 segments

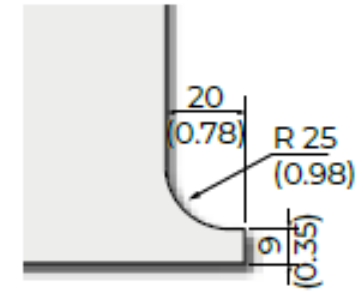
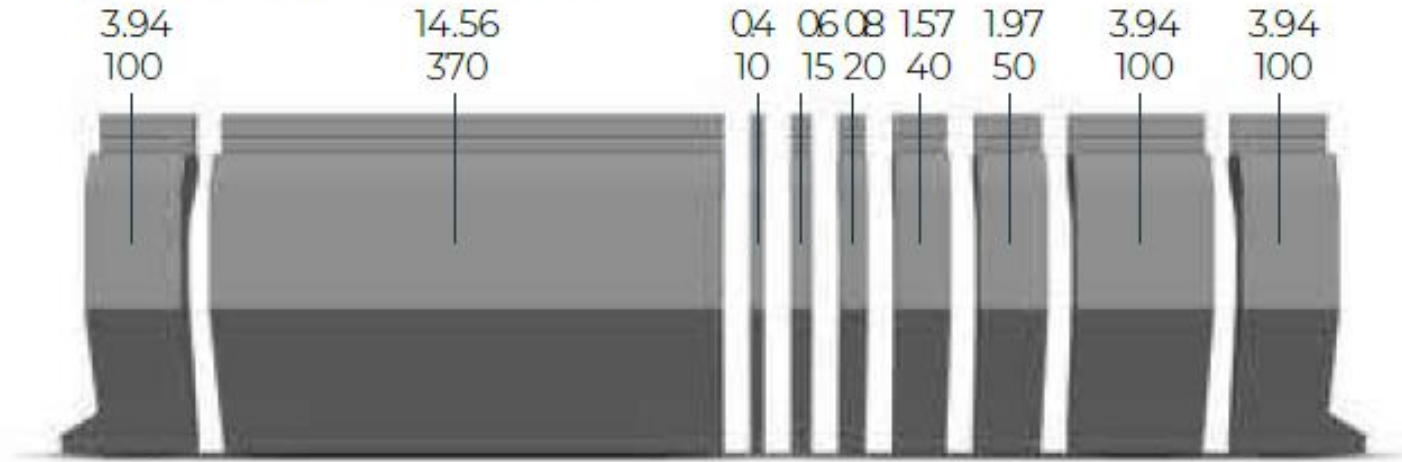

1

FX: 795 mm (31.29 in) - 11 segments

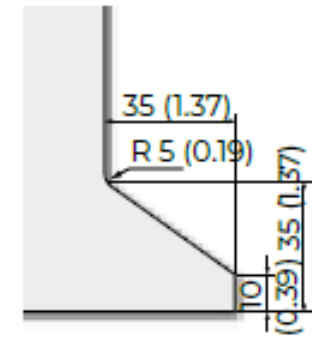
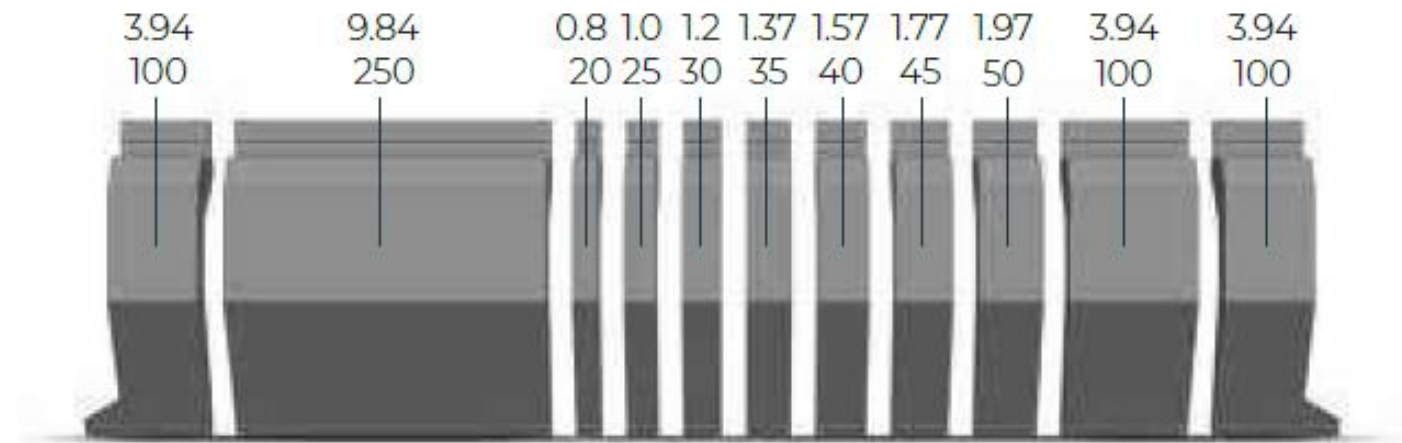

3

R1-A

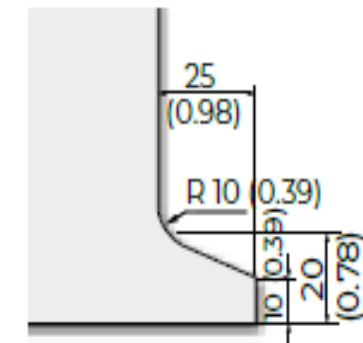

4

R1-A

FC: 800 mm (31.50 in) - 9 segments

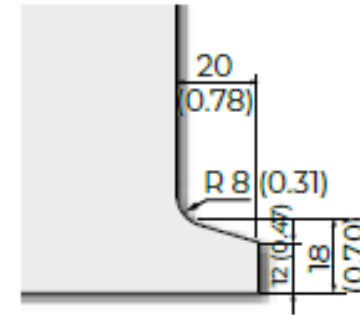
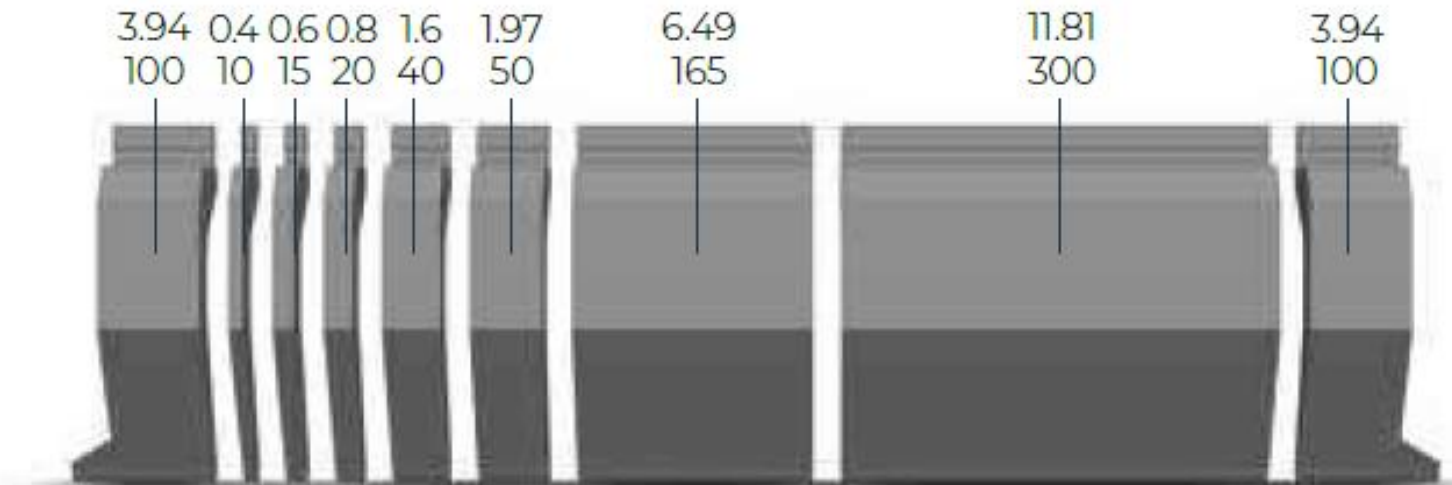

5
R1-A

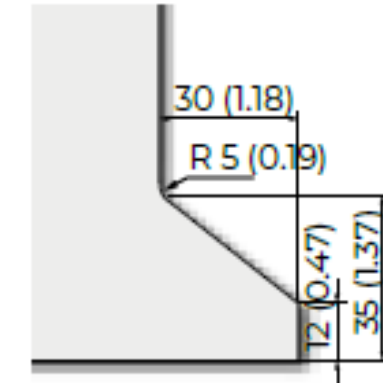

6
R1-A

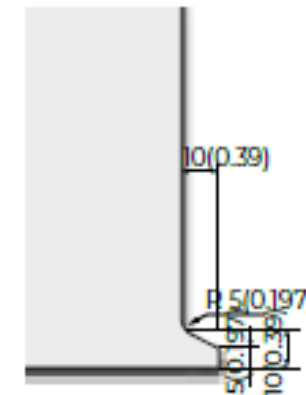

7
R1-A

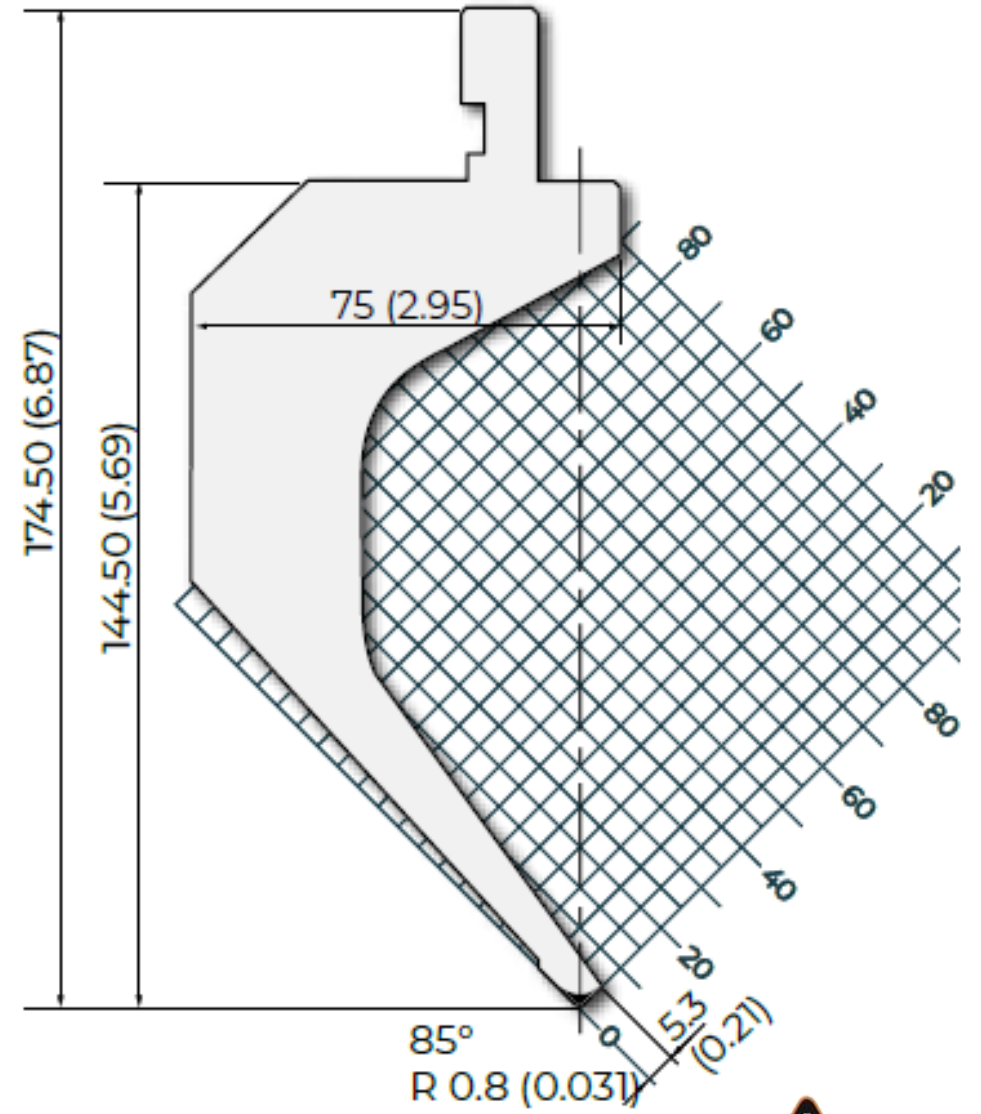
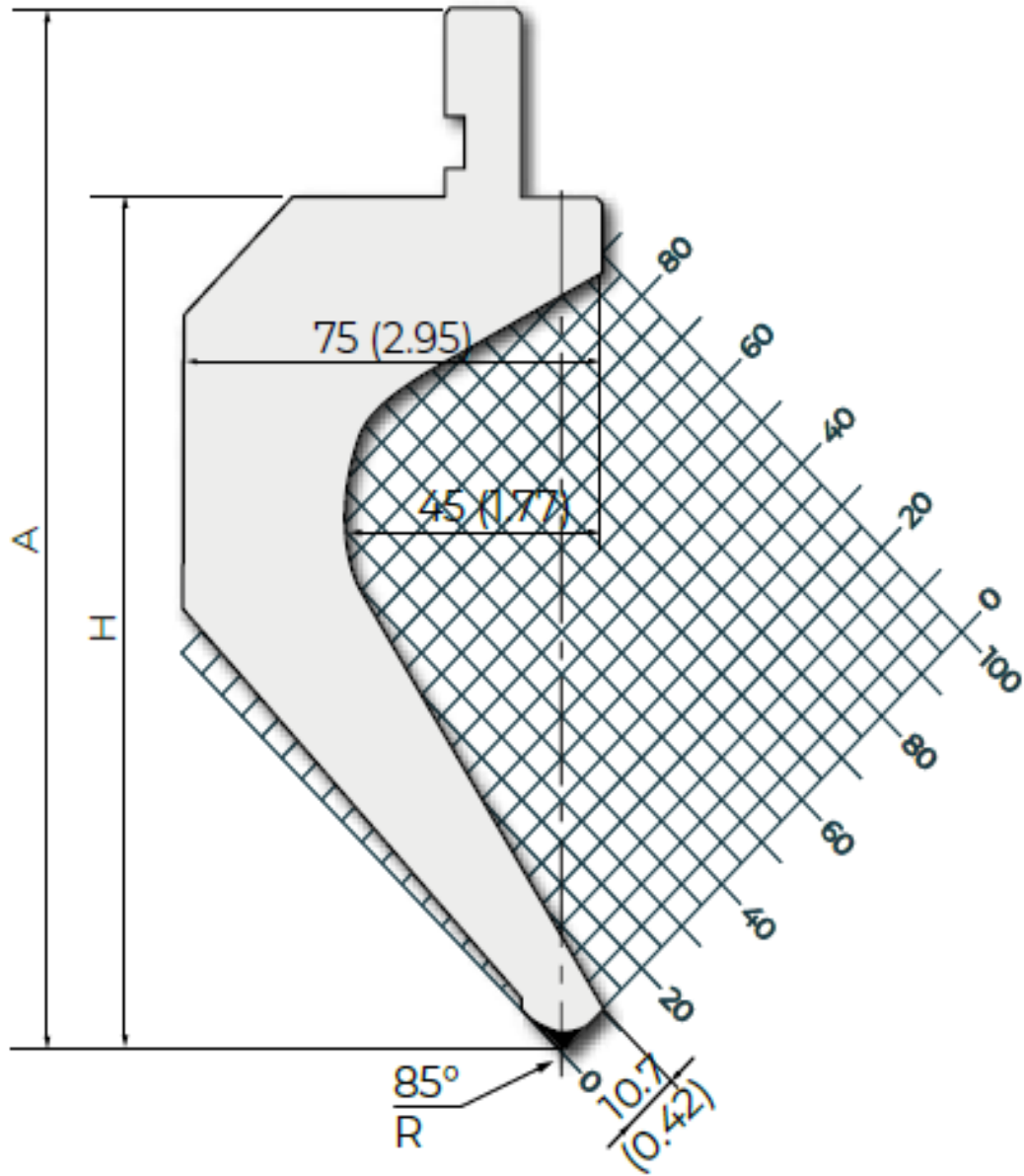

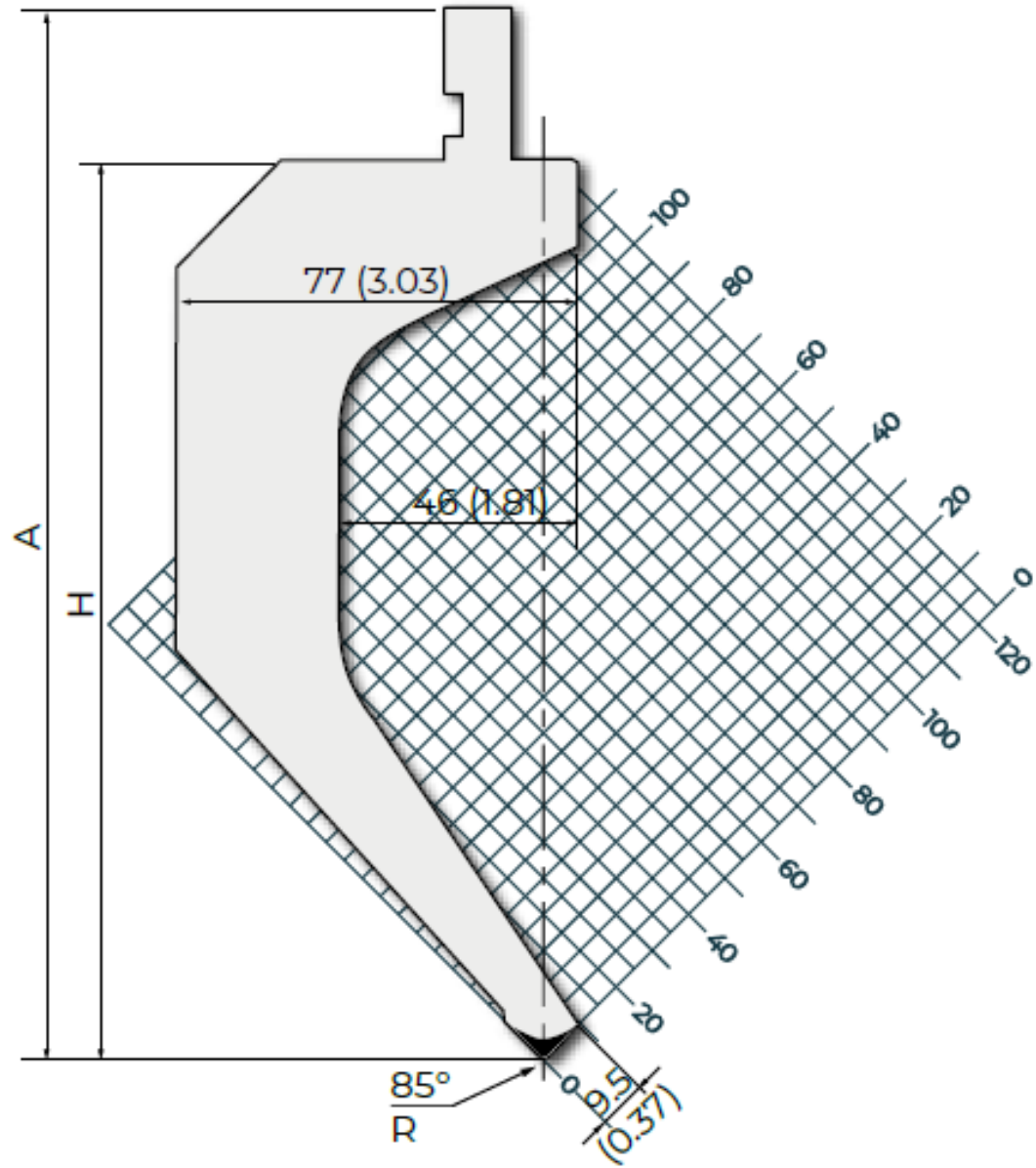

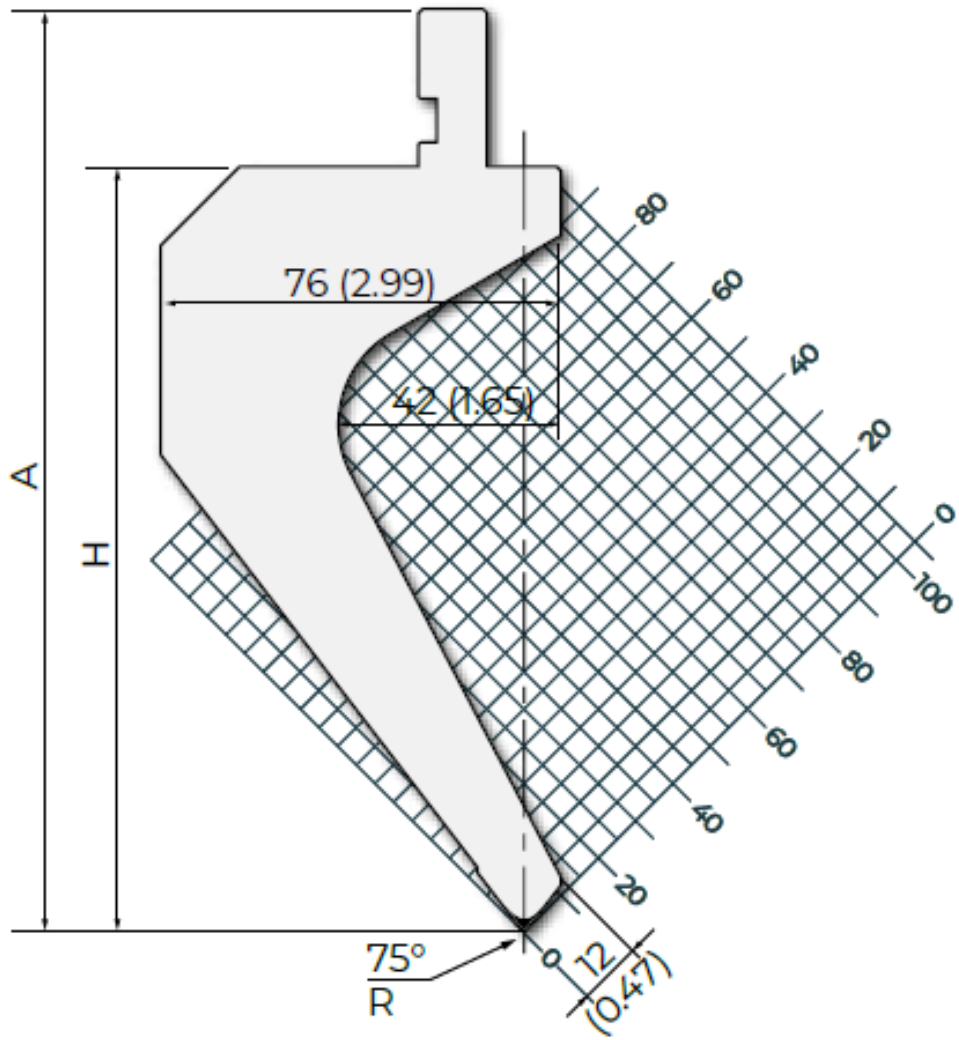

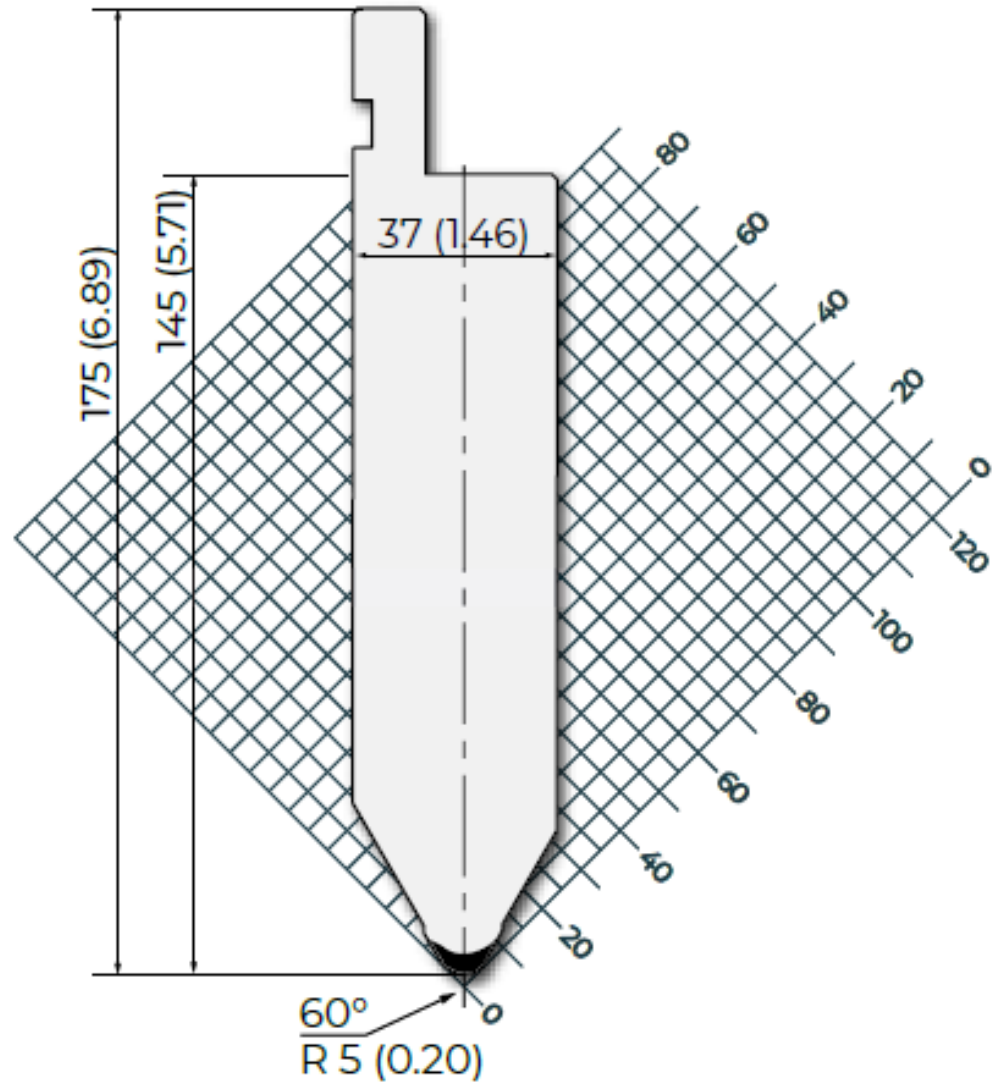
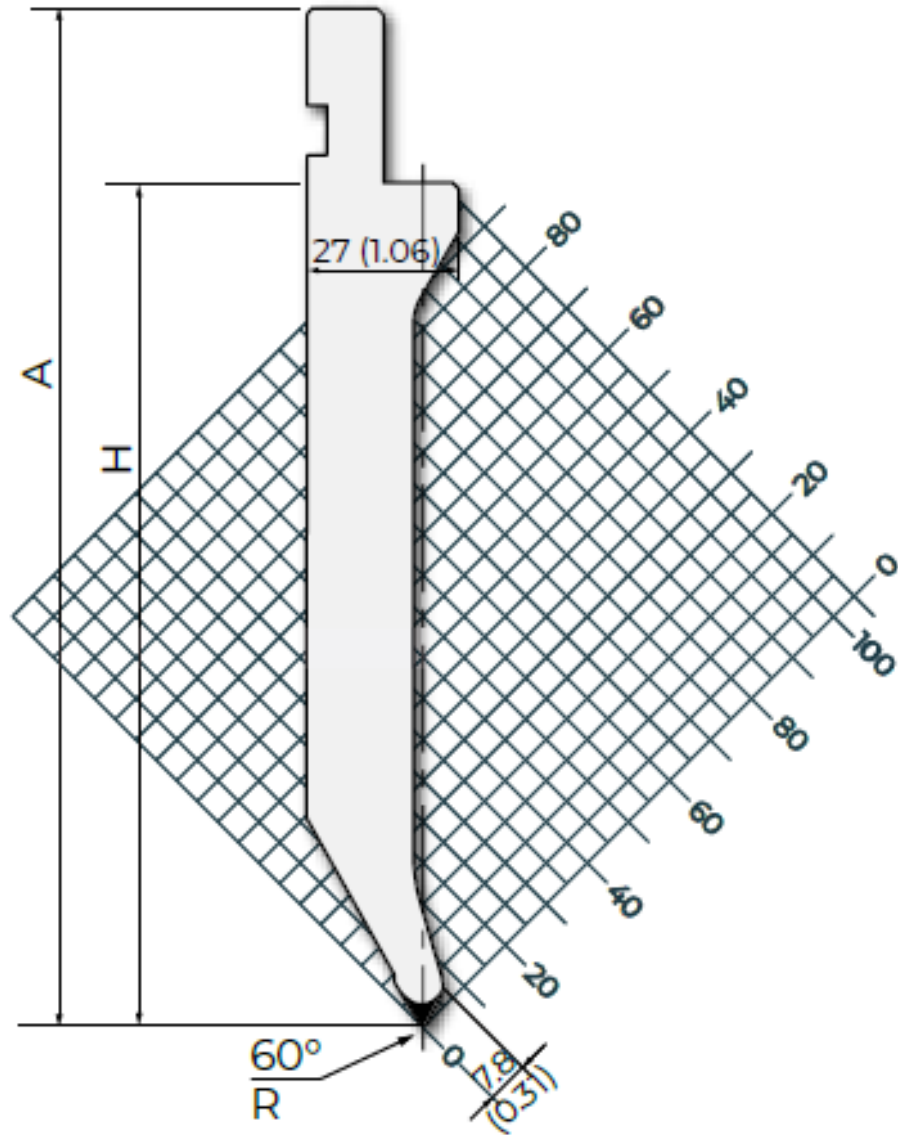

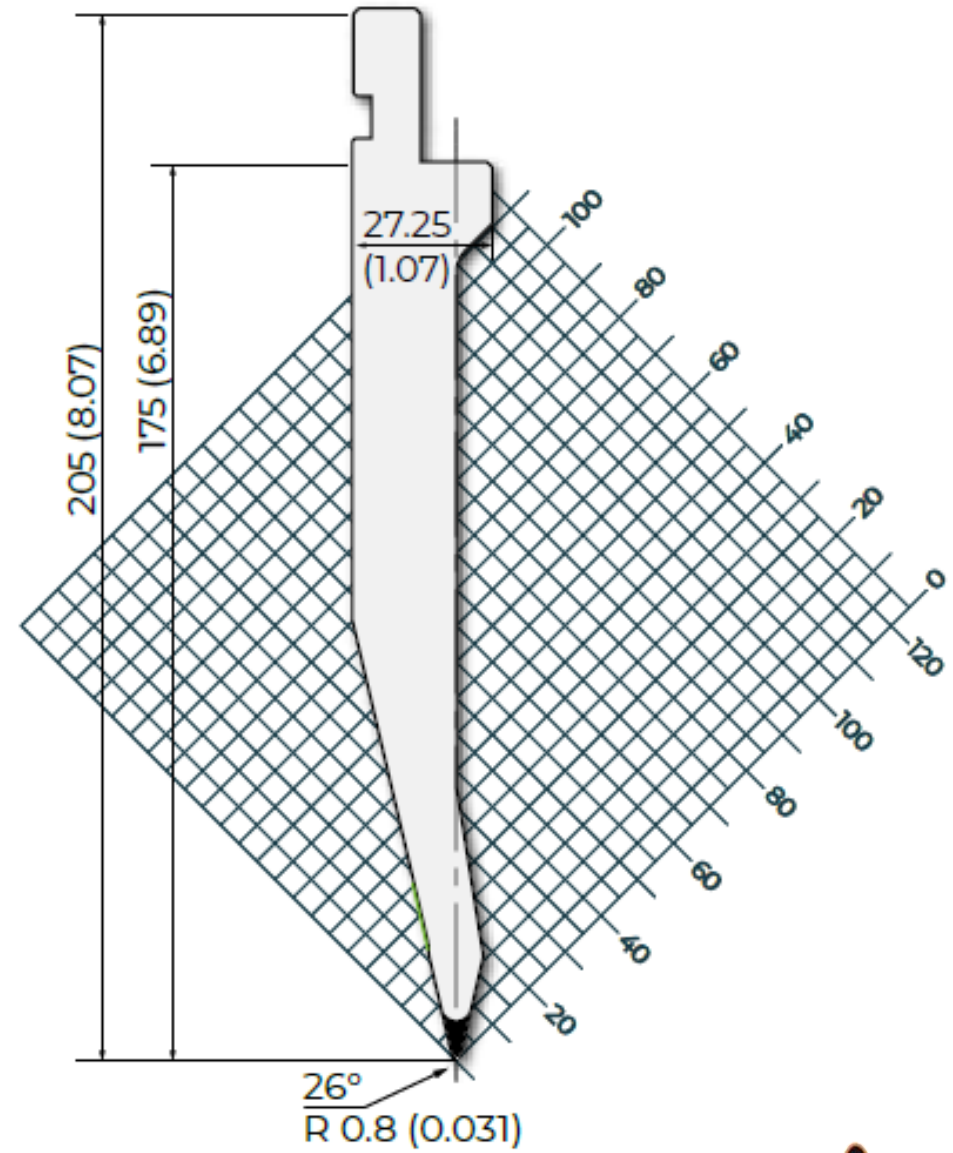
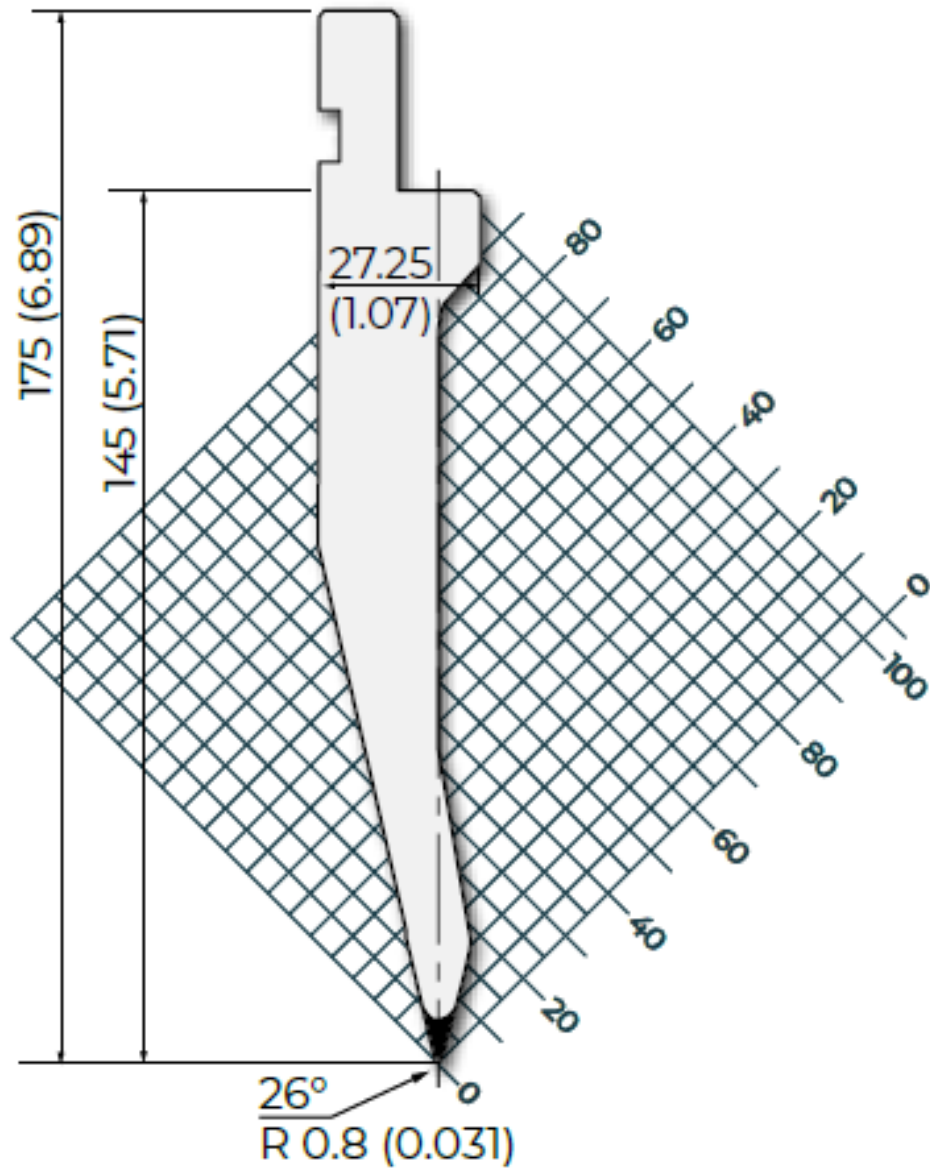

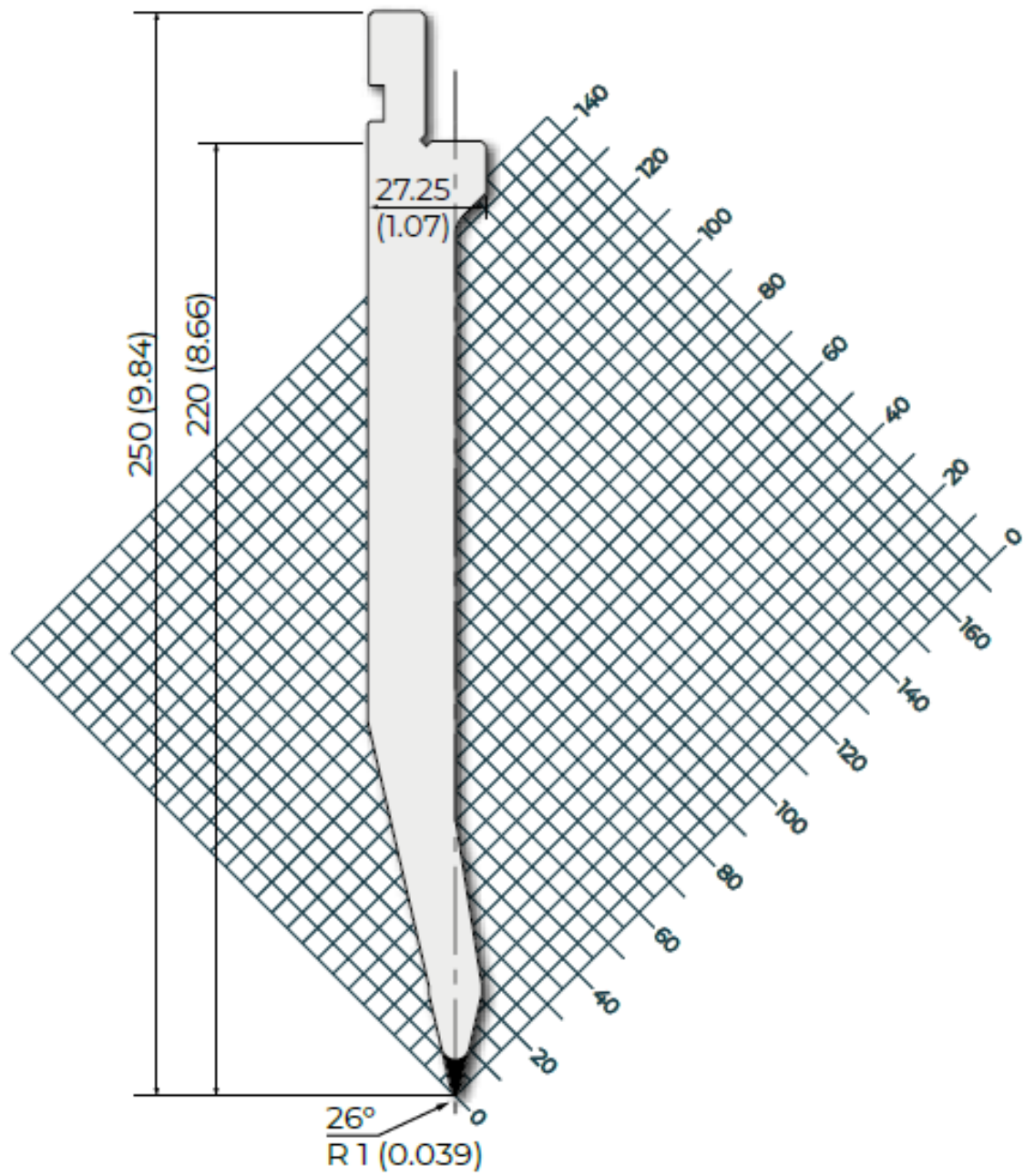

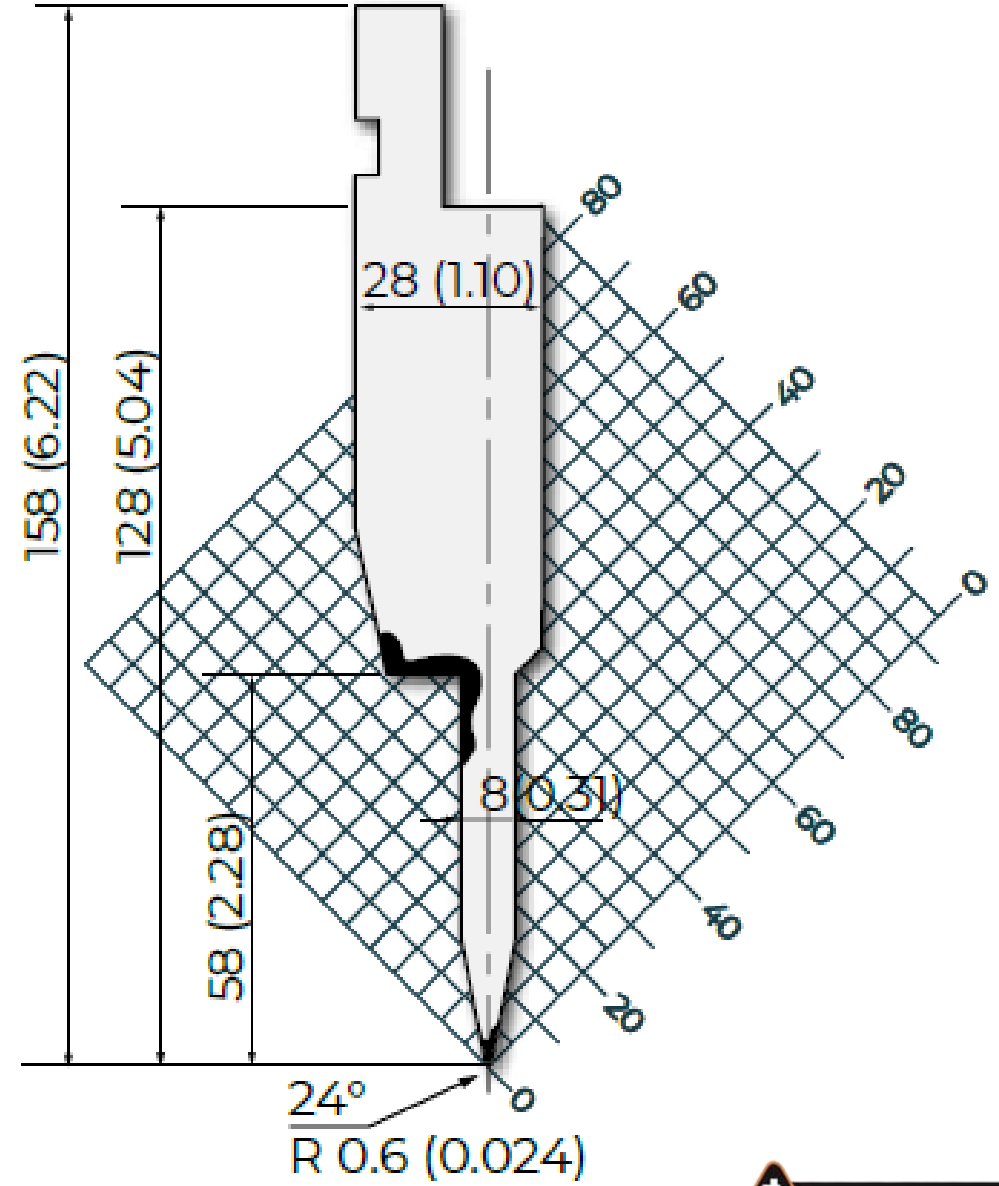
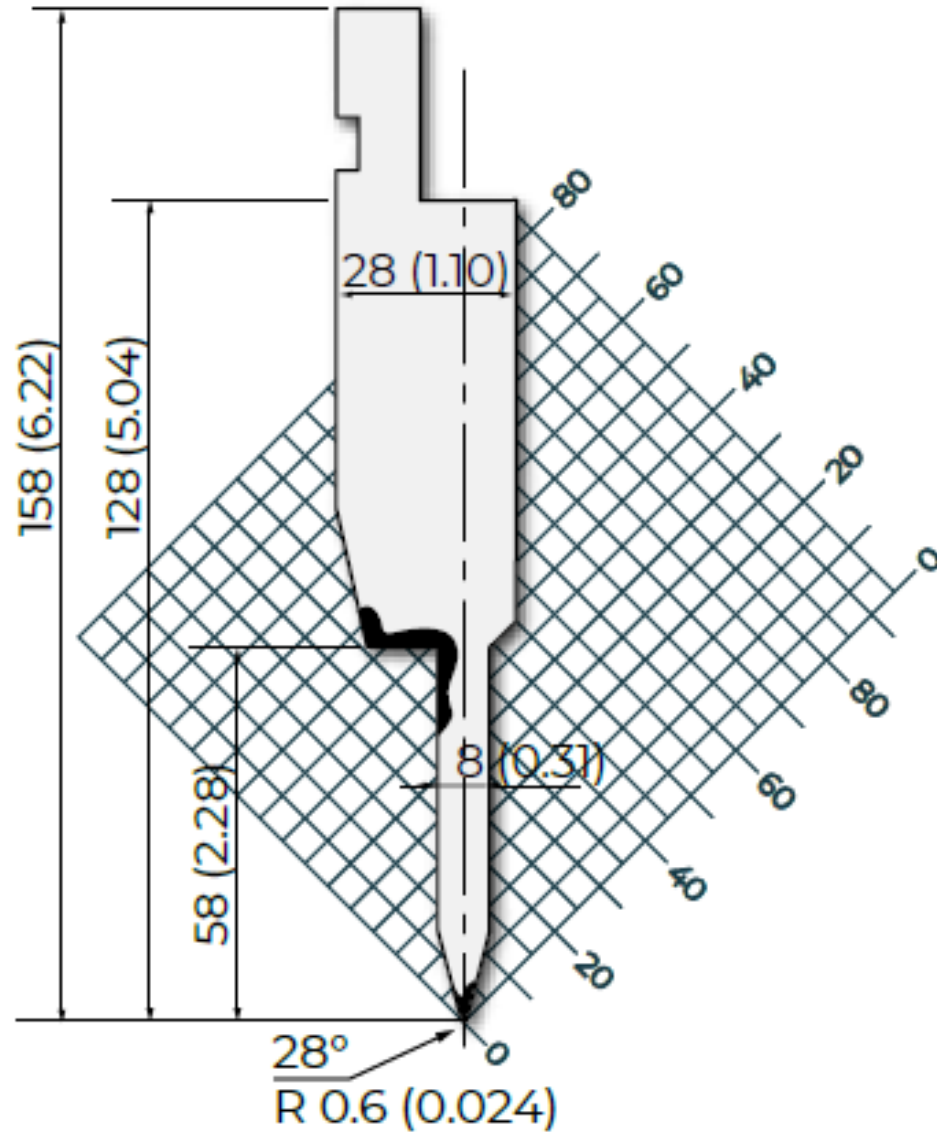

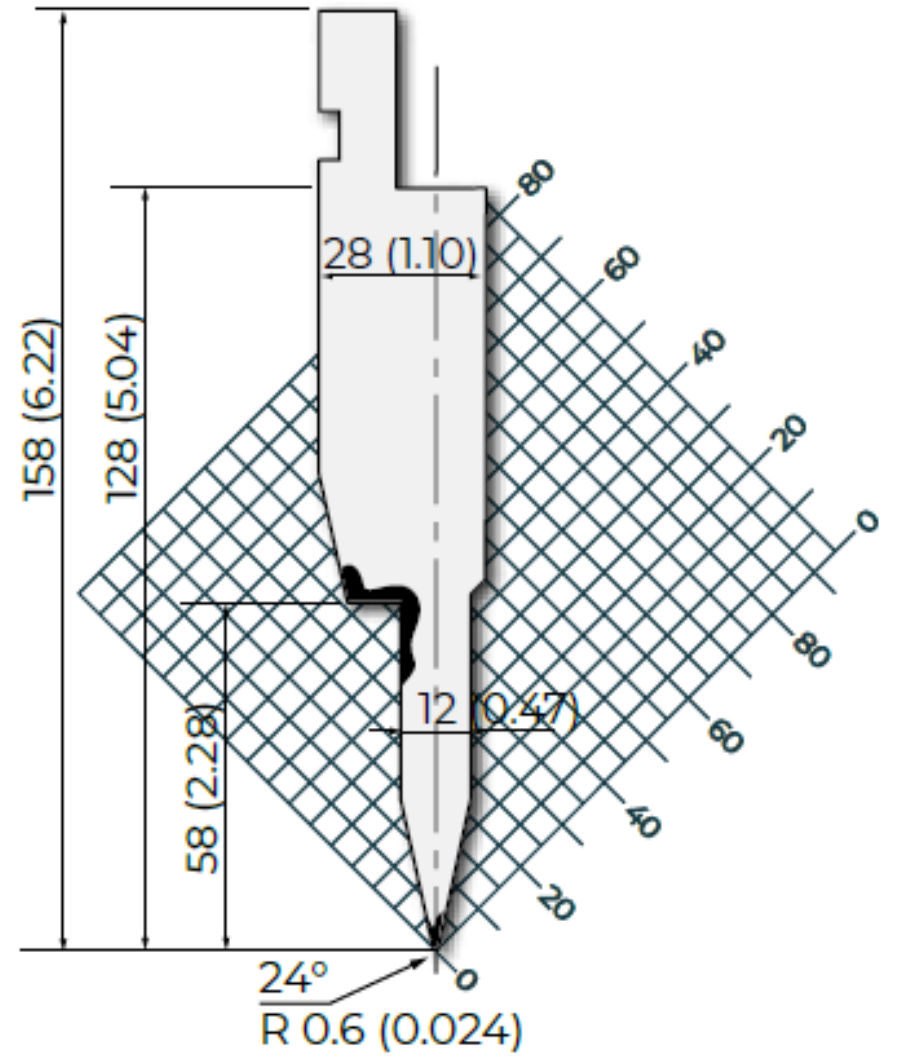
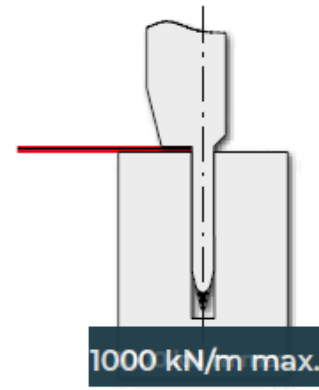
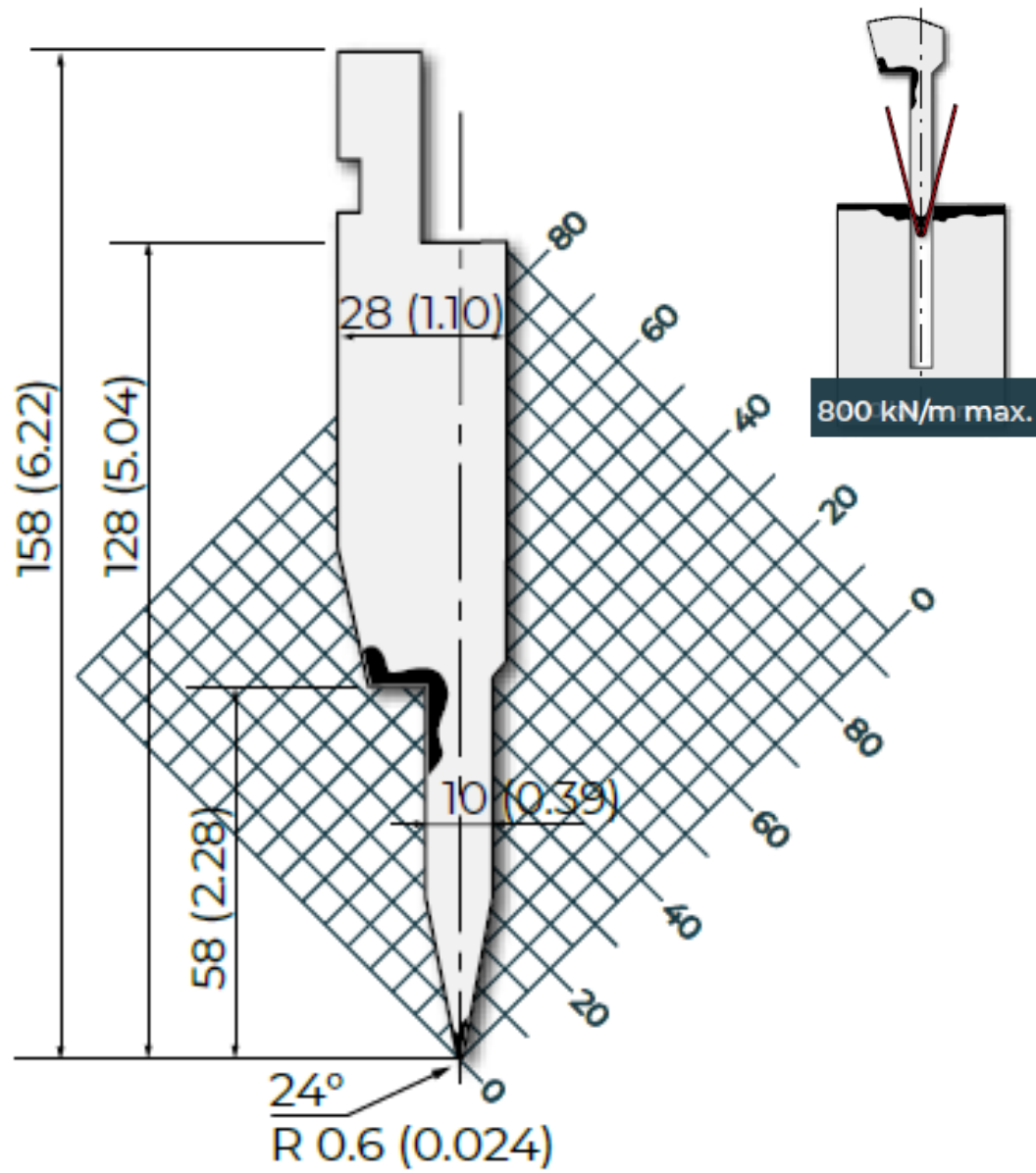

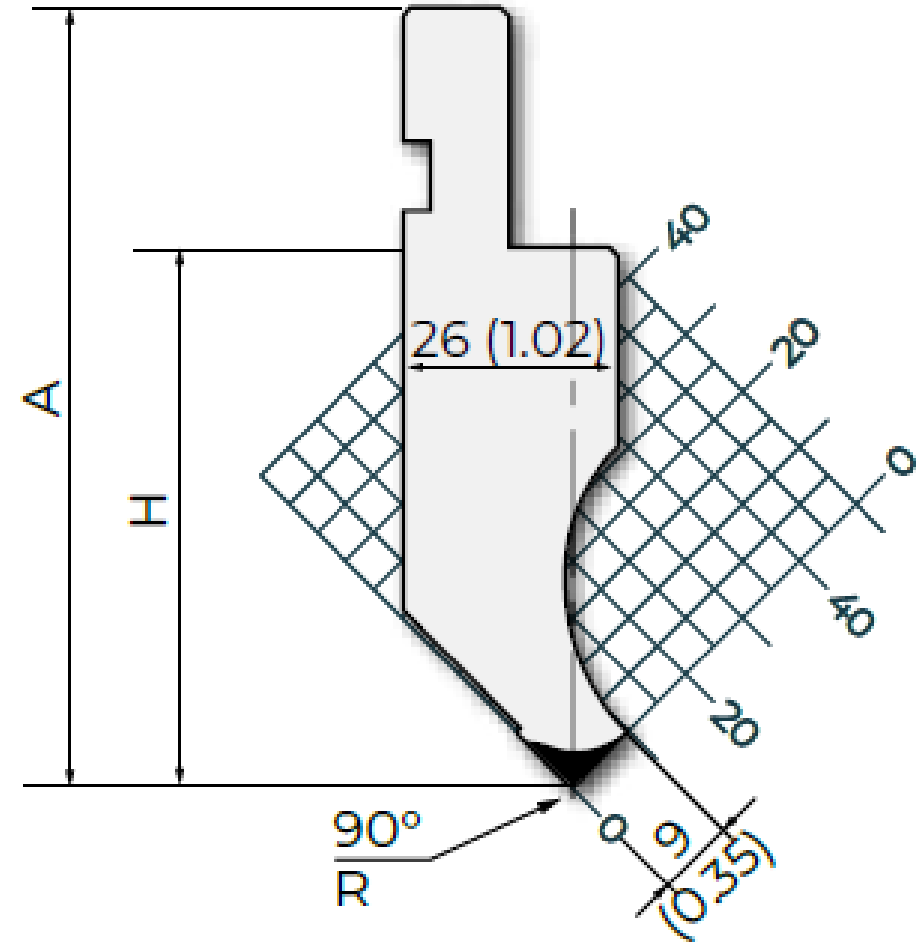
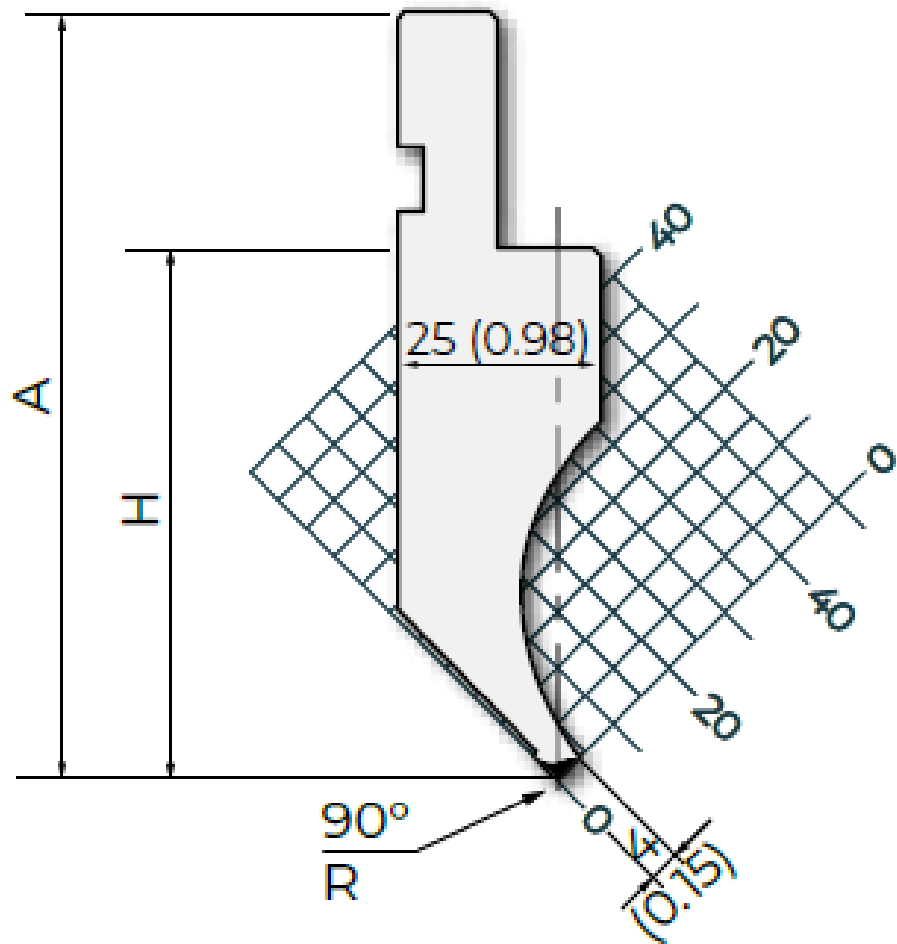

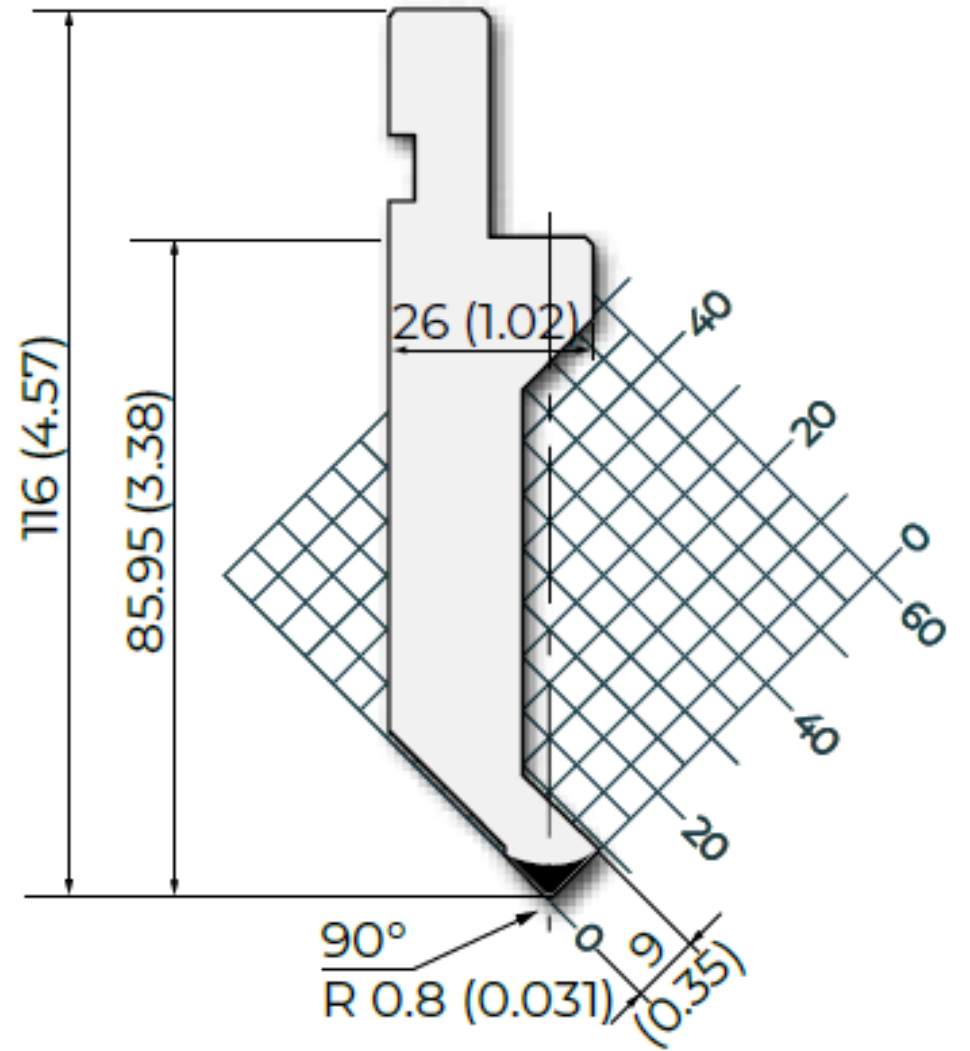
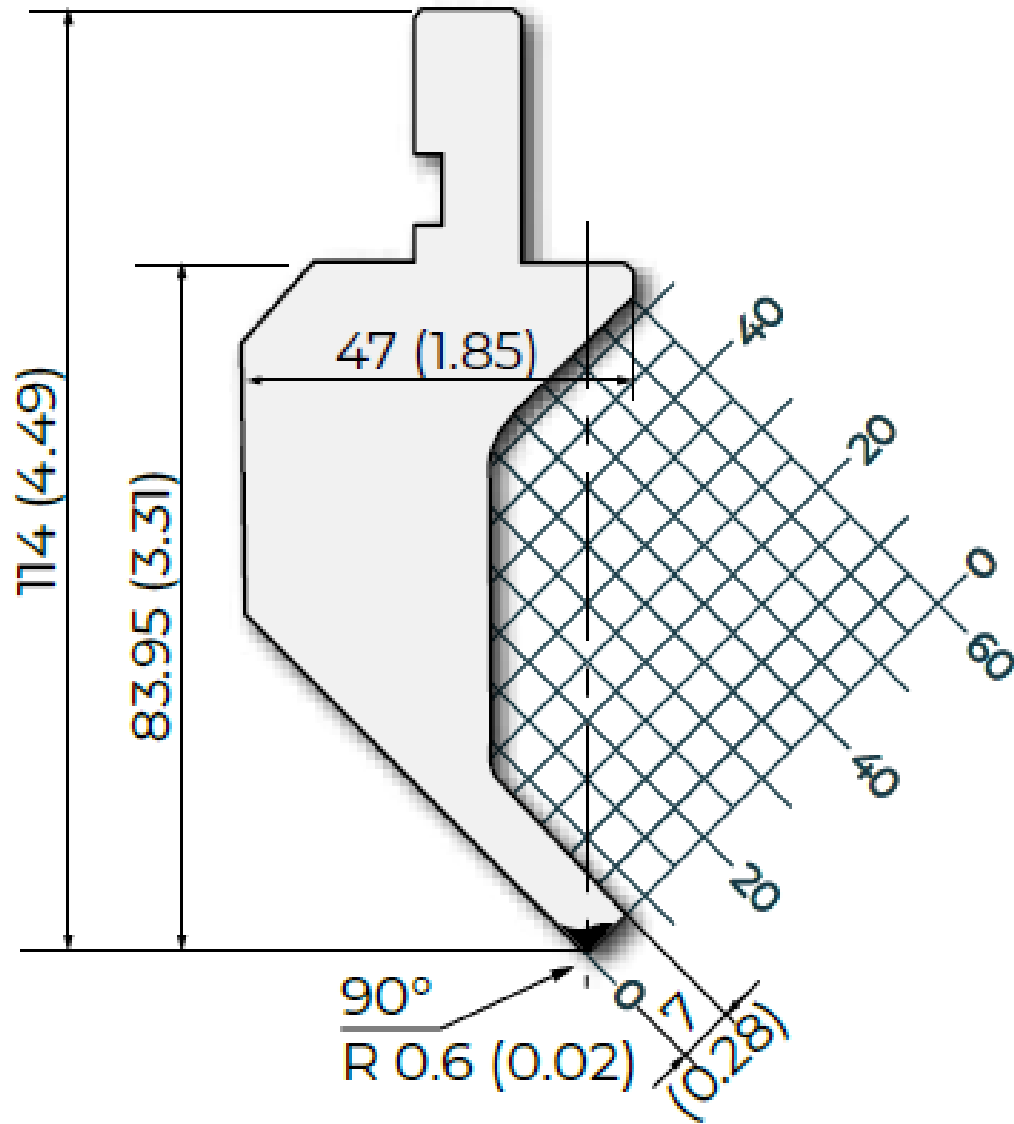

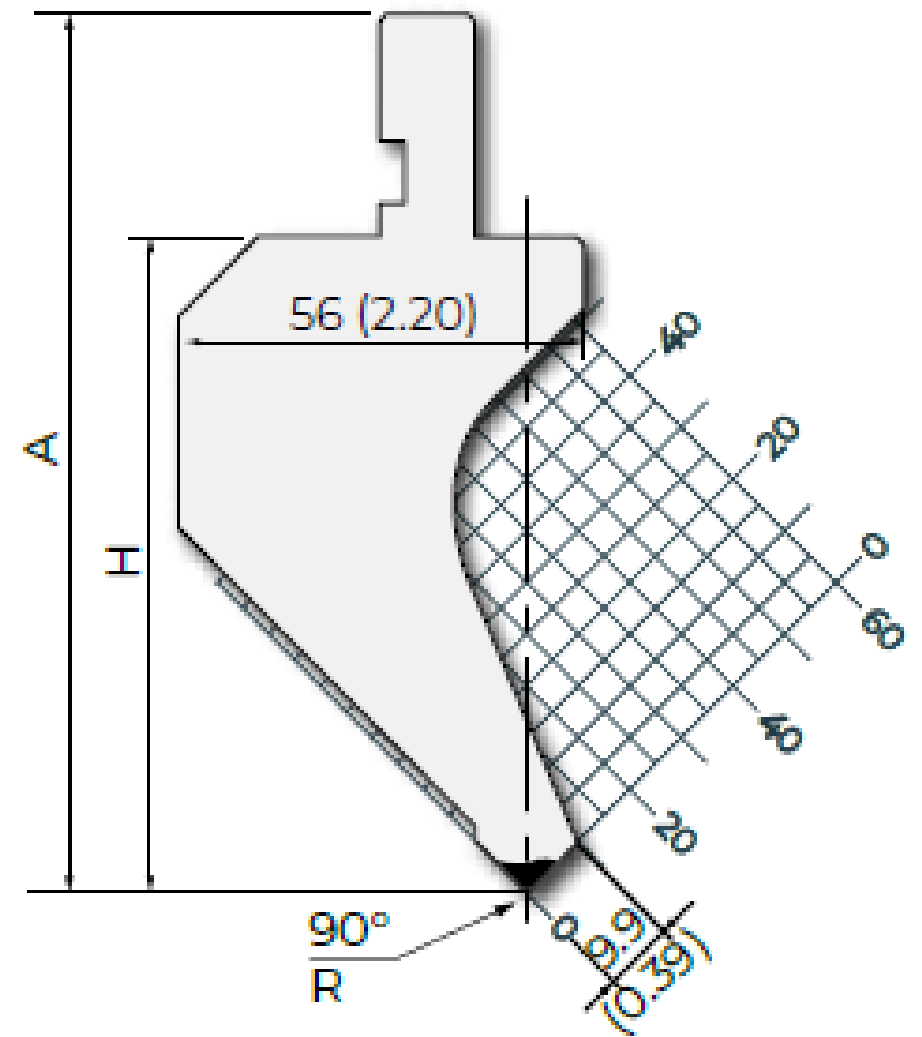
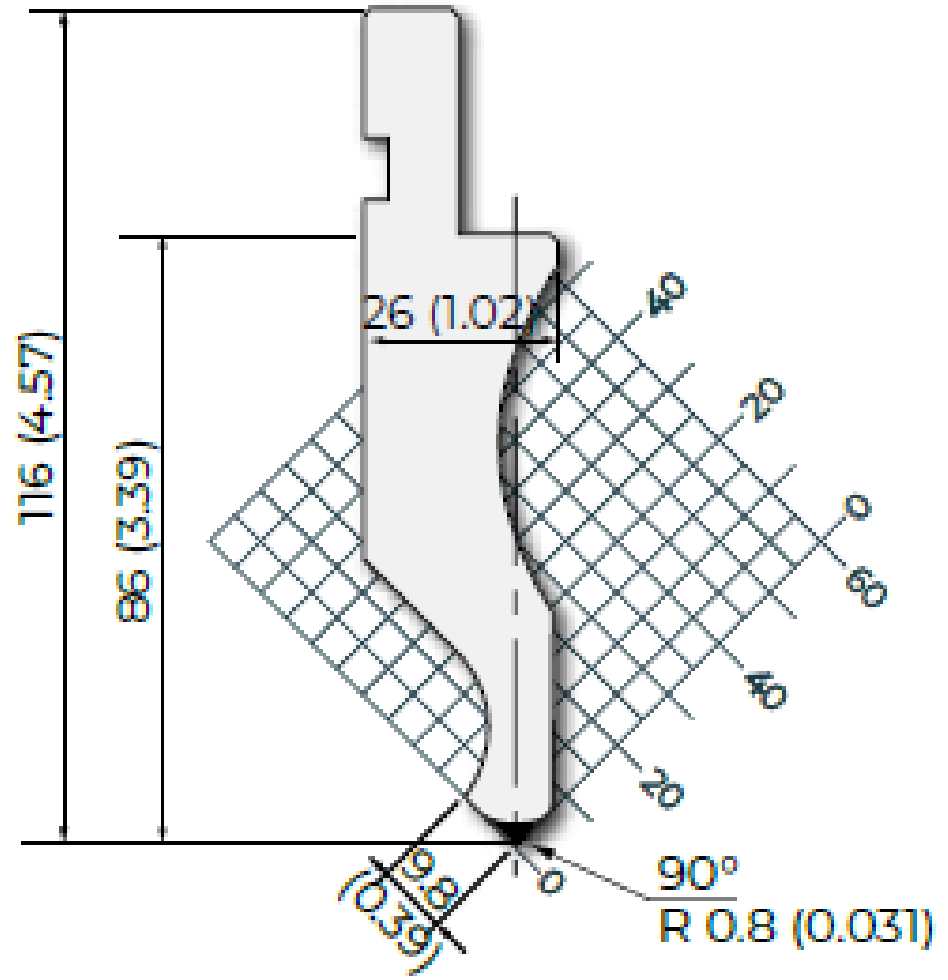

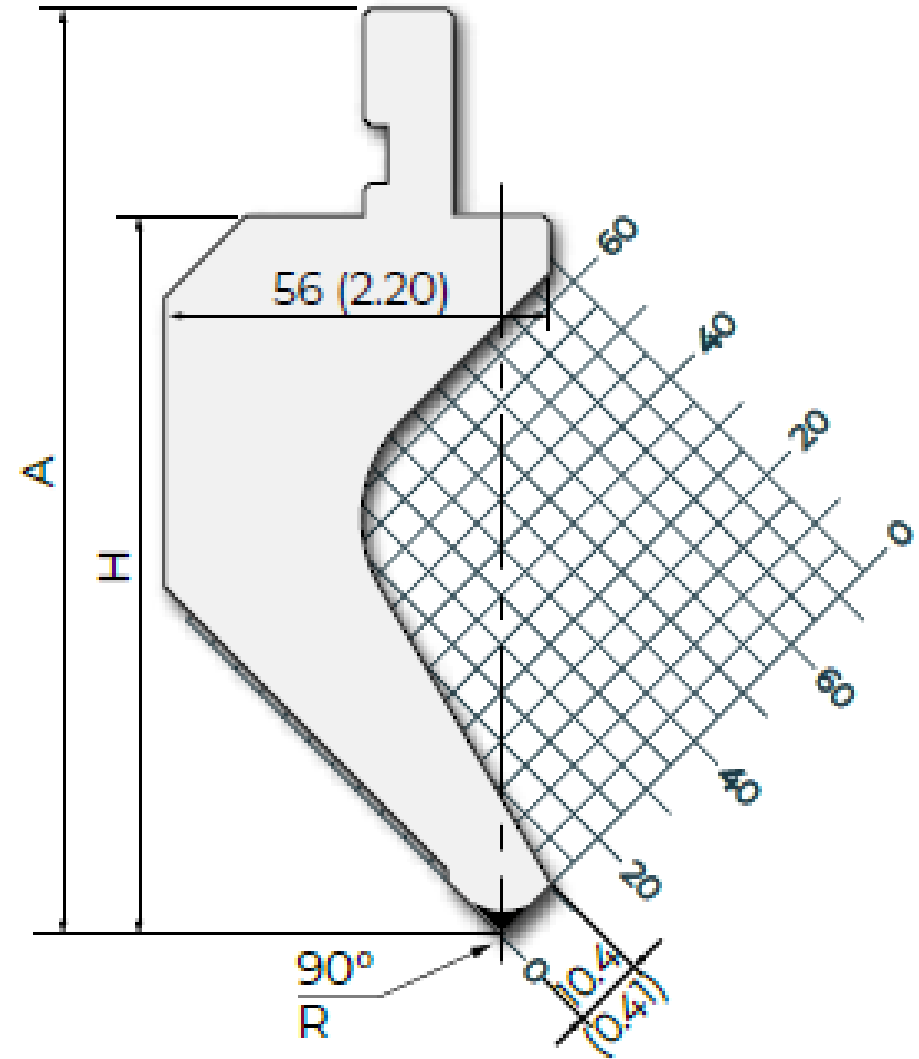
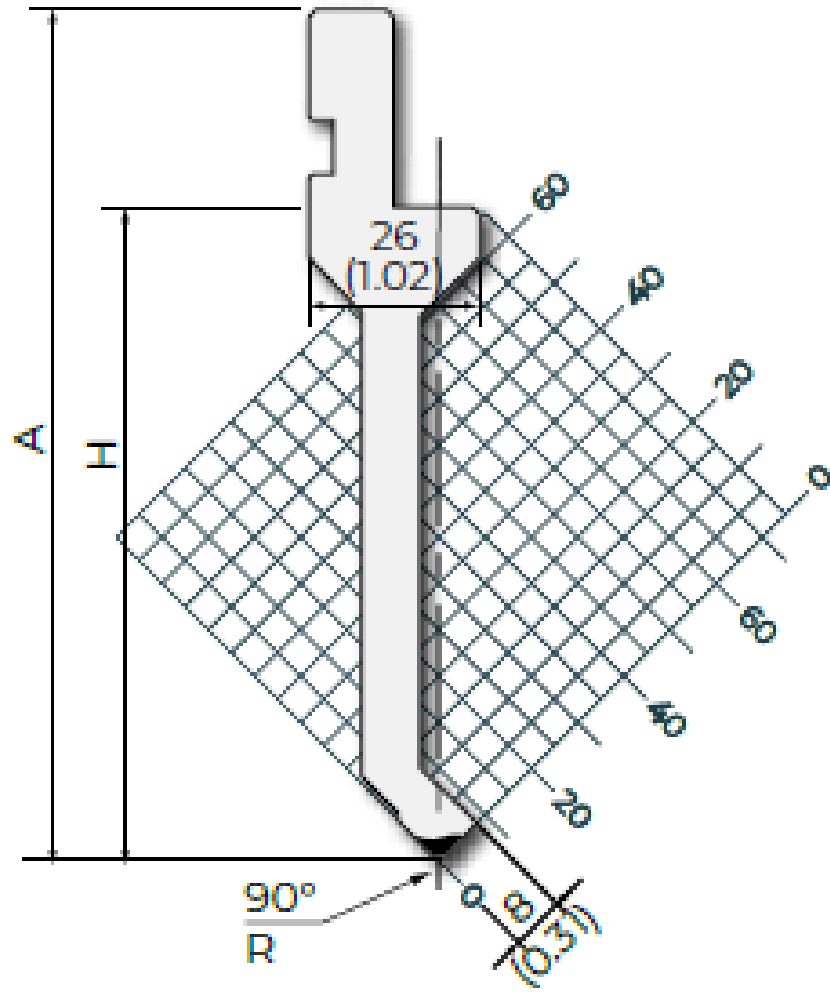

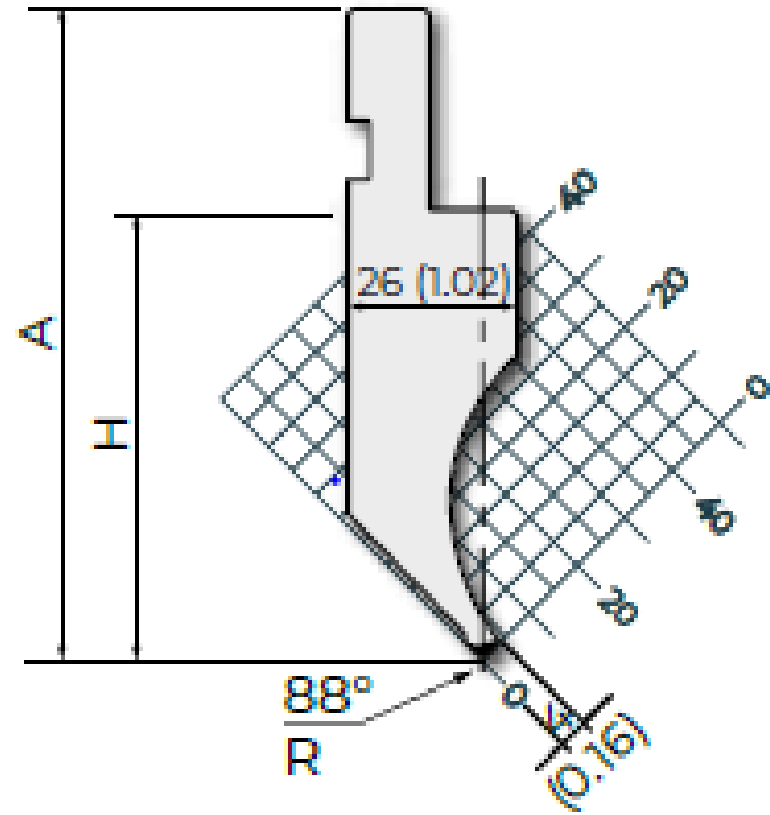
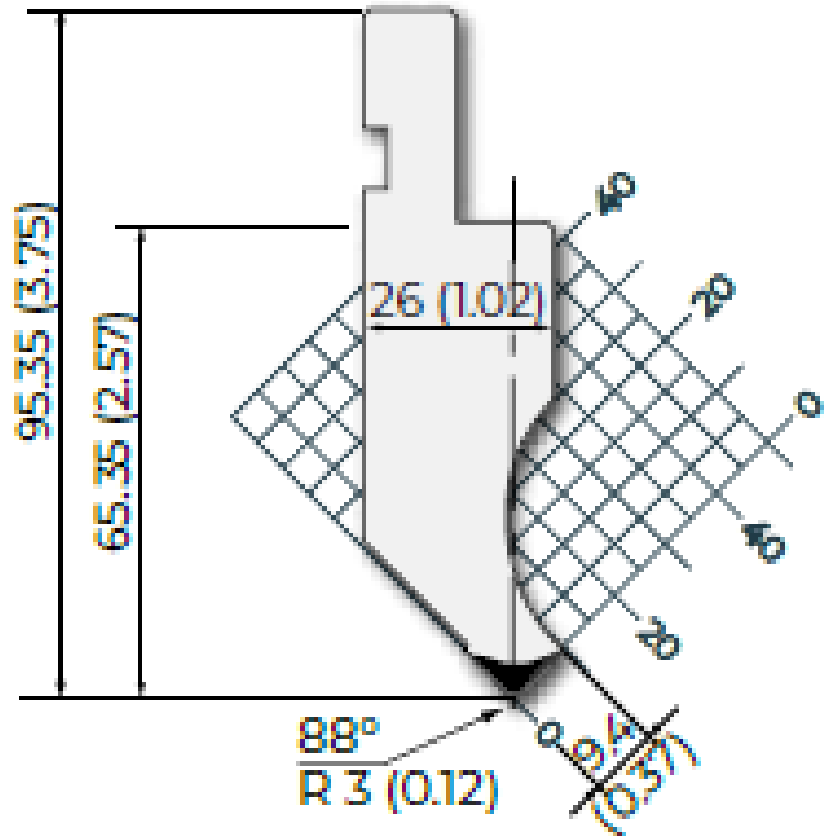

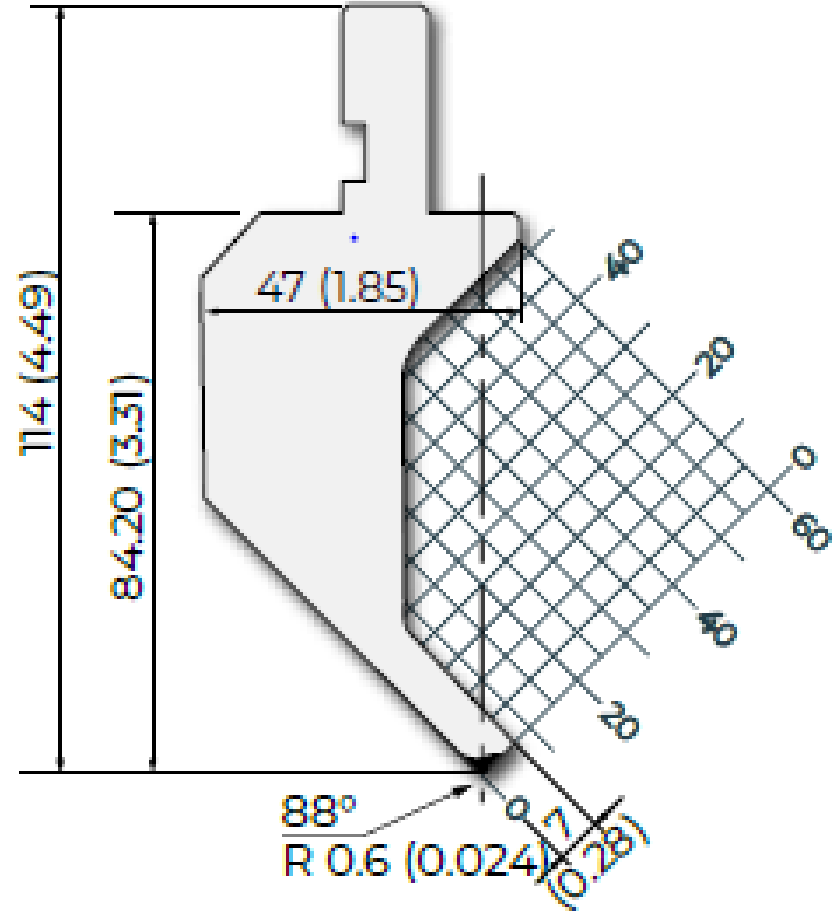
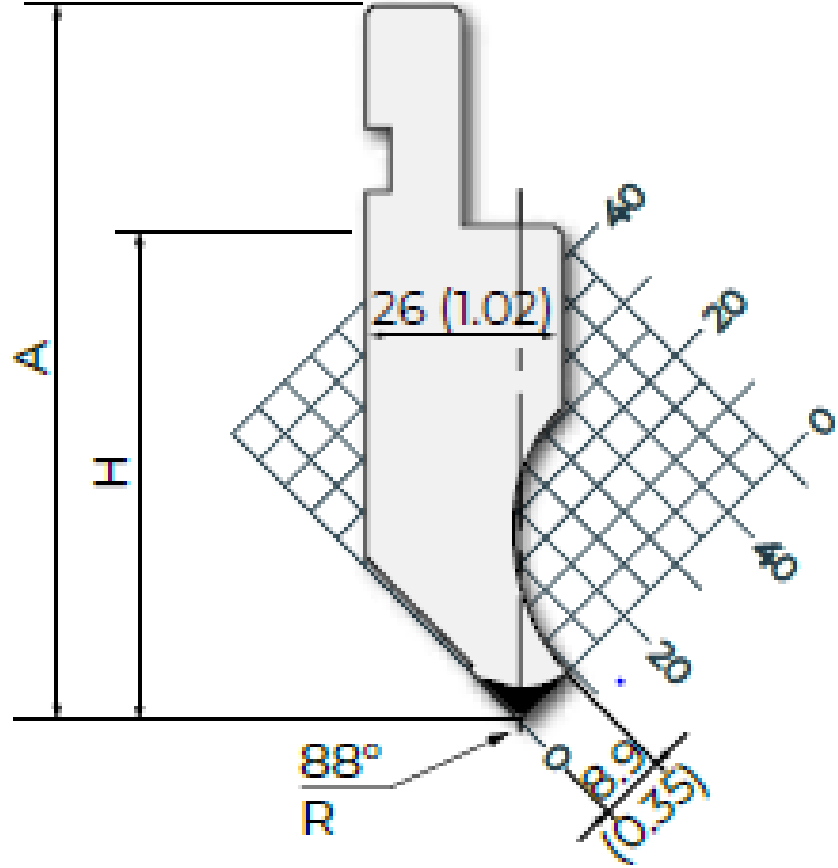

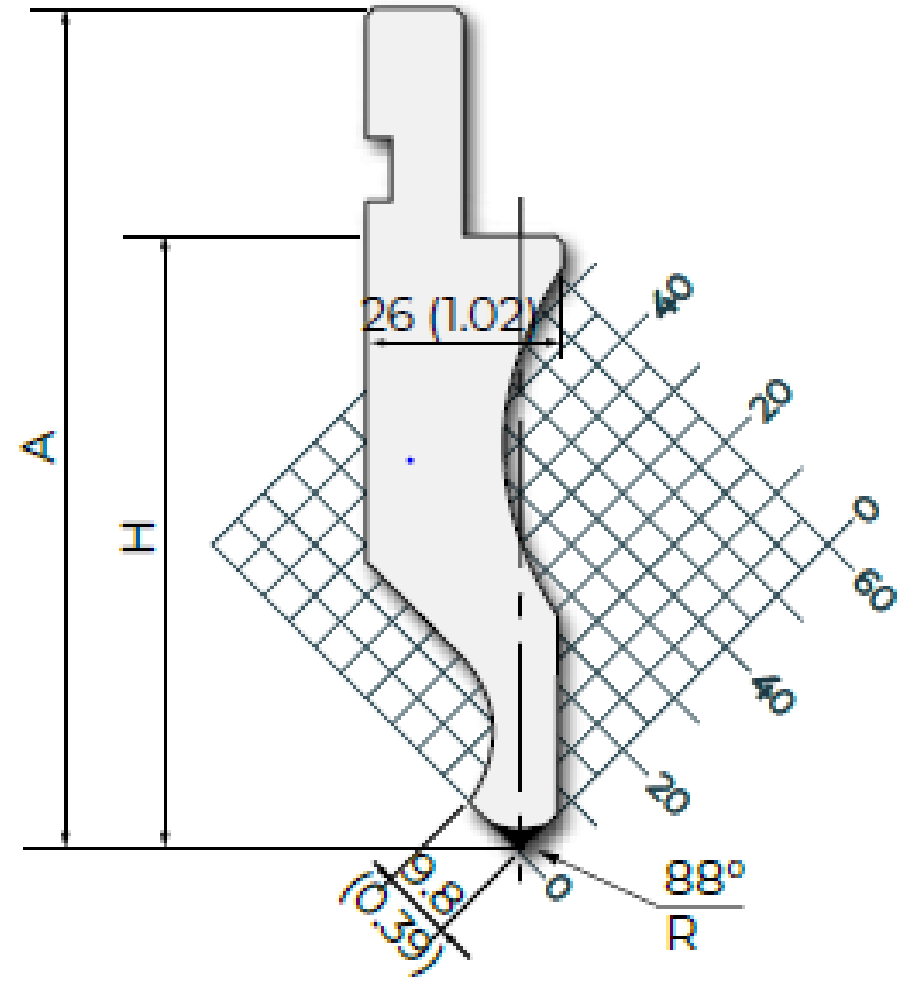
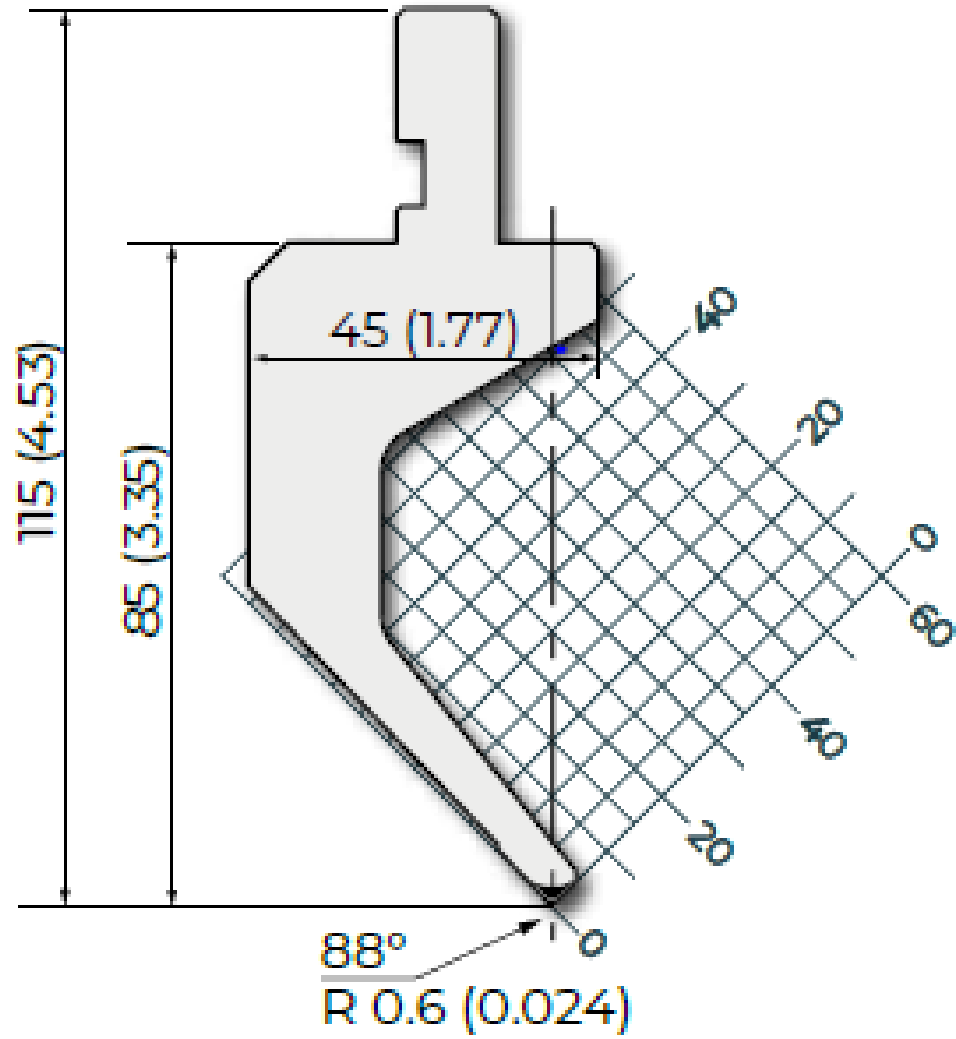

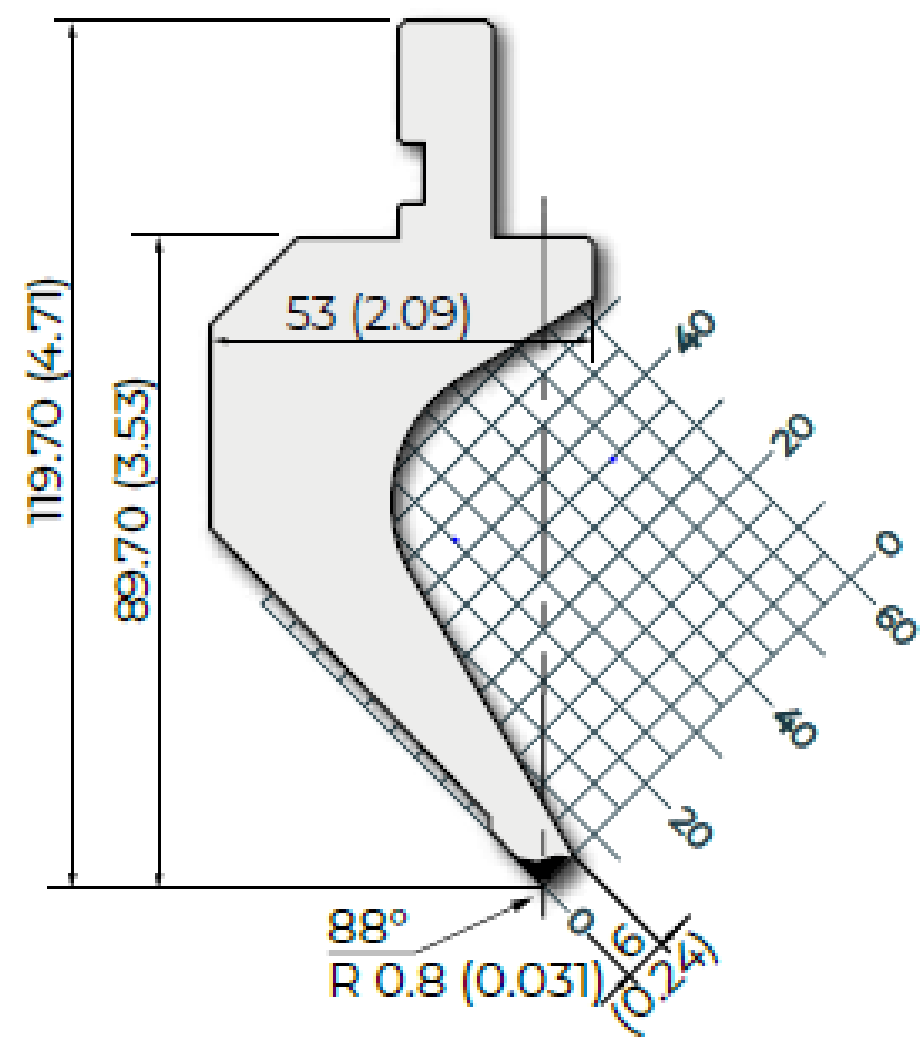
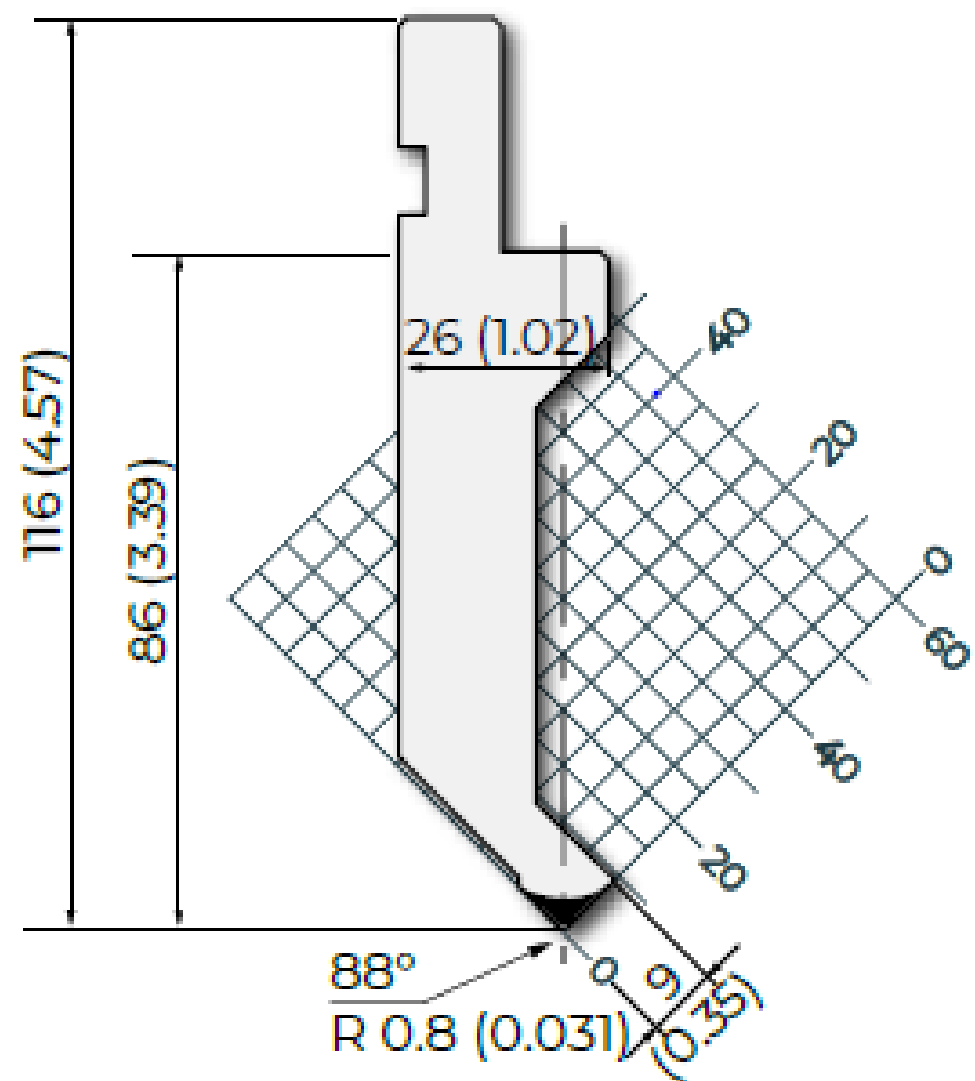

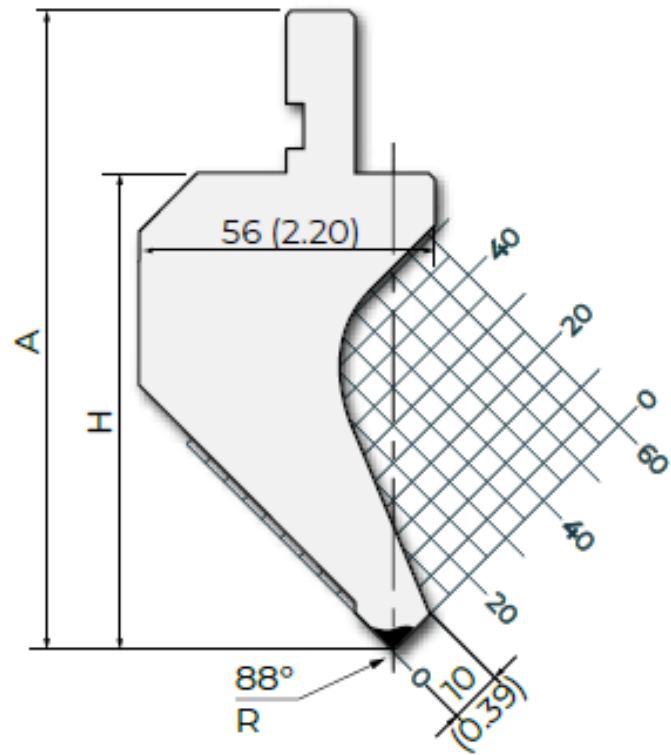
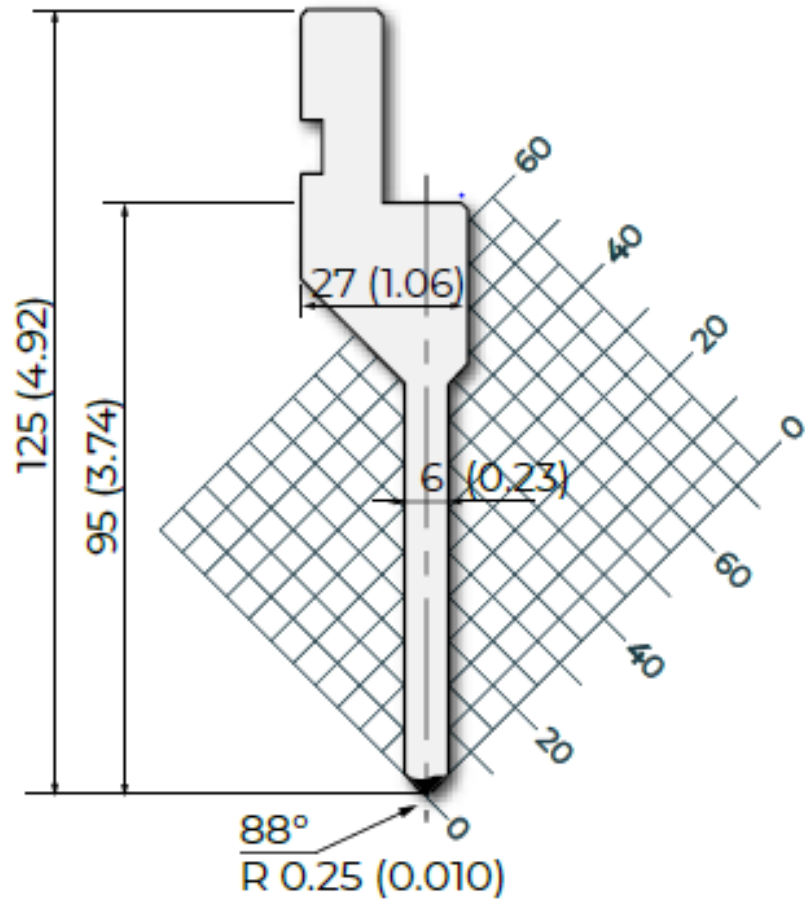

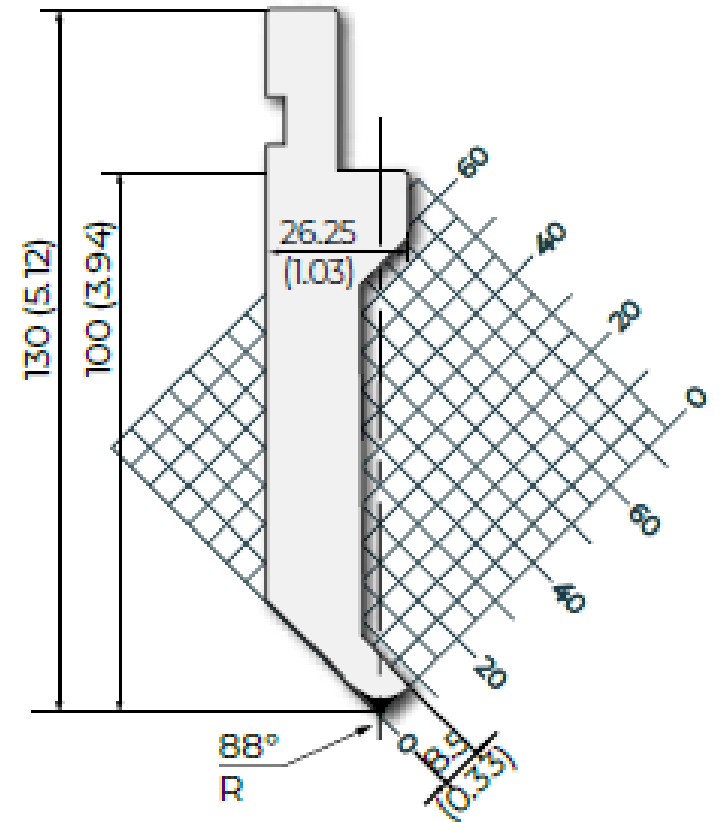
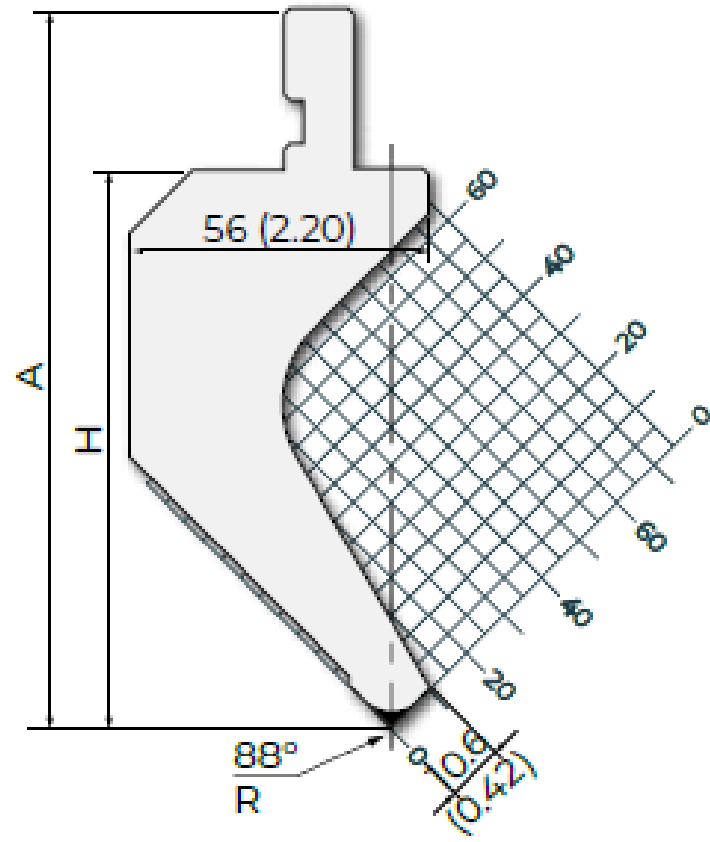
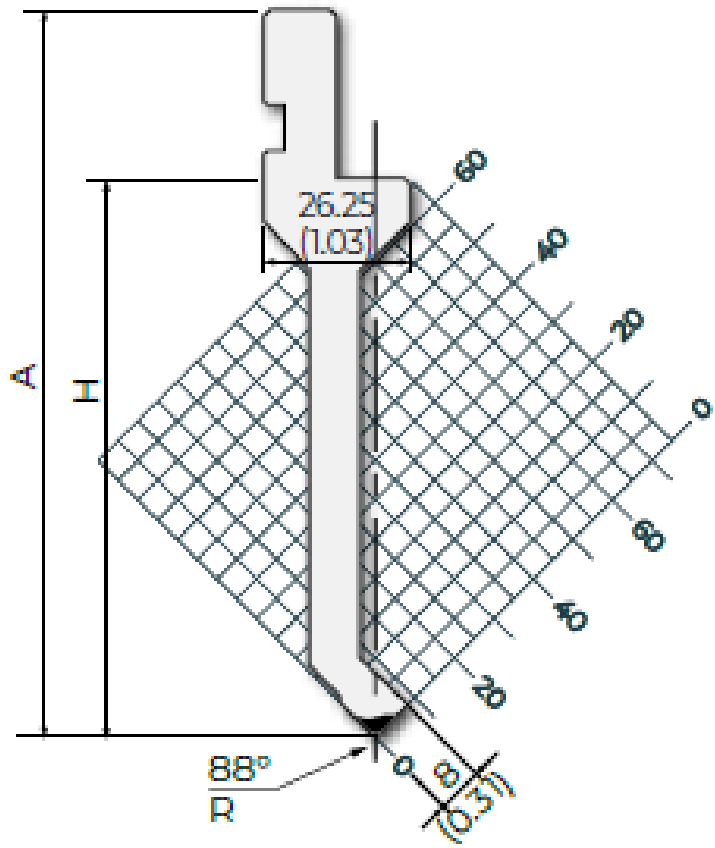

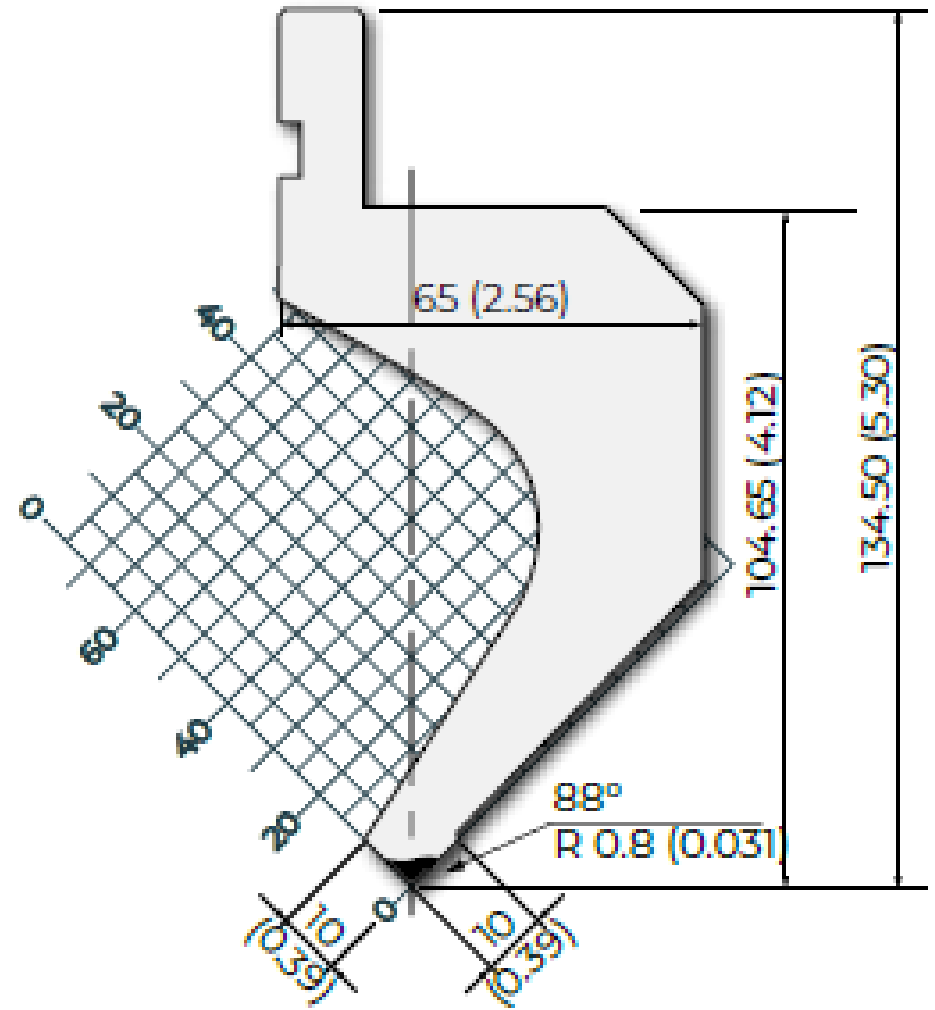
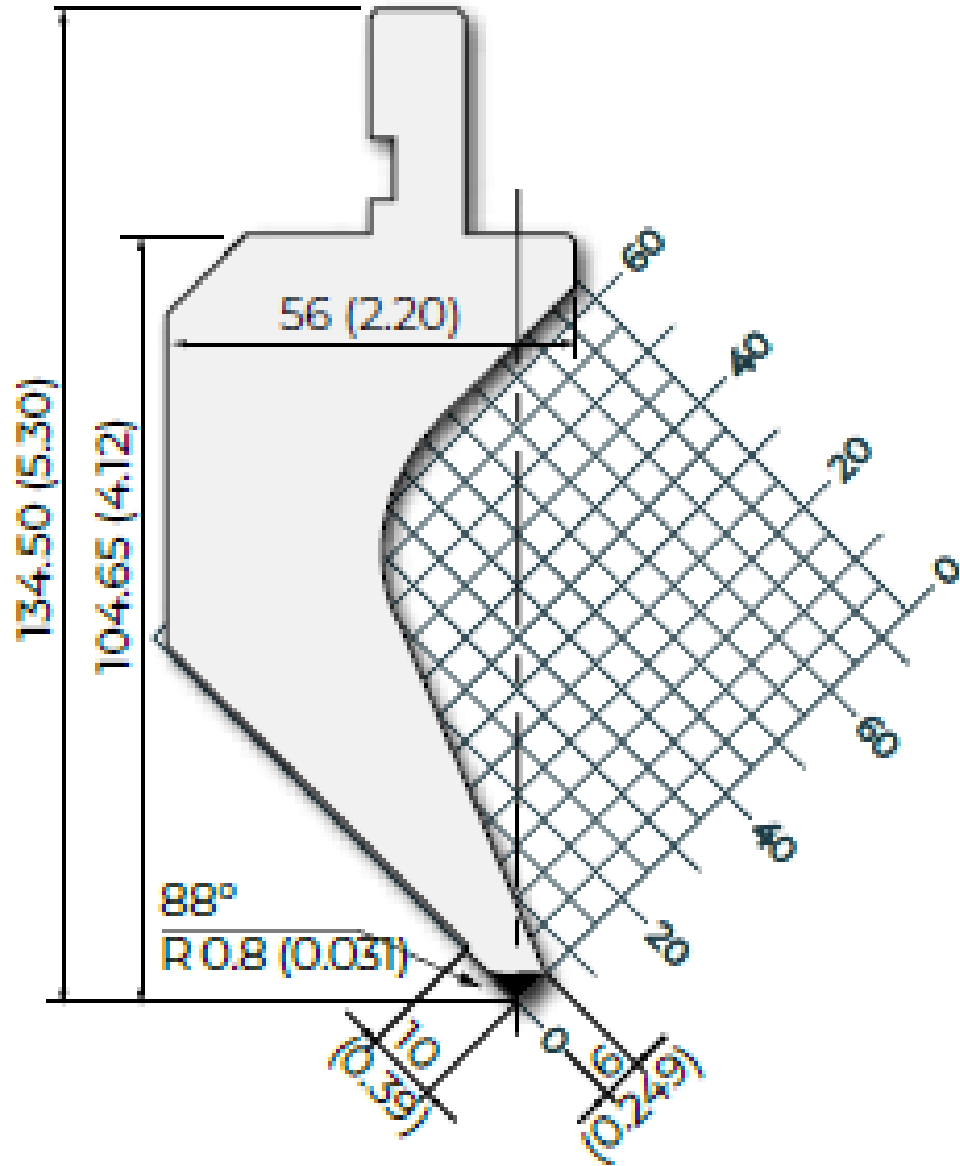

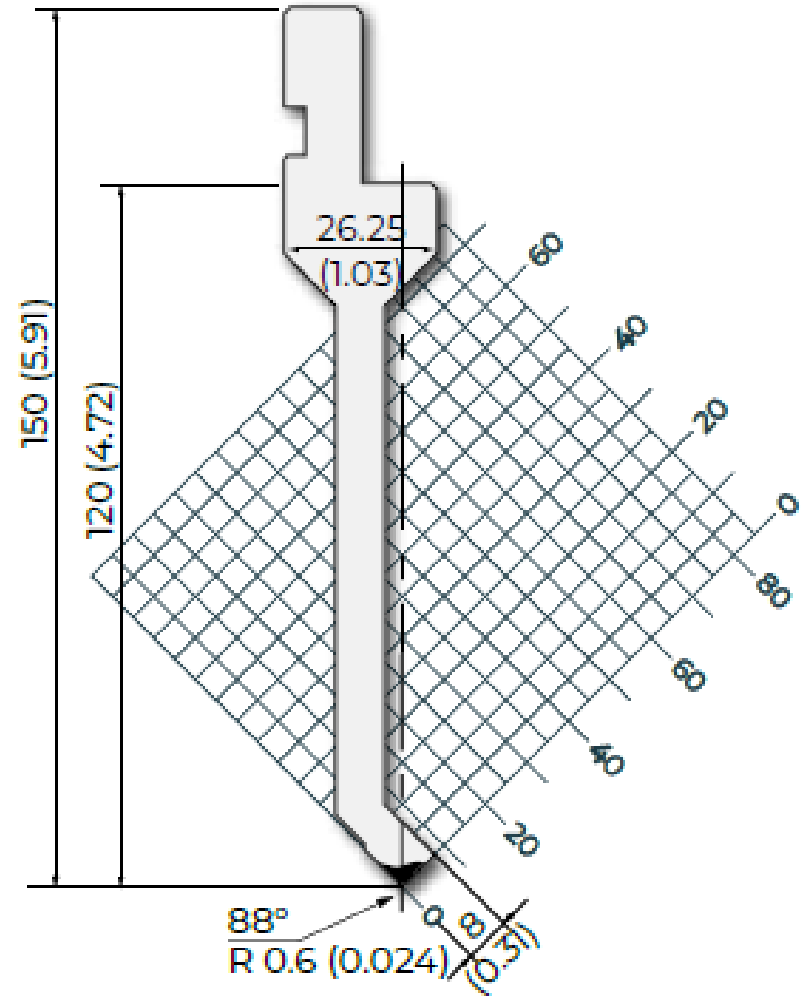
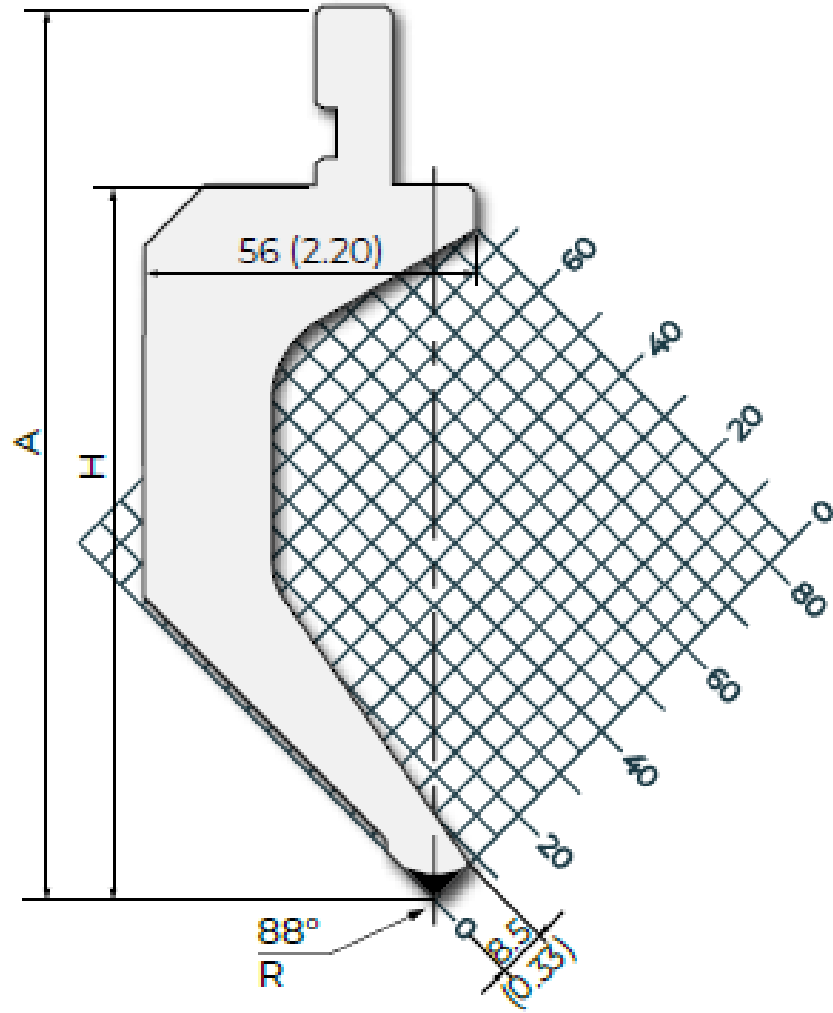

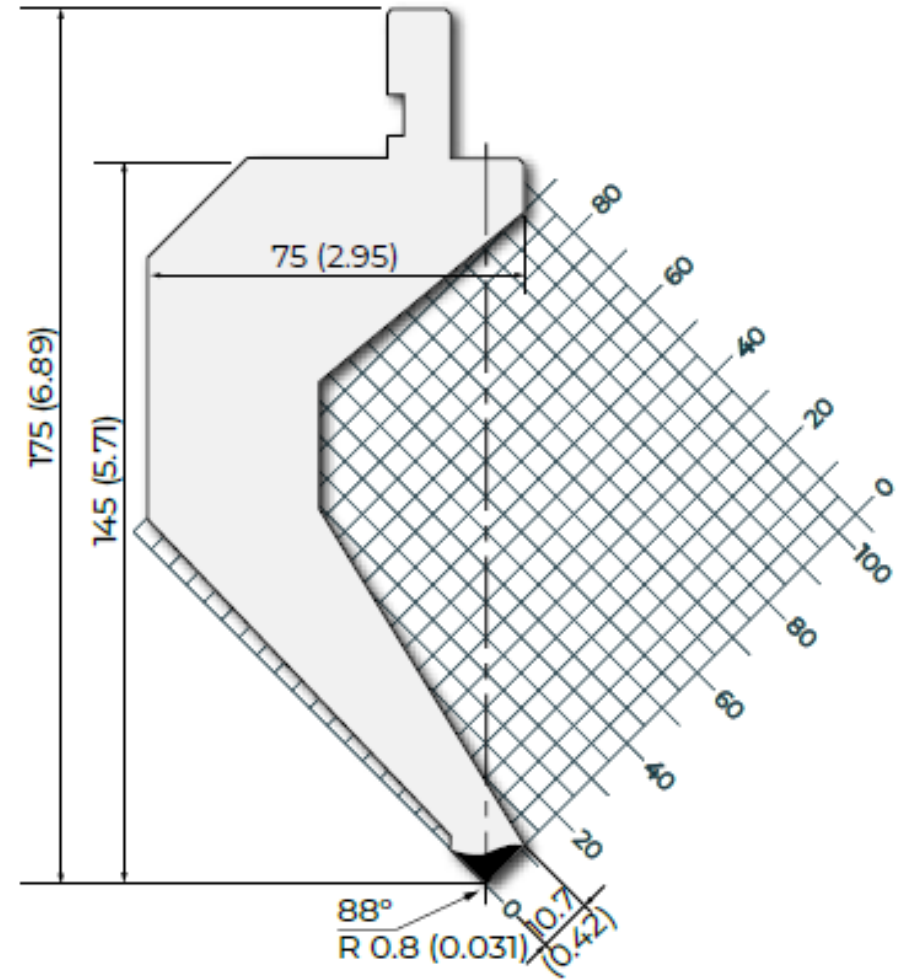
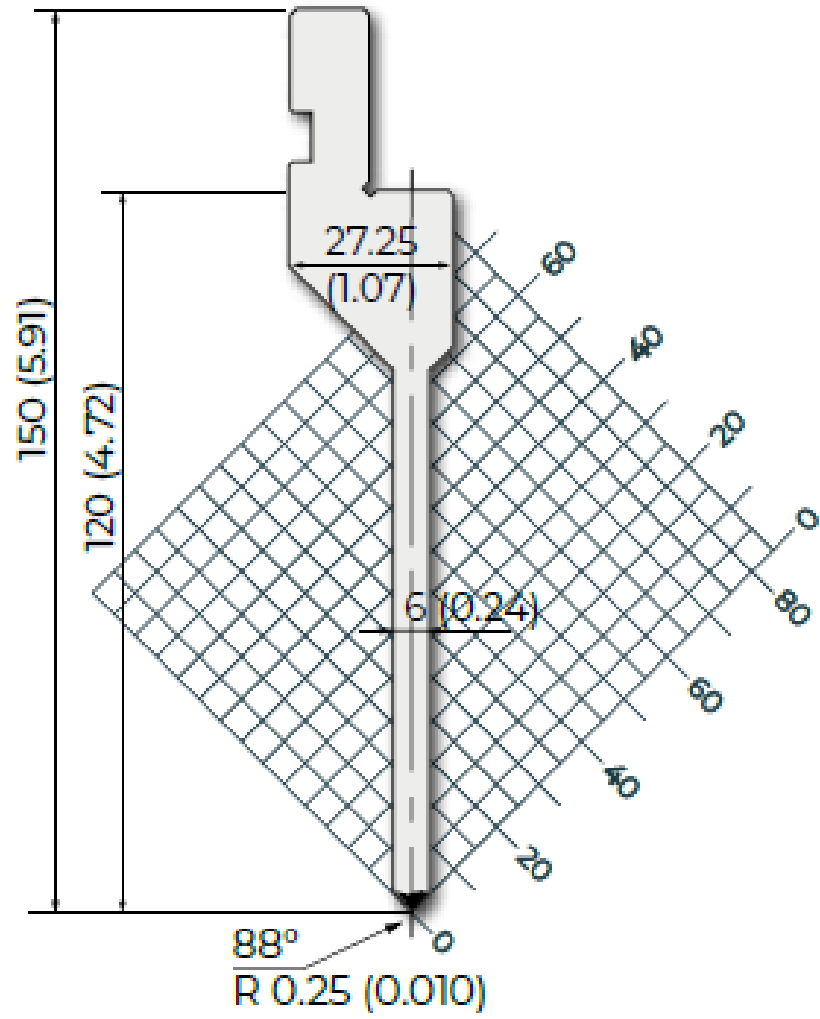

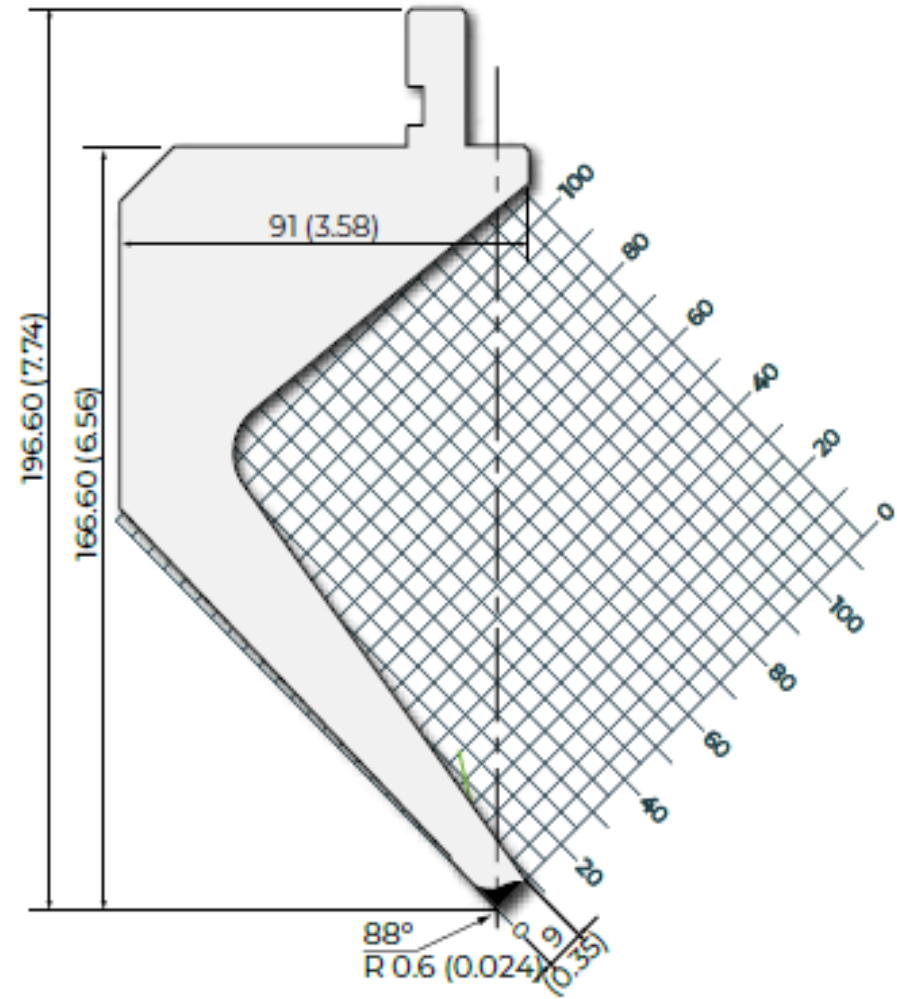
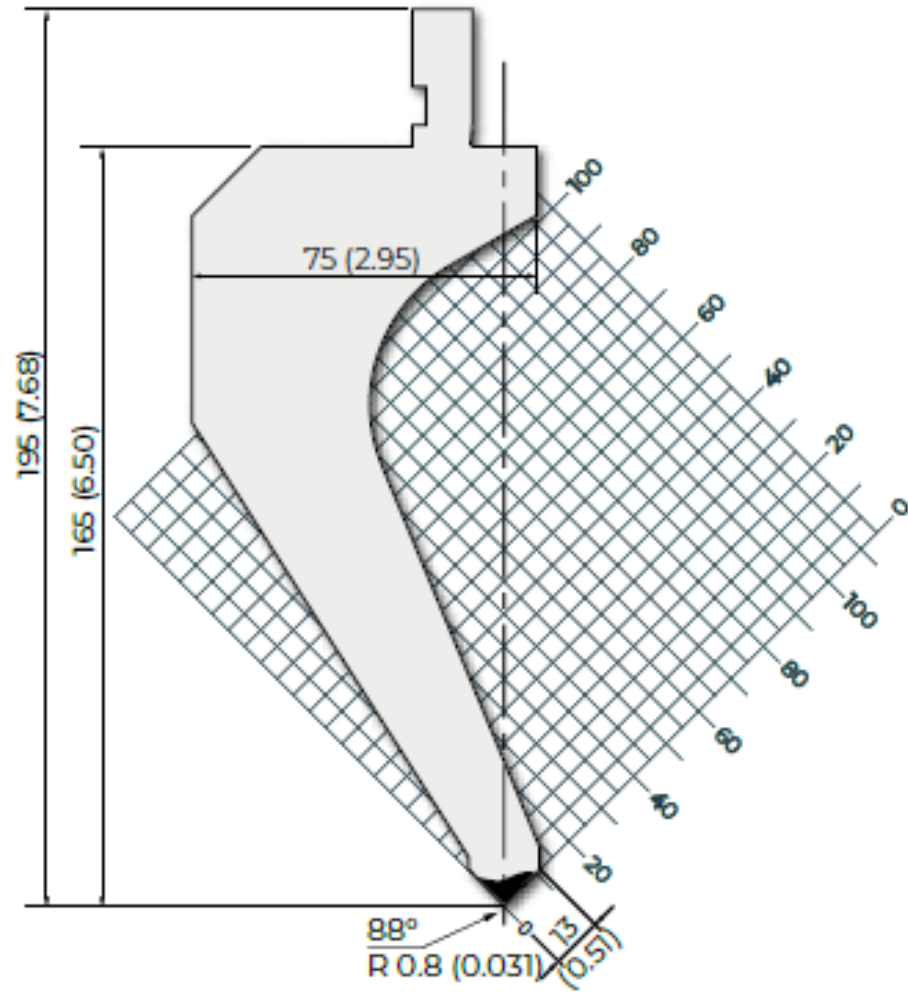

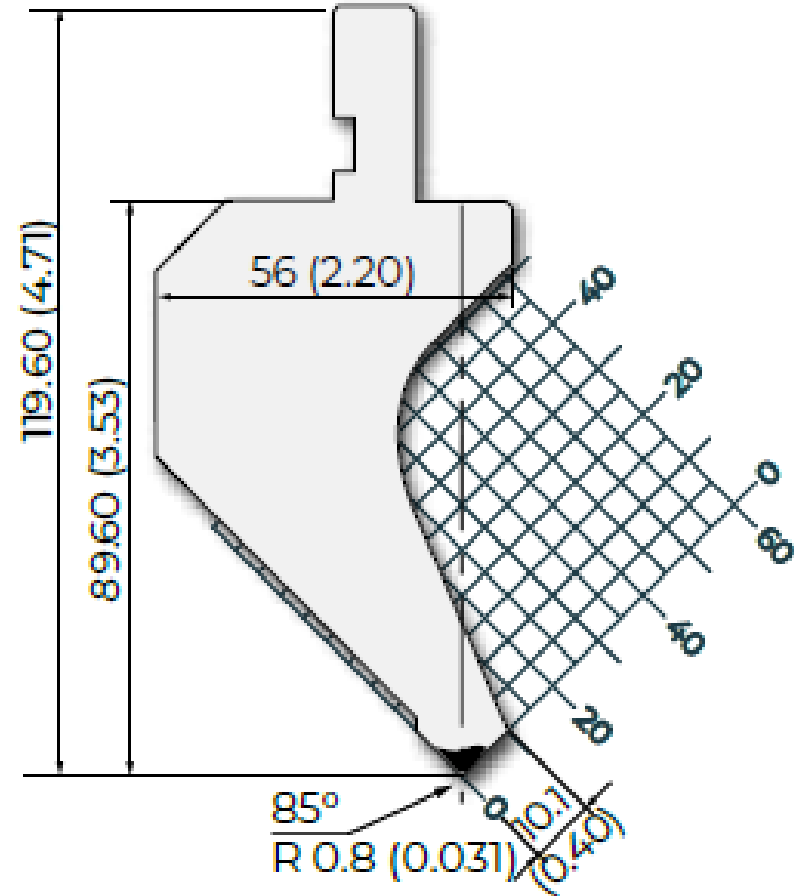
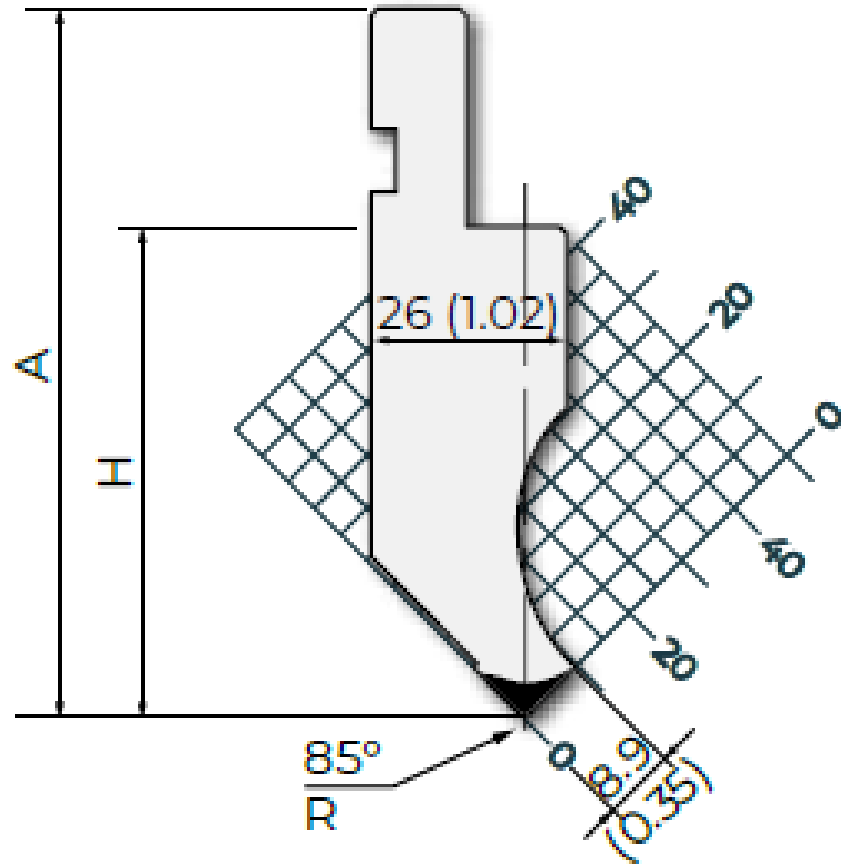

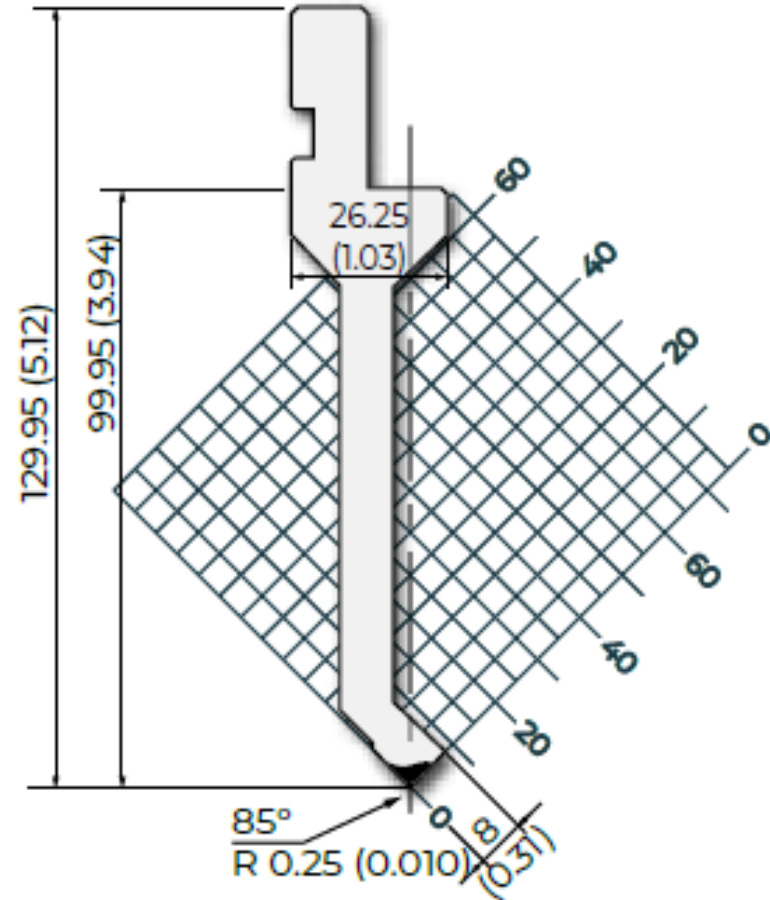
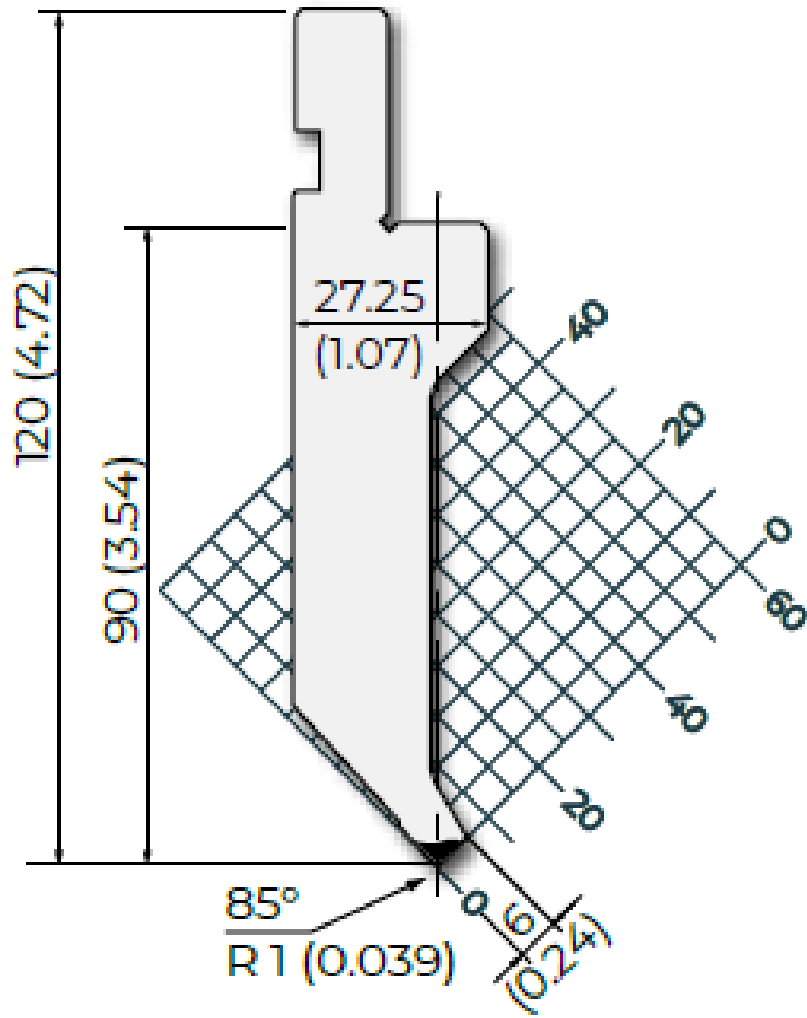

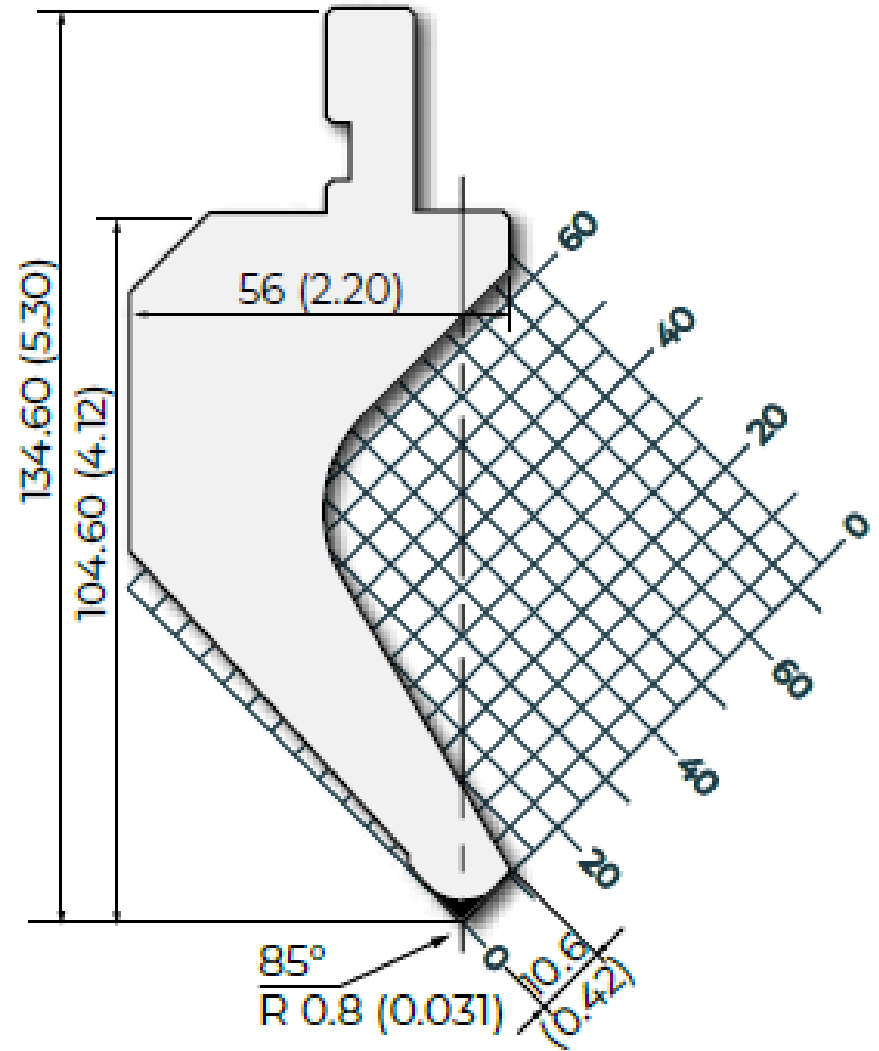
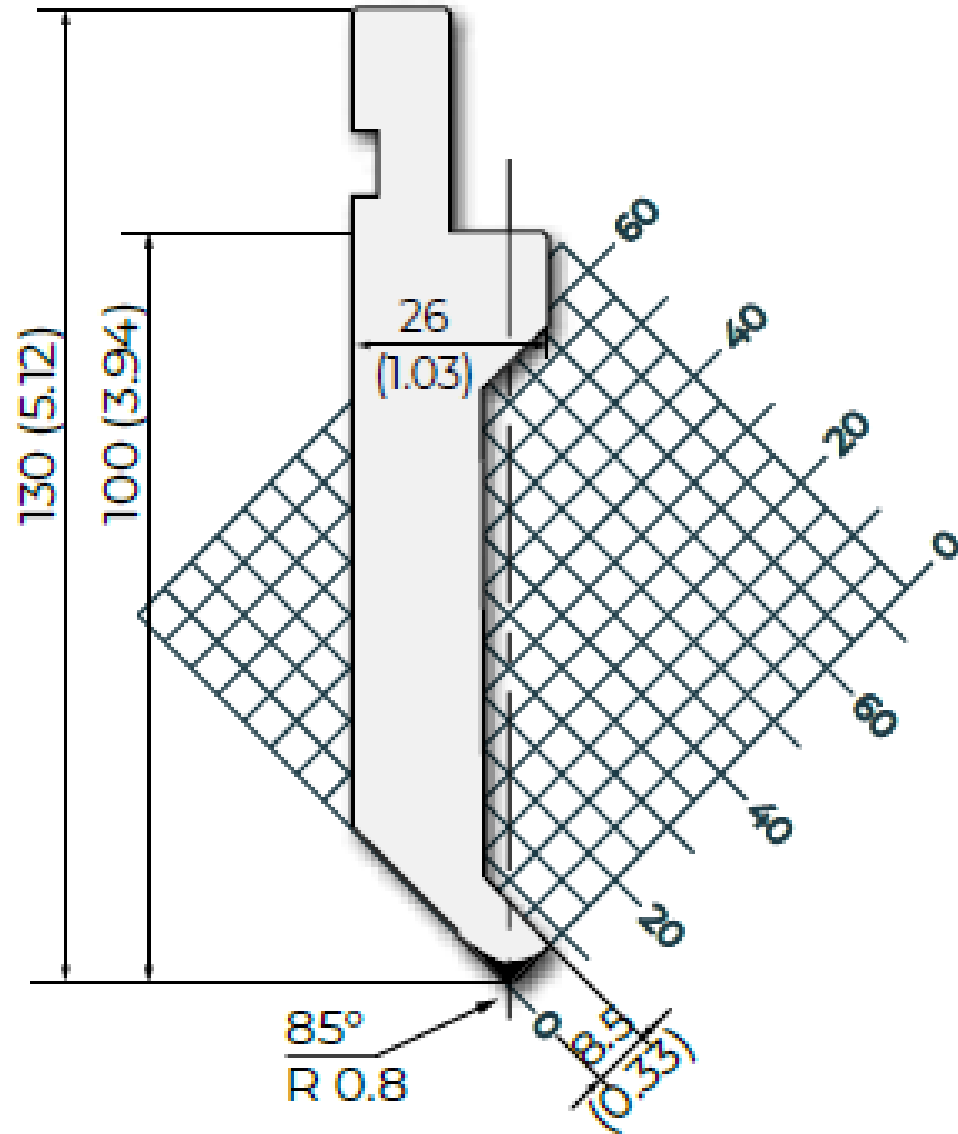

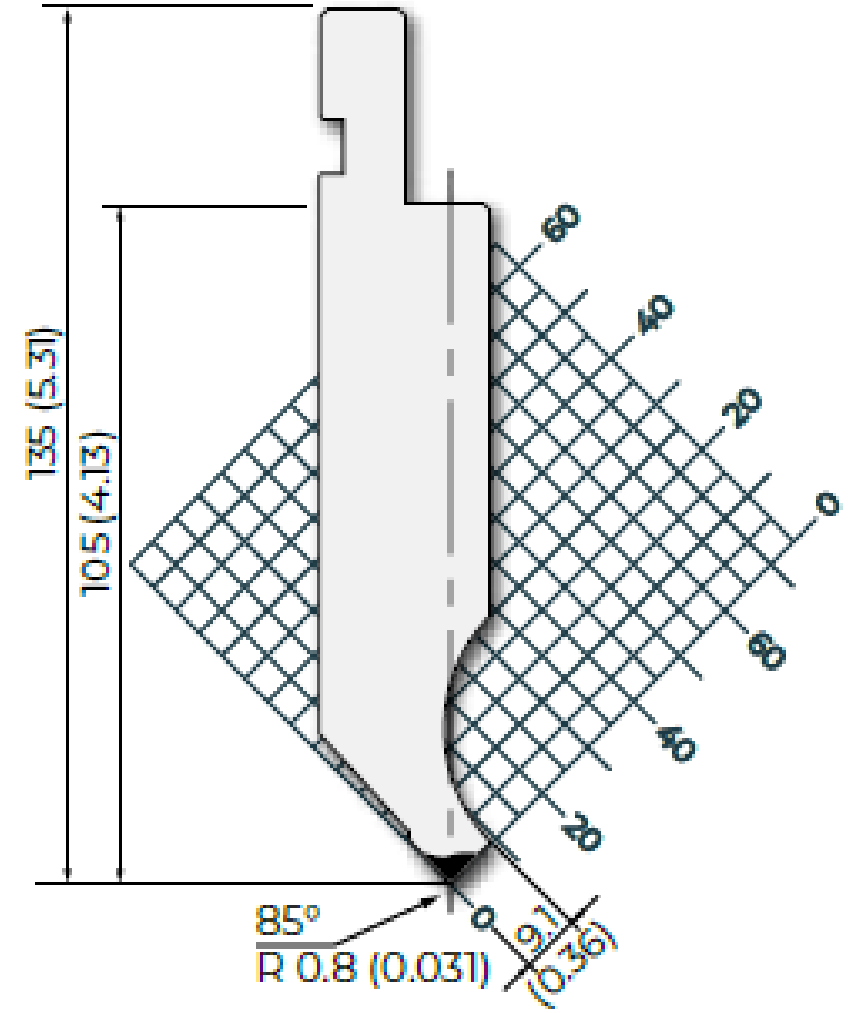
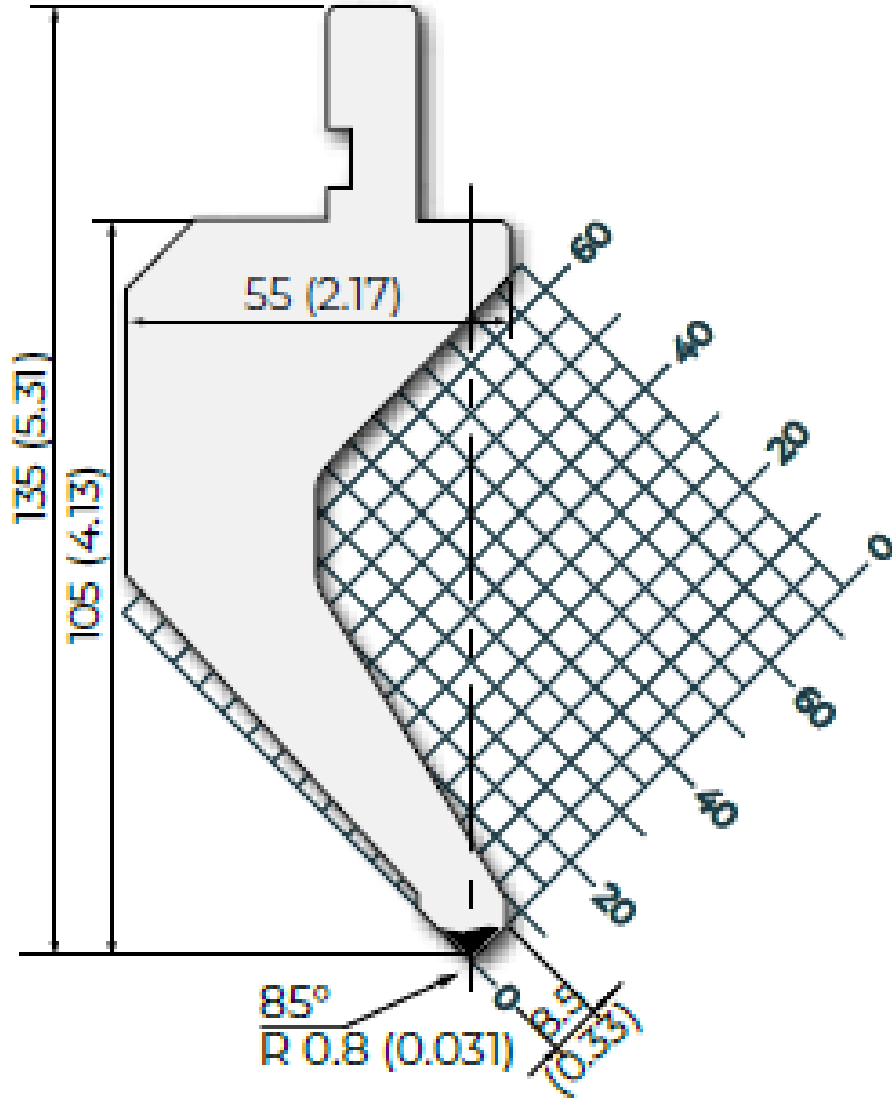

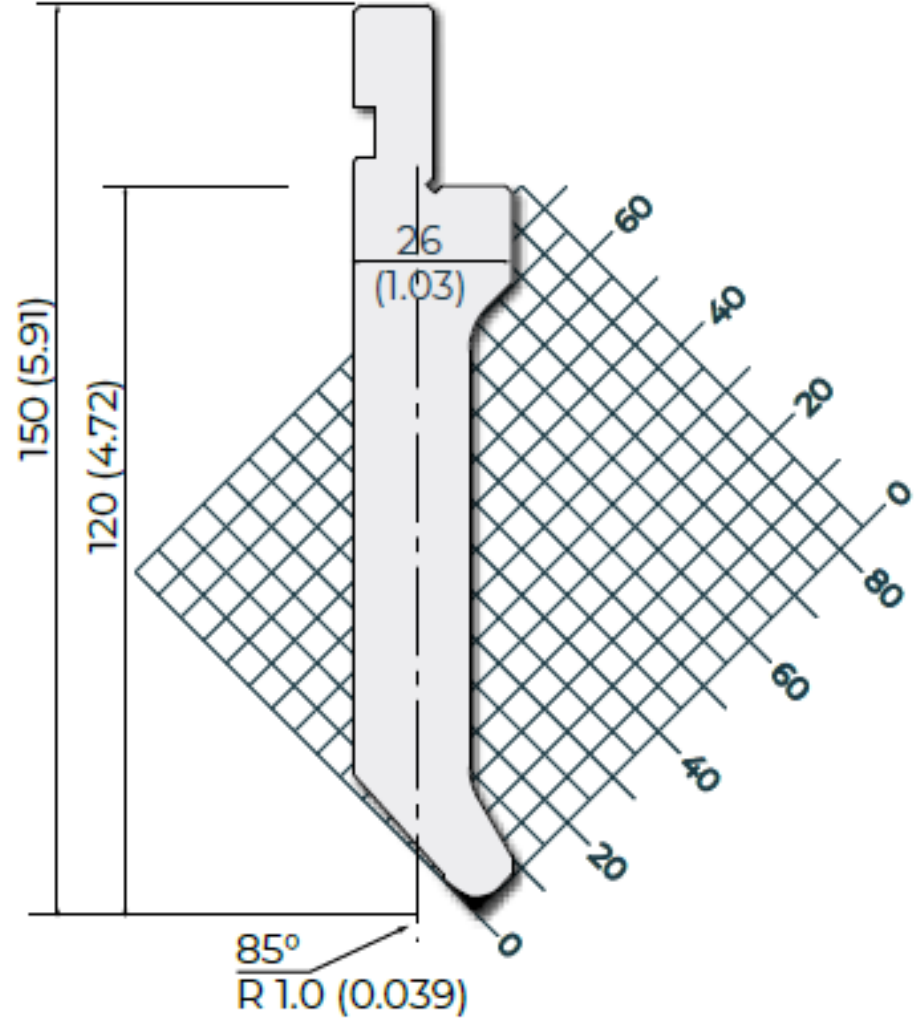
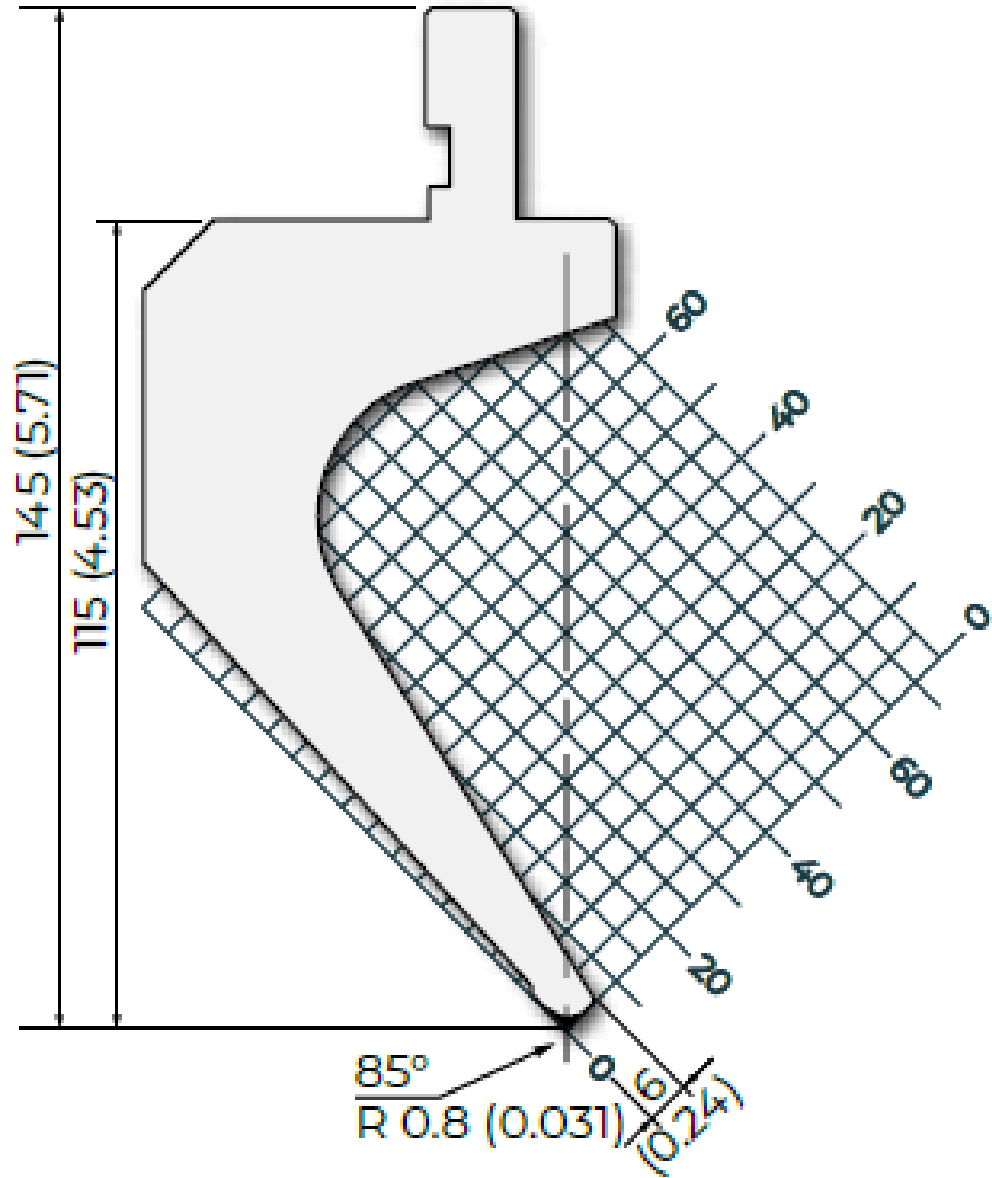

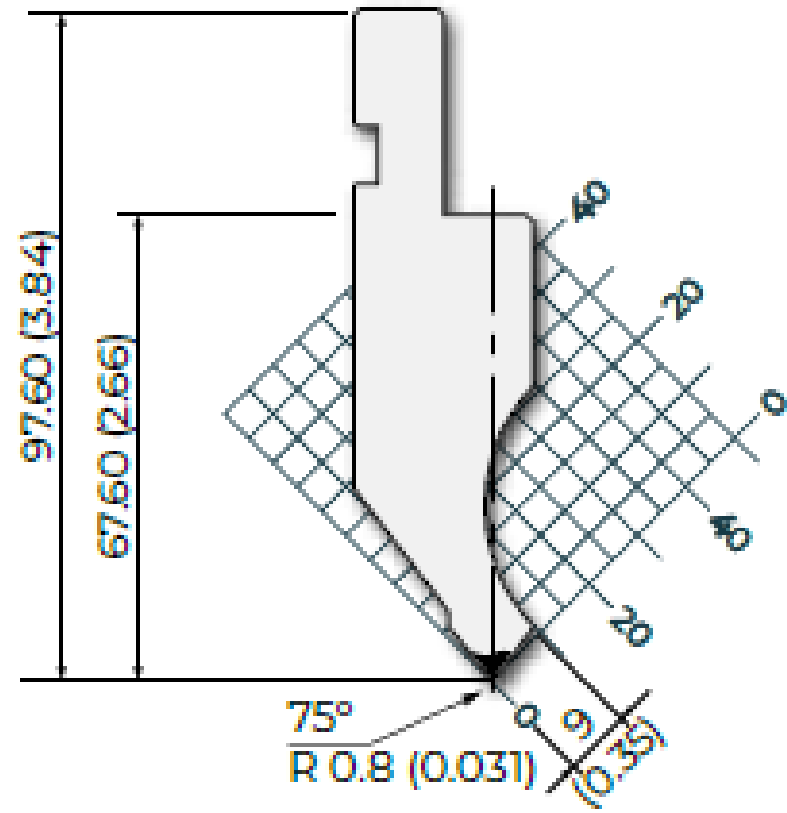
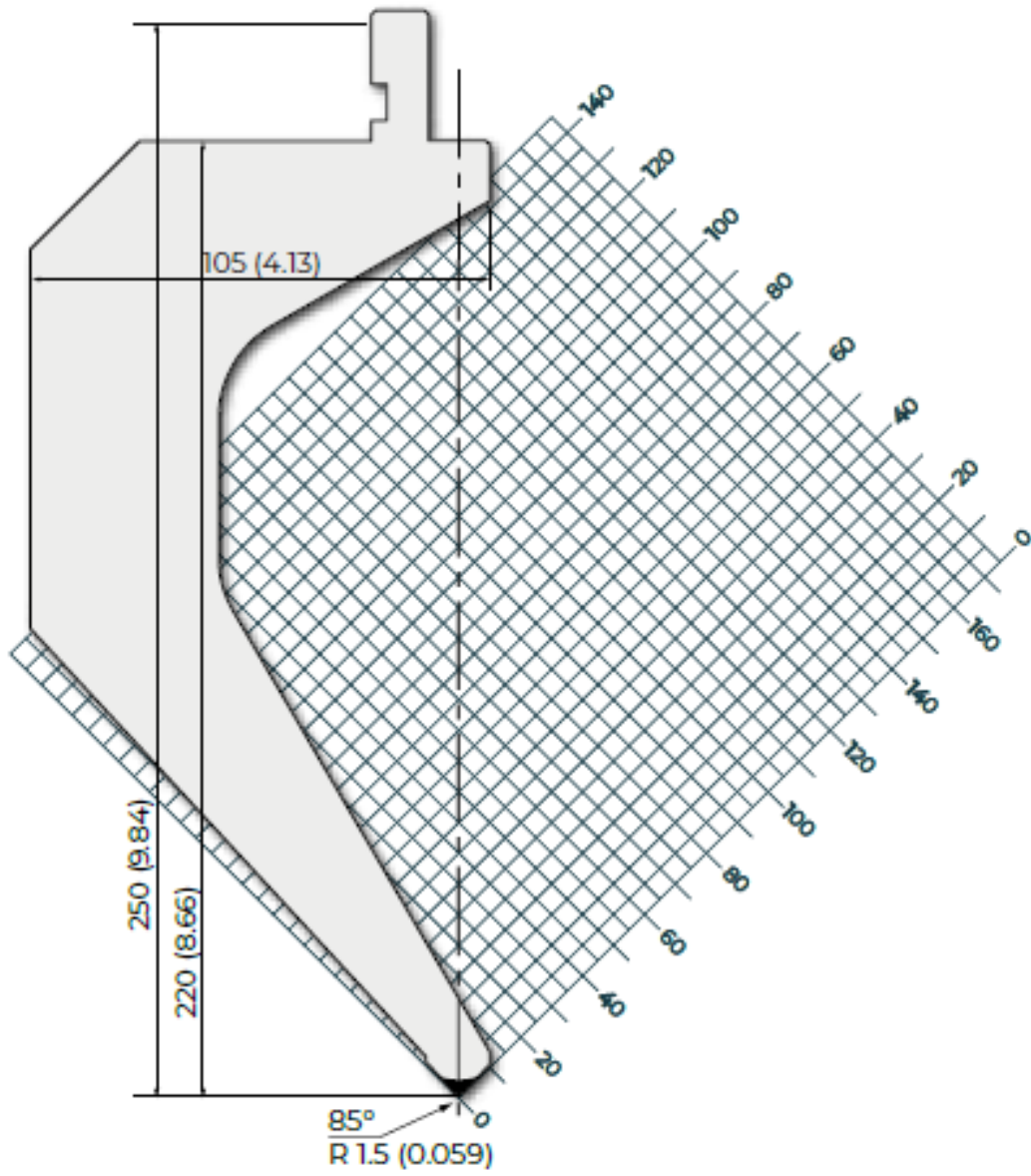

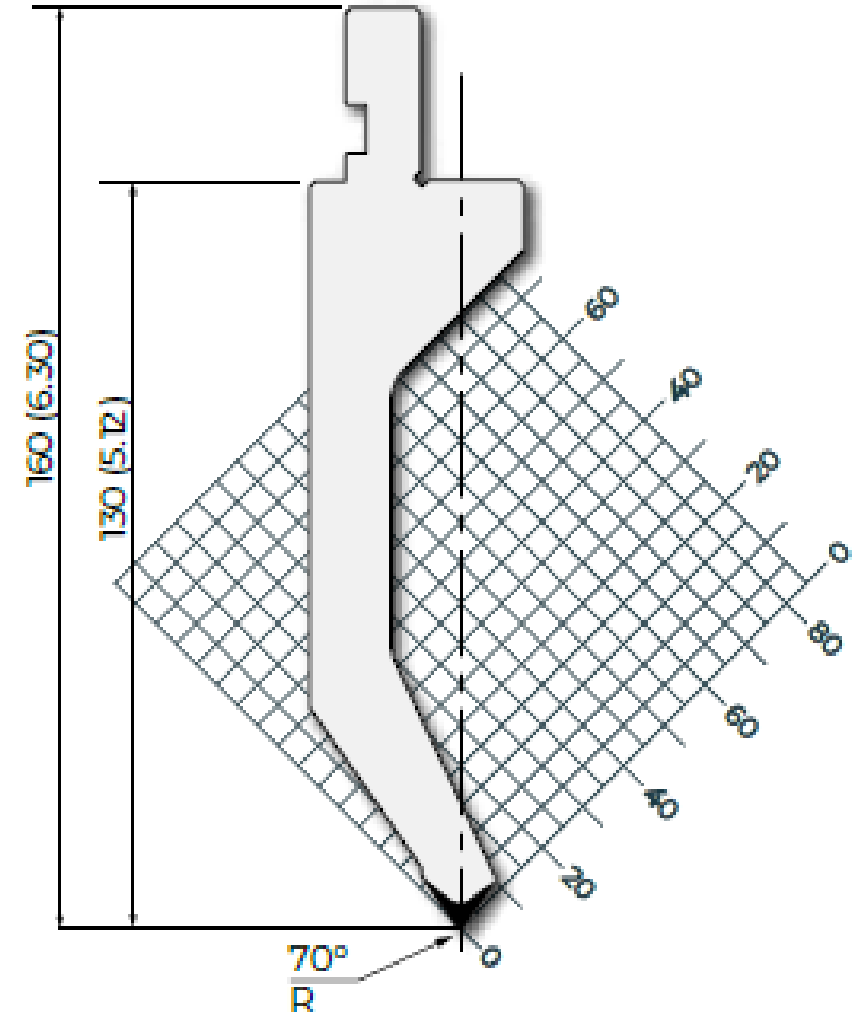
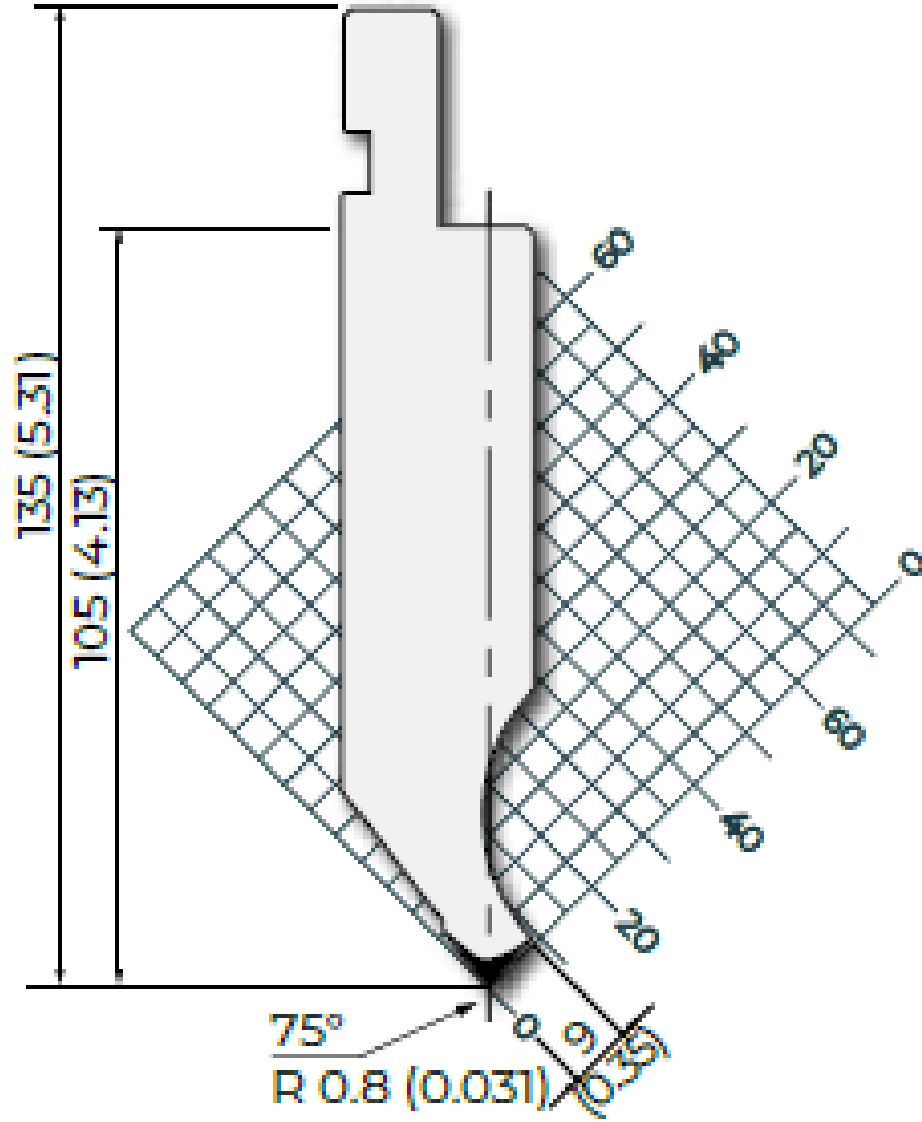

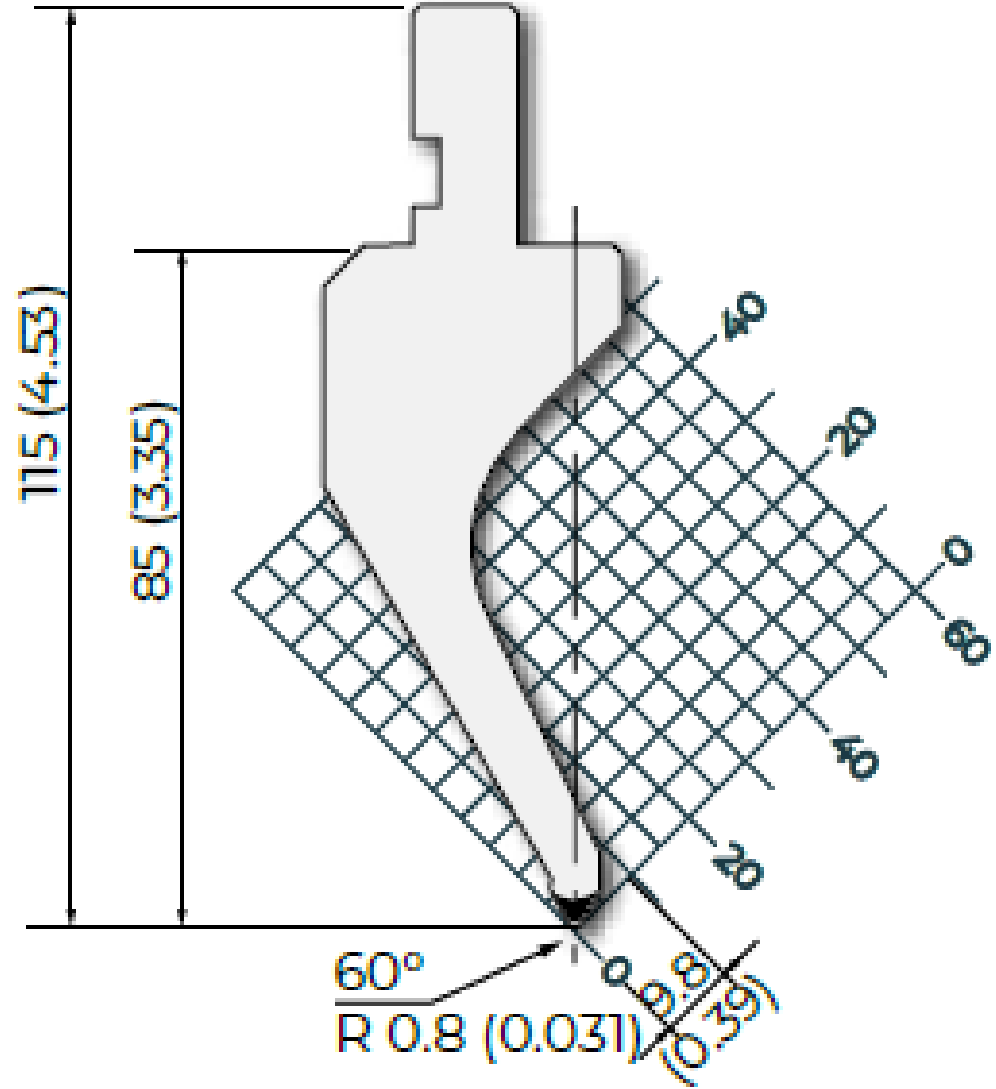
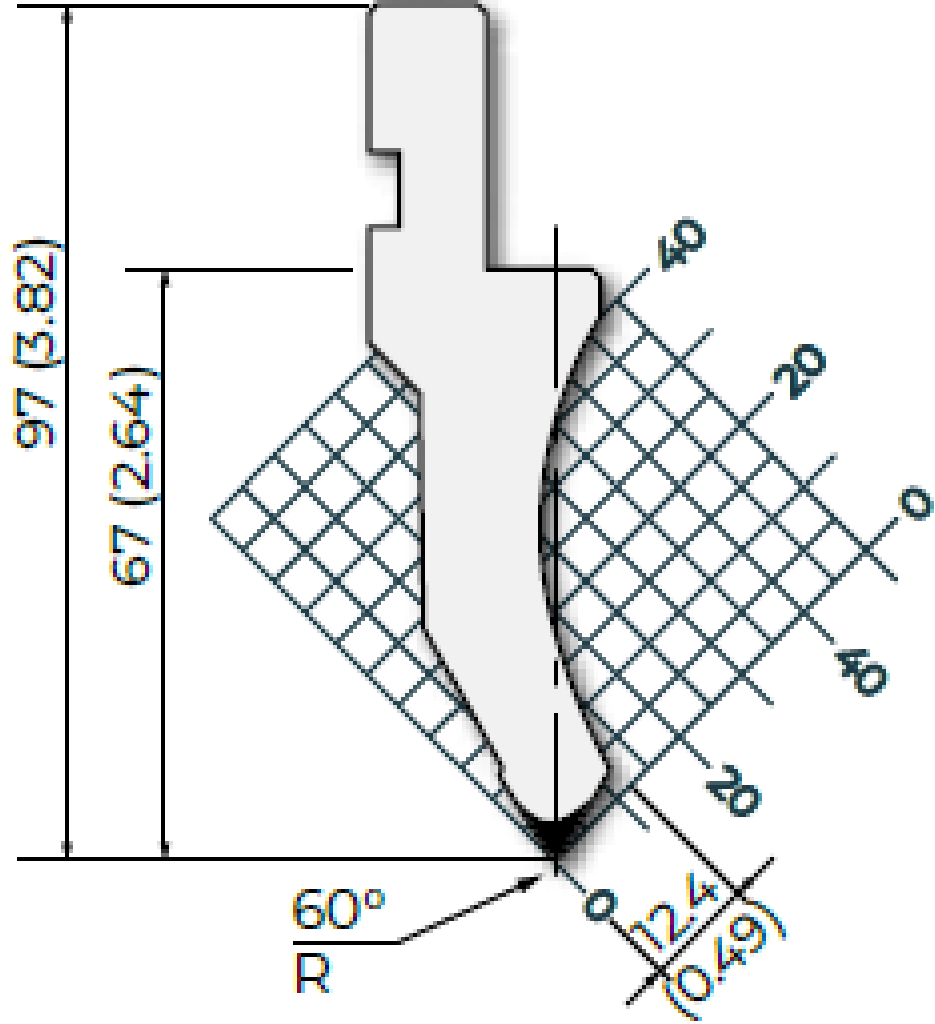

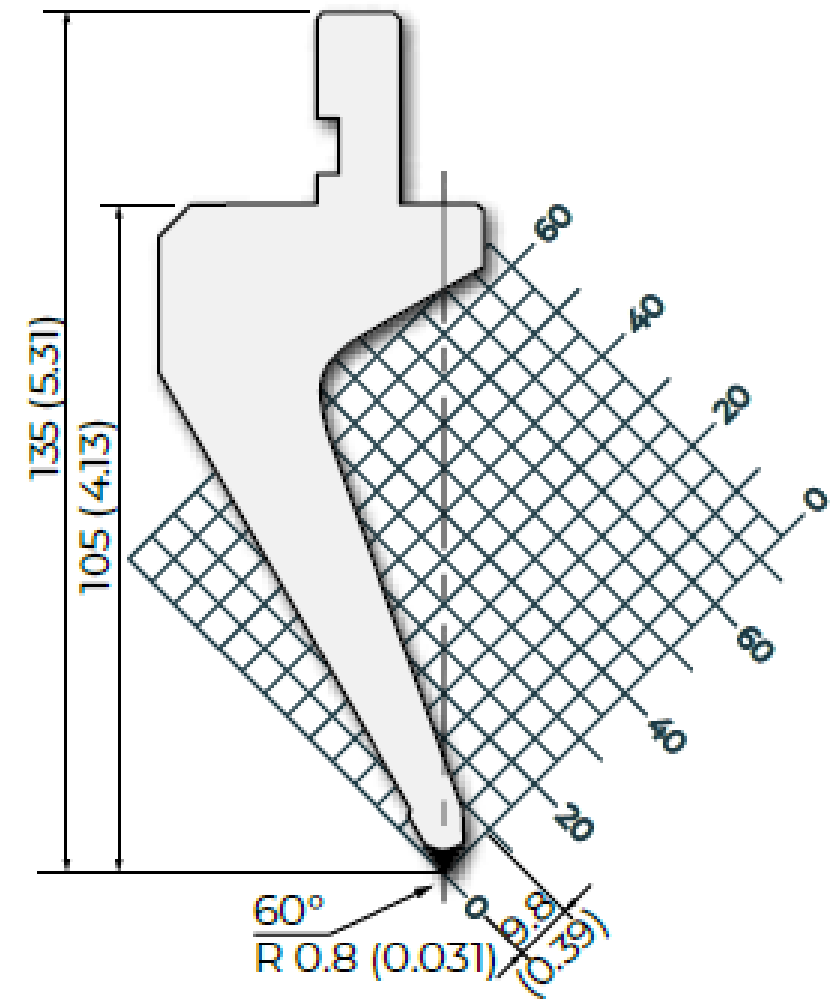
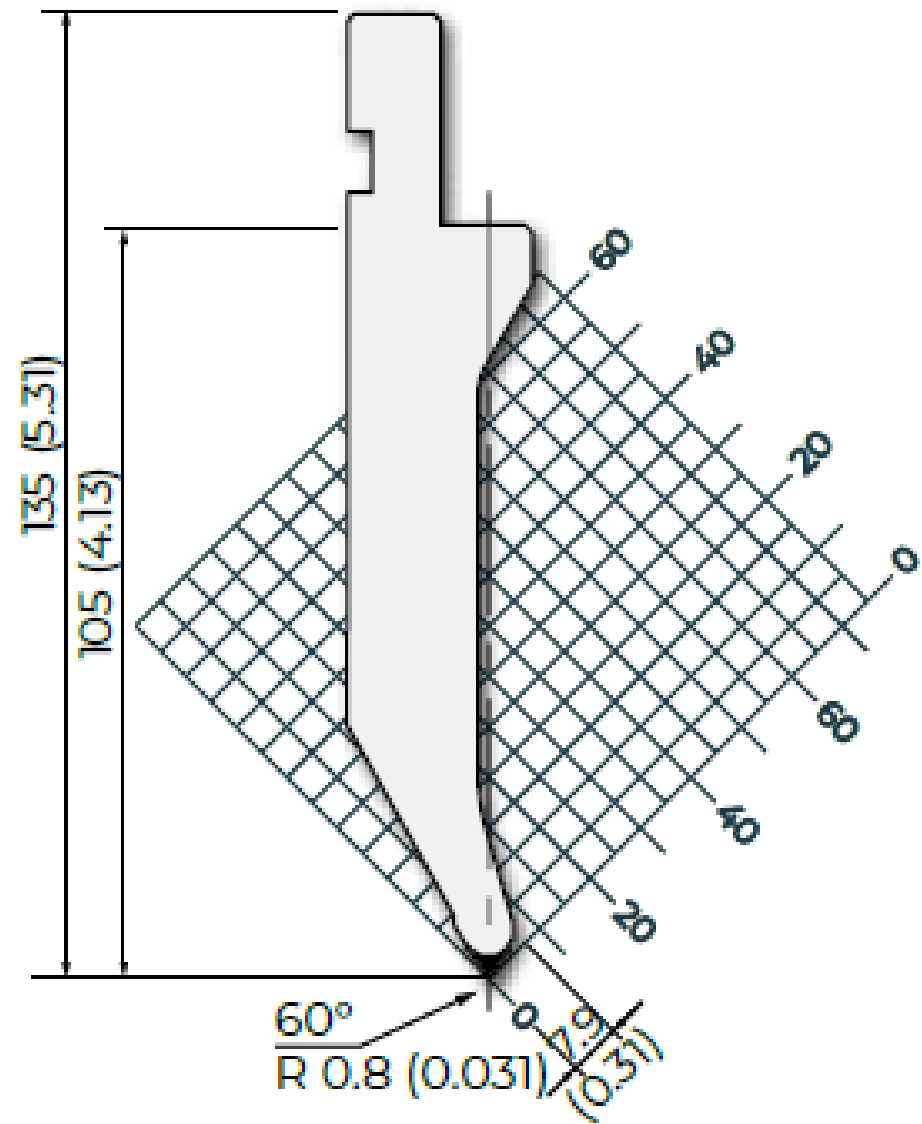

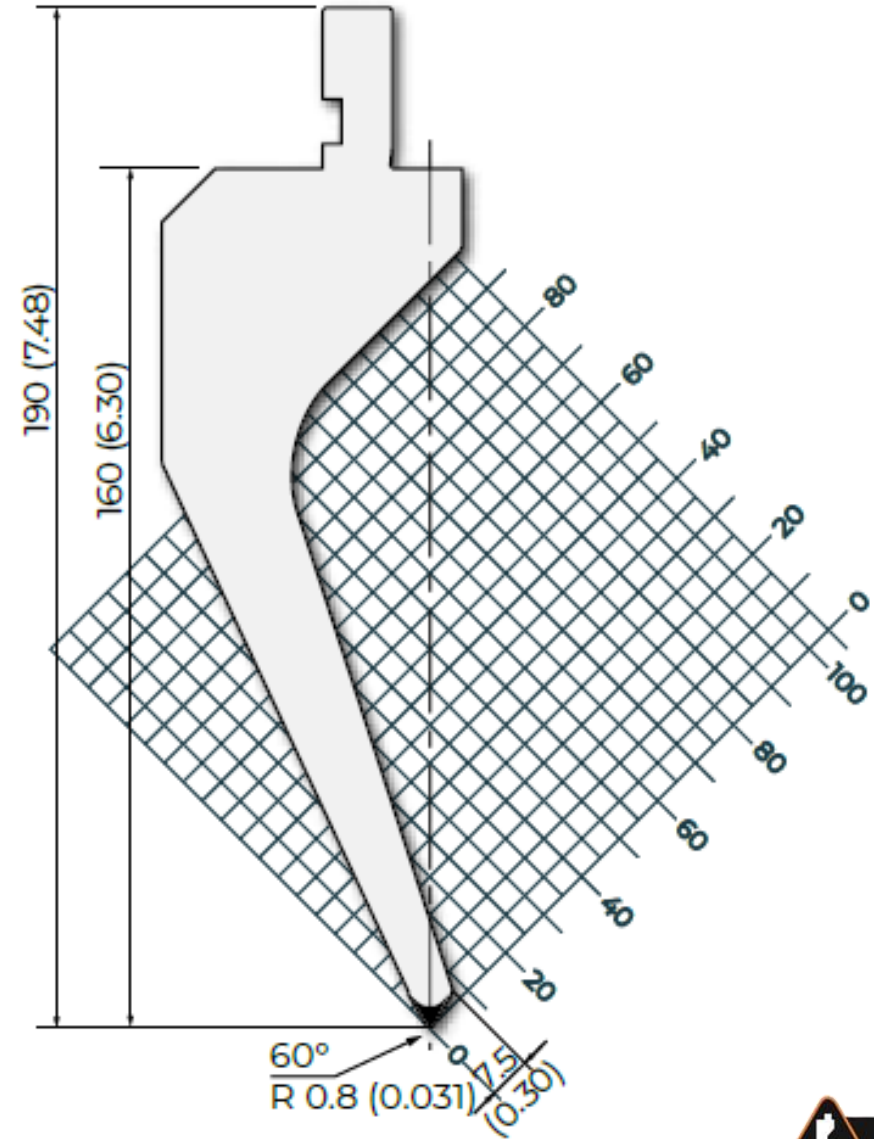
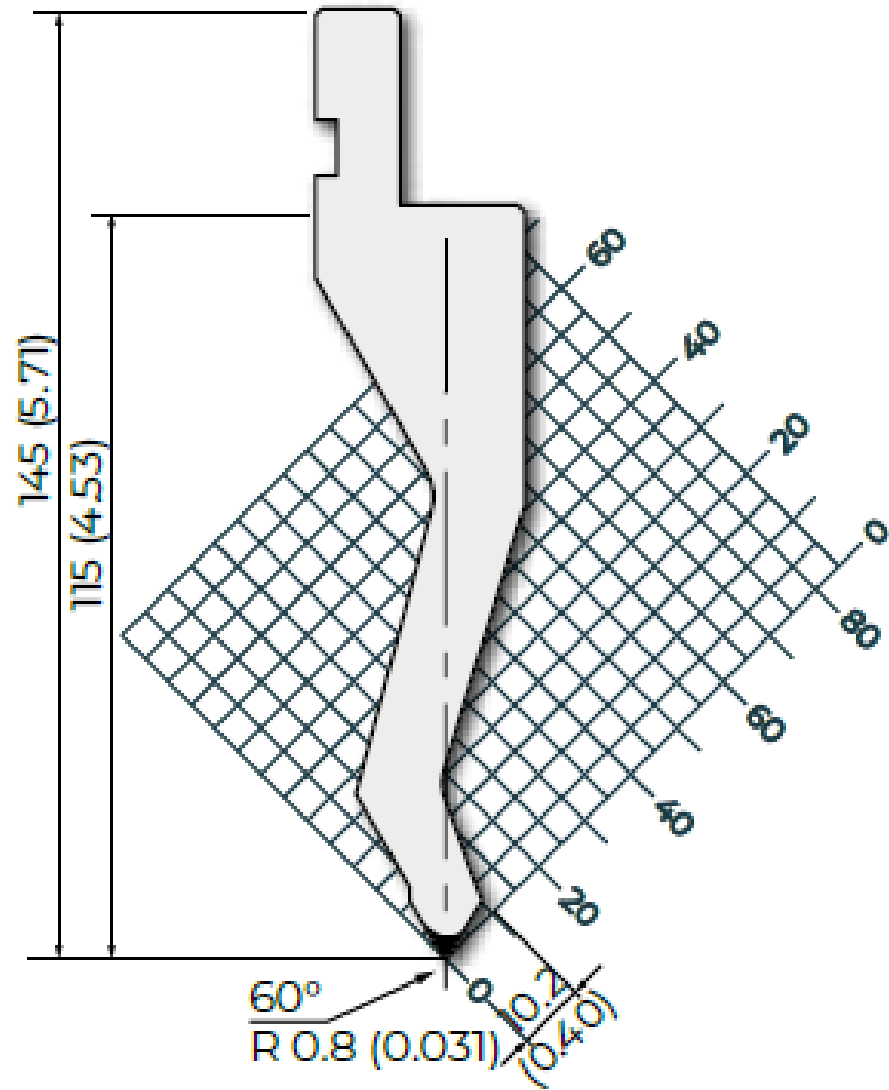

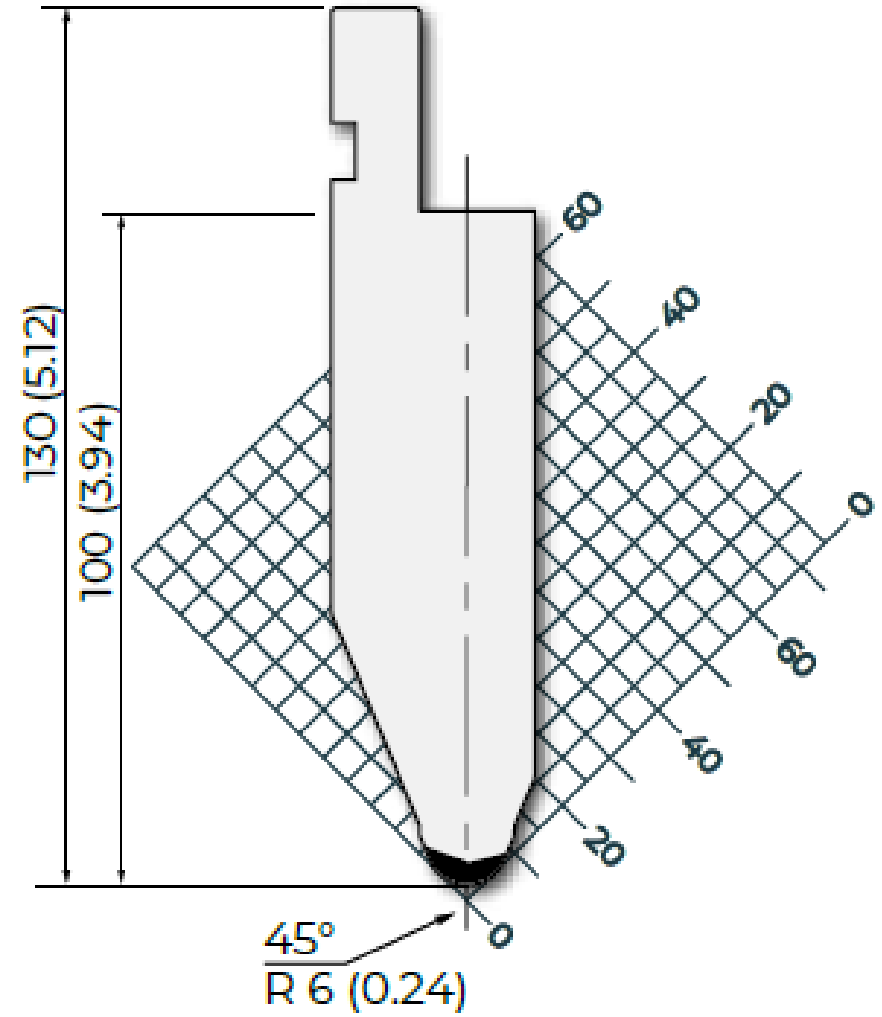
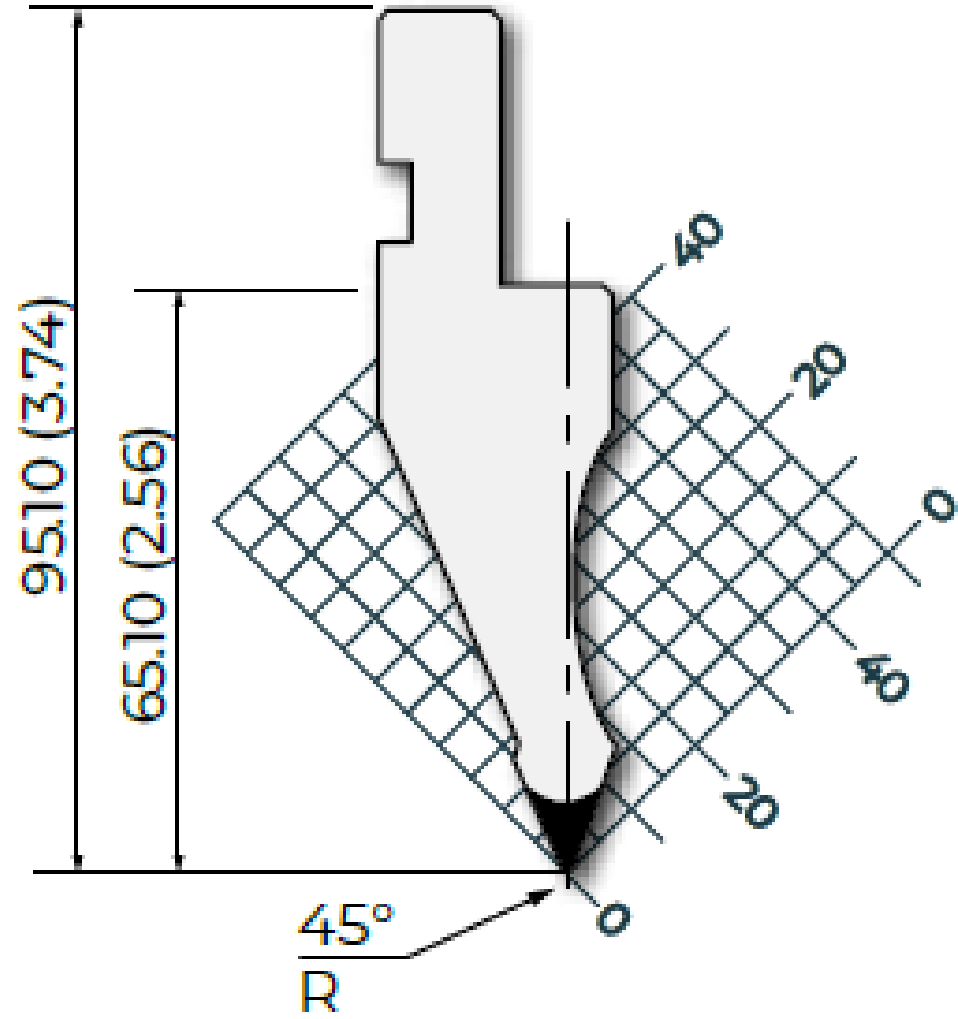

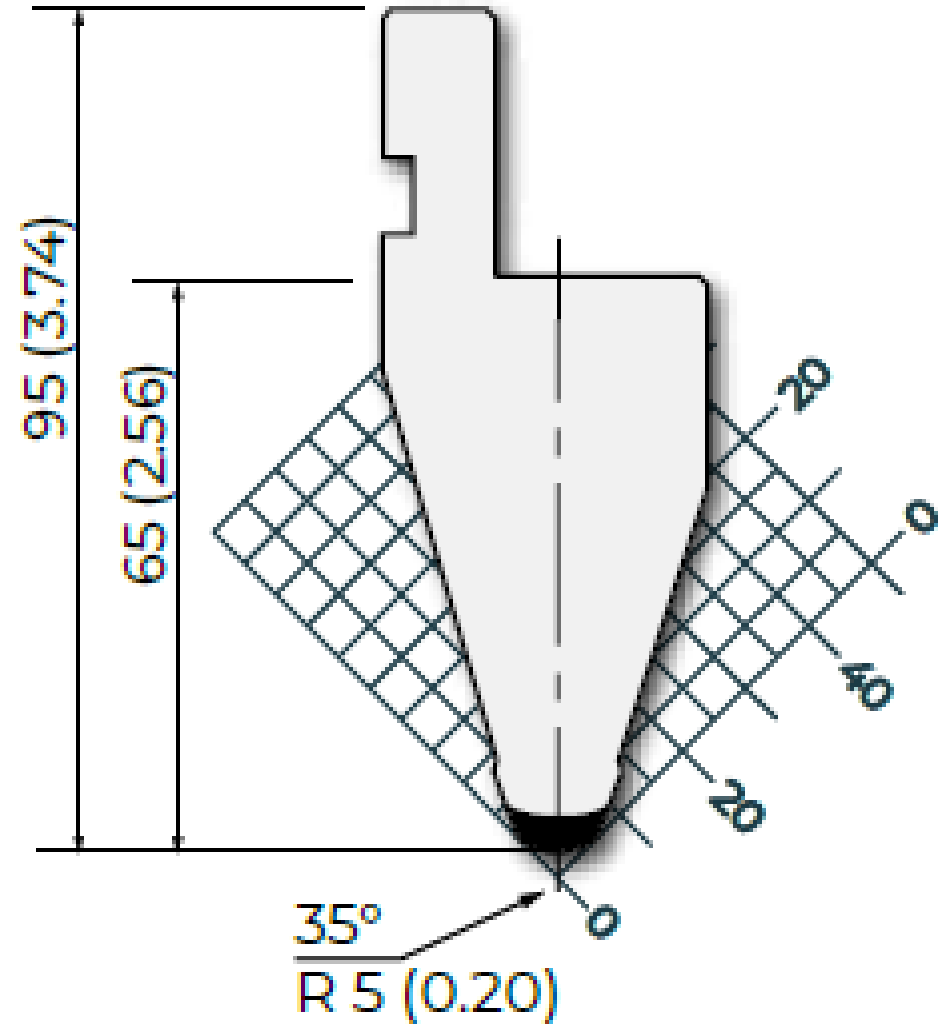
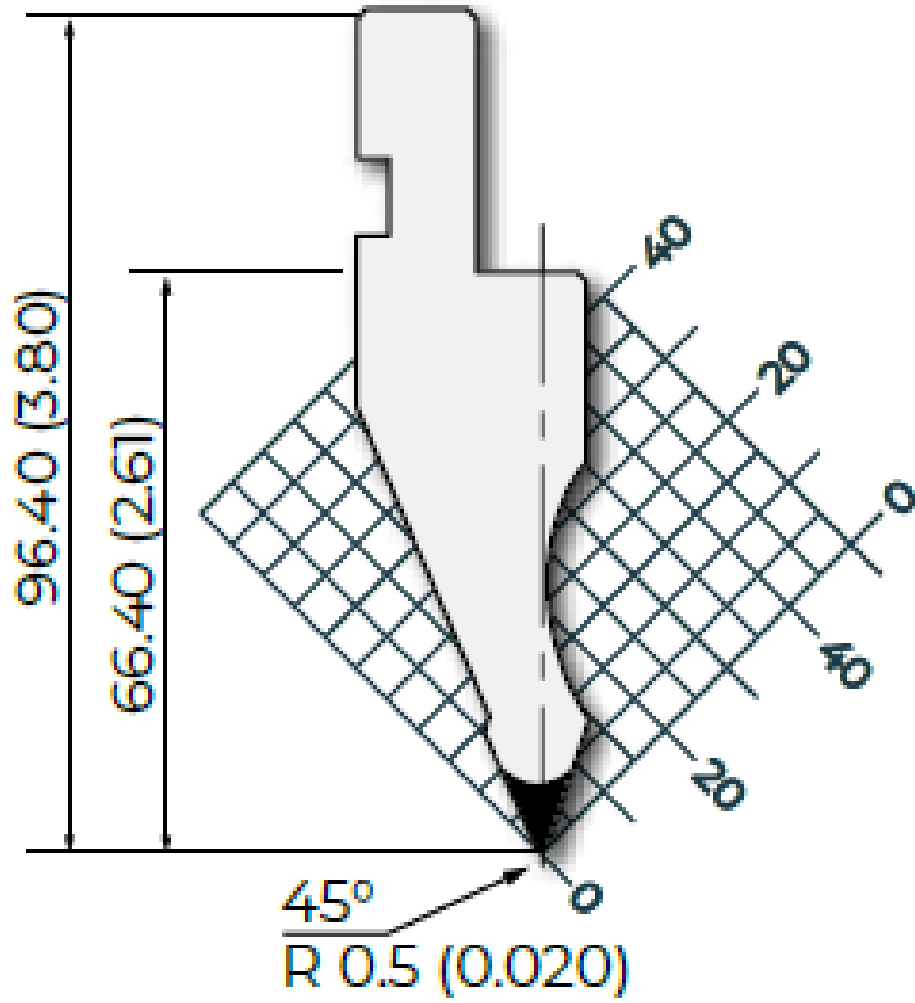

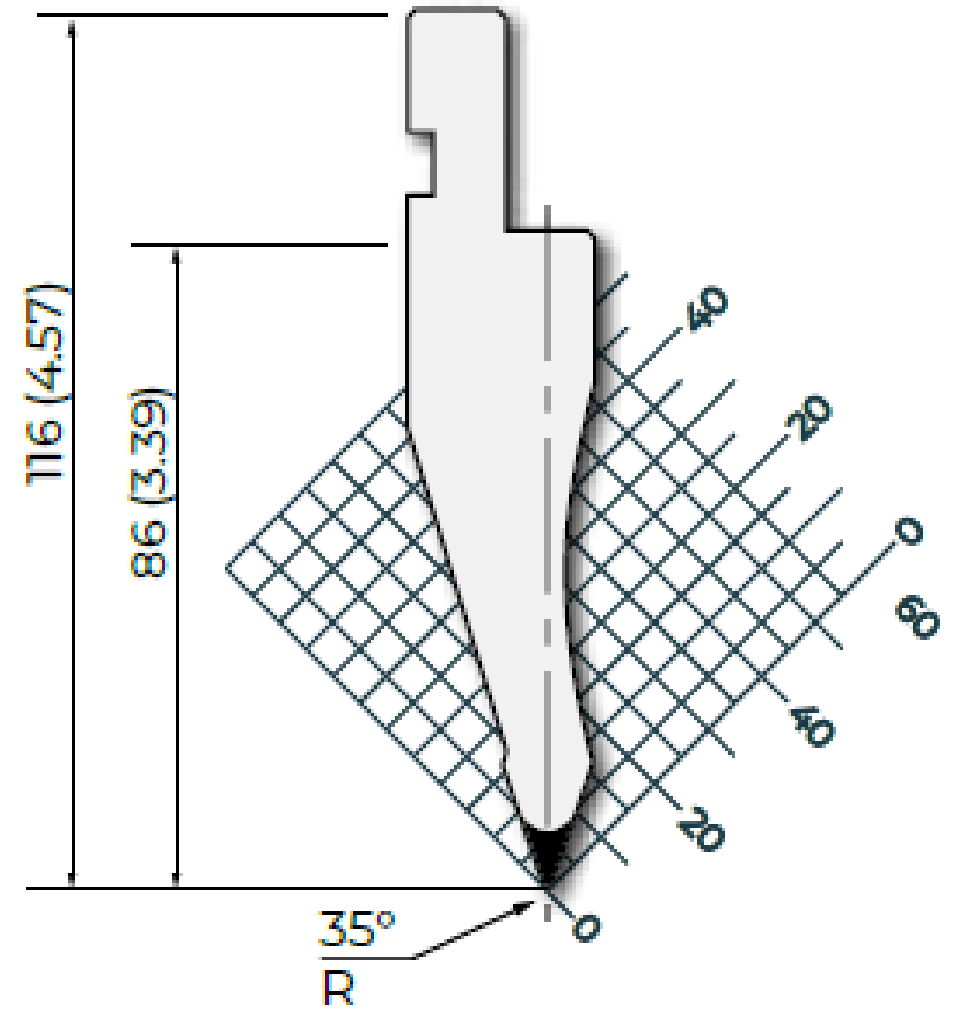
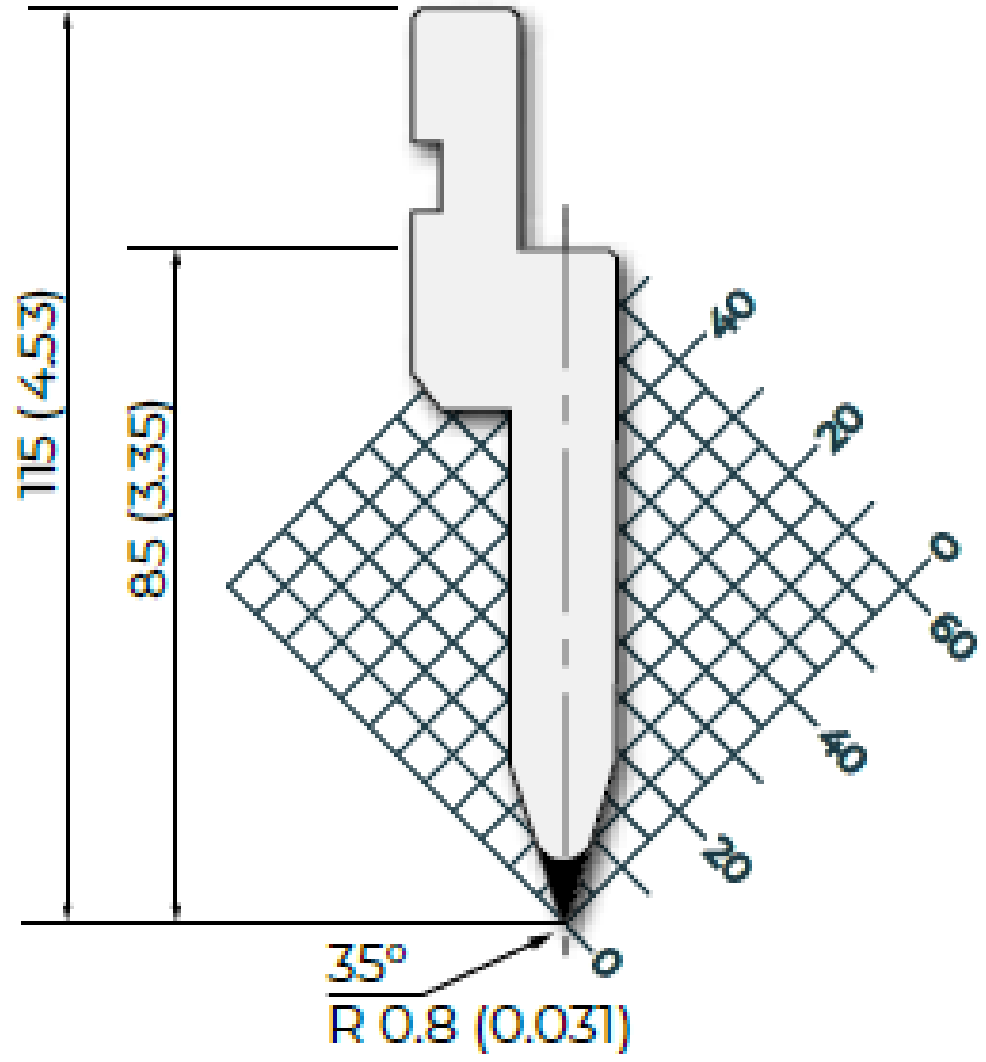

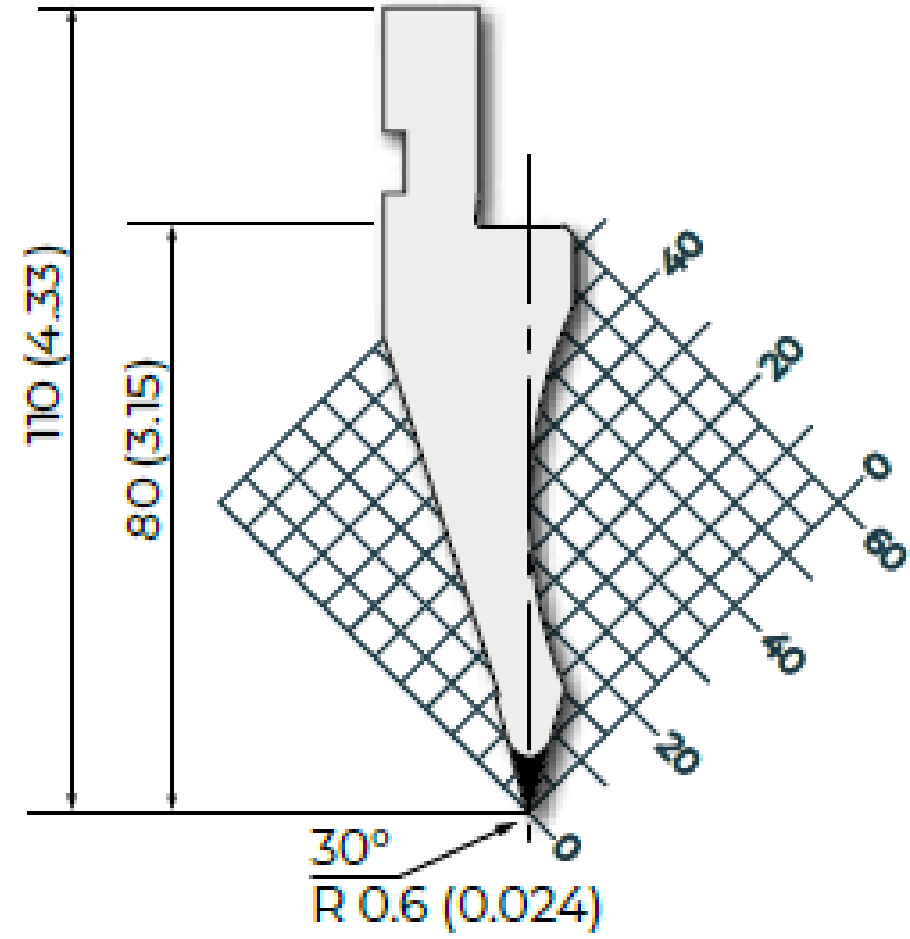
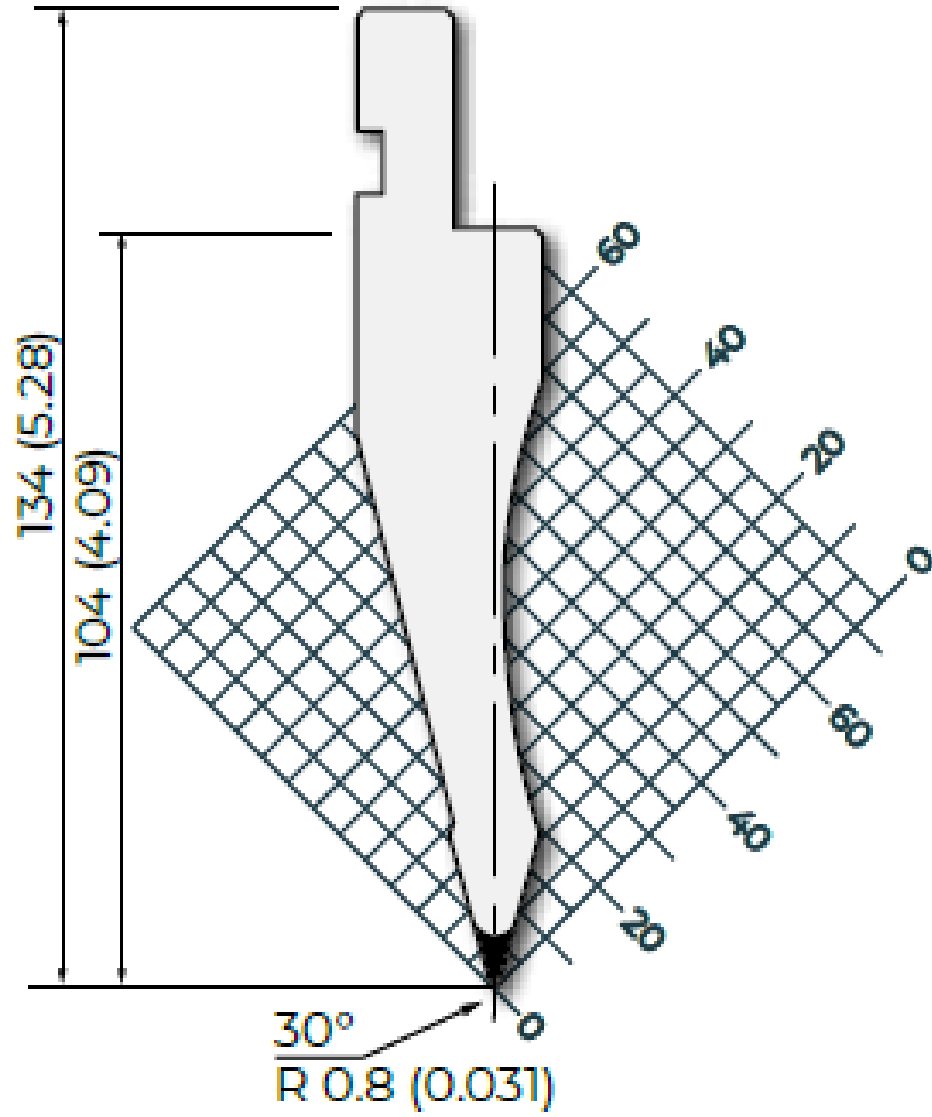

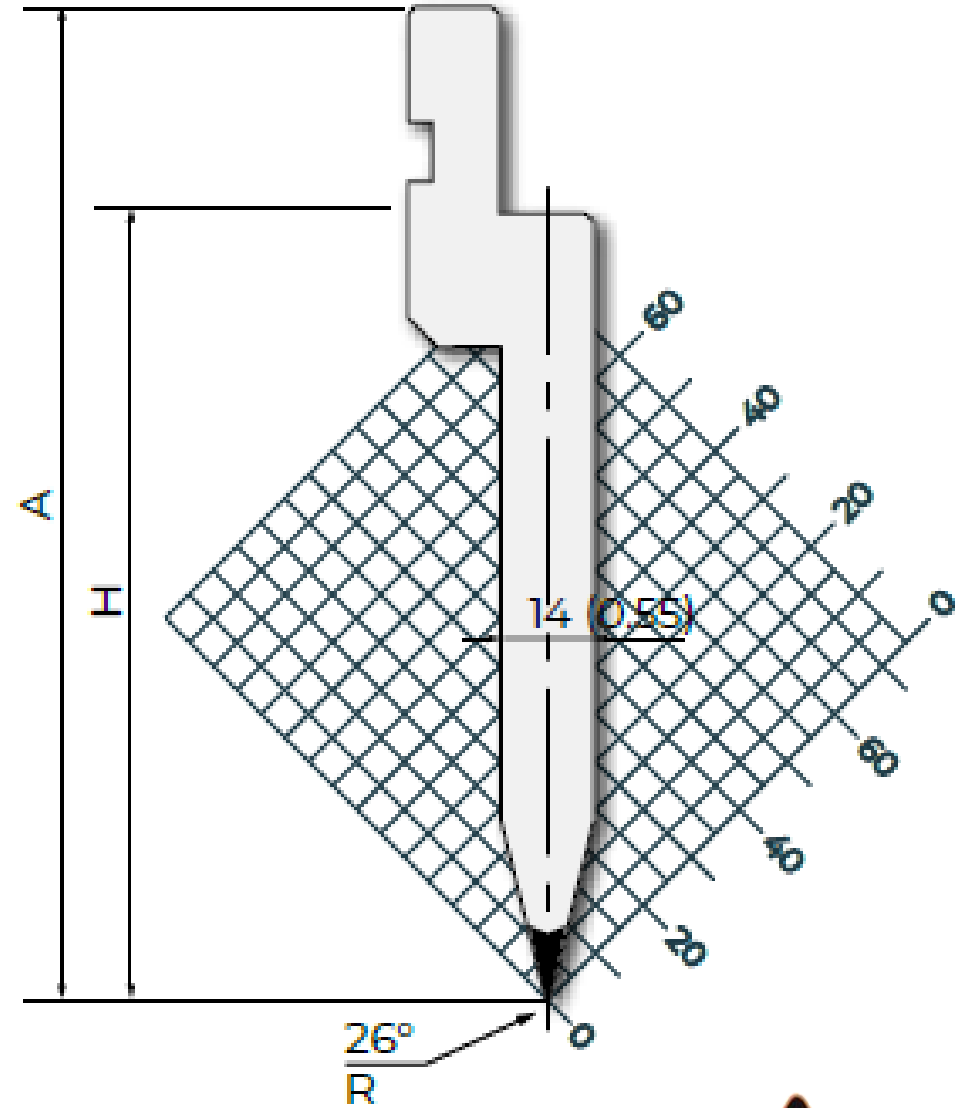
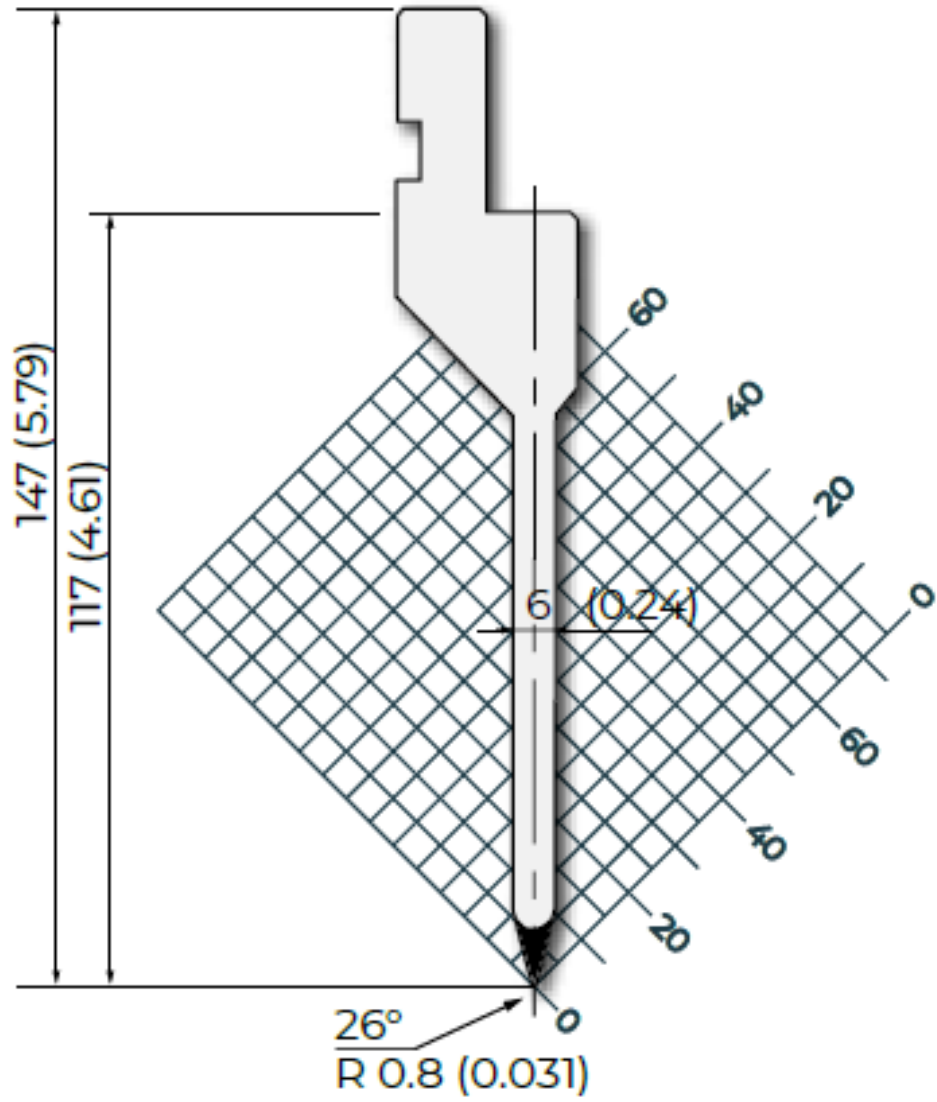

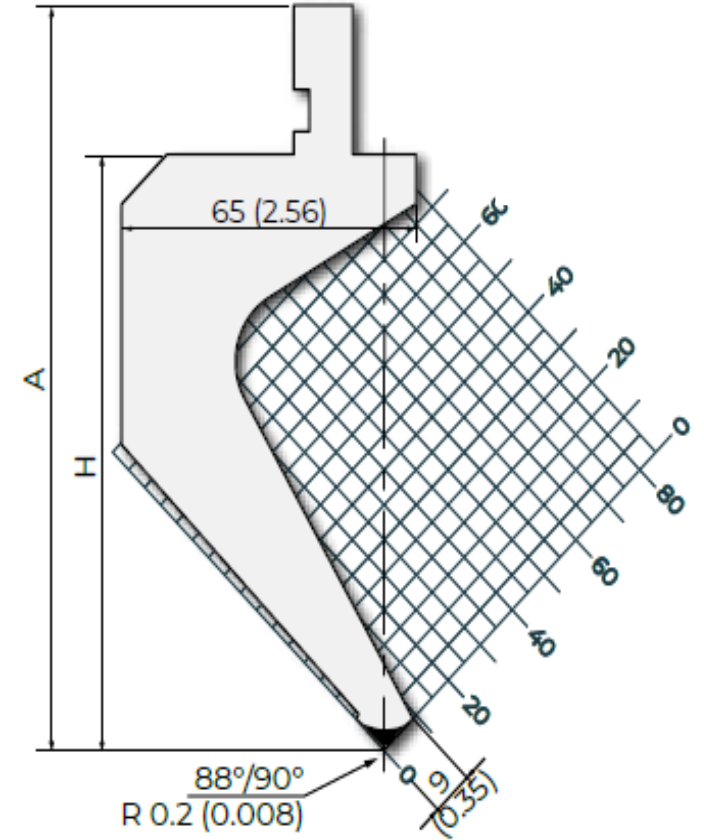
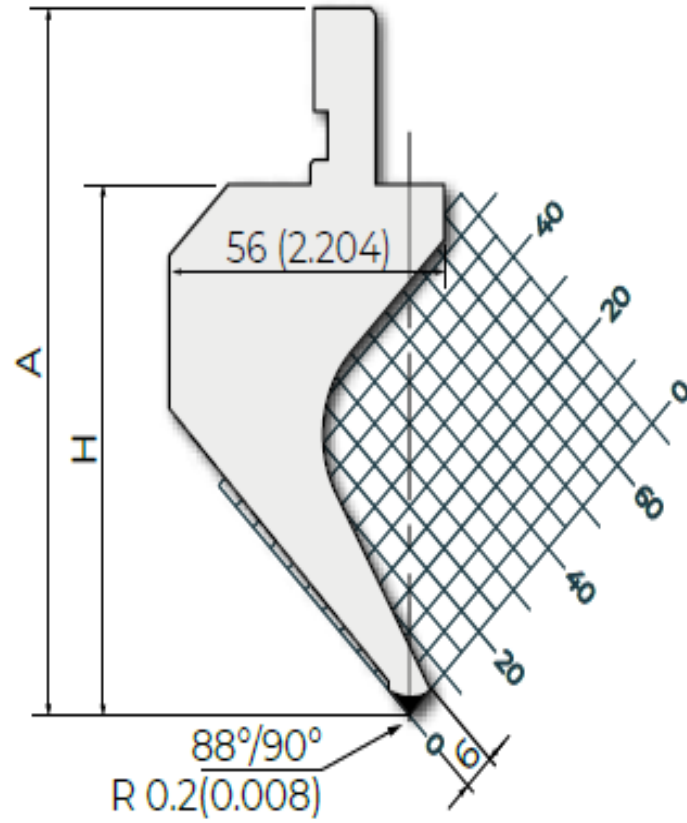
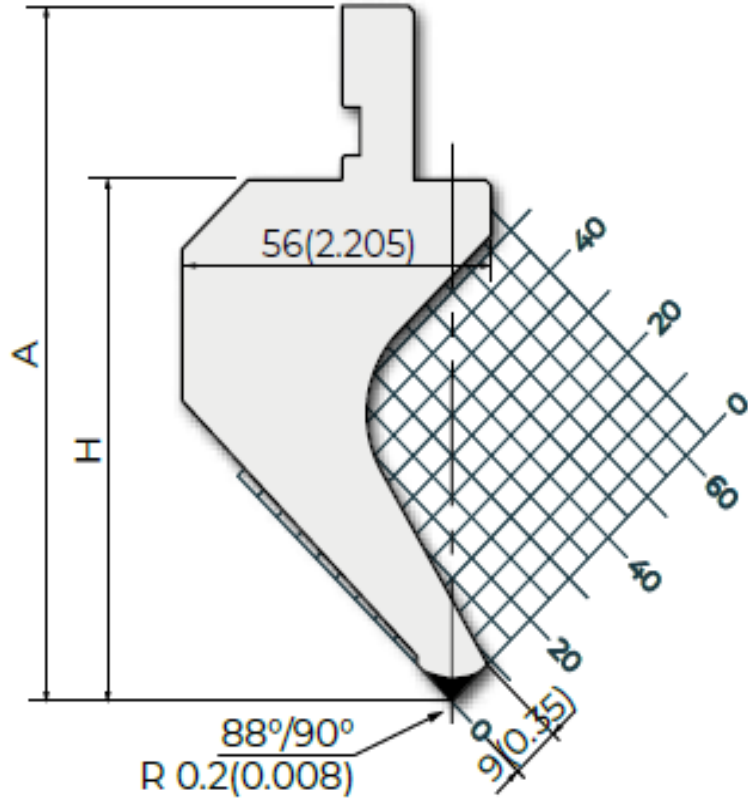

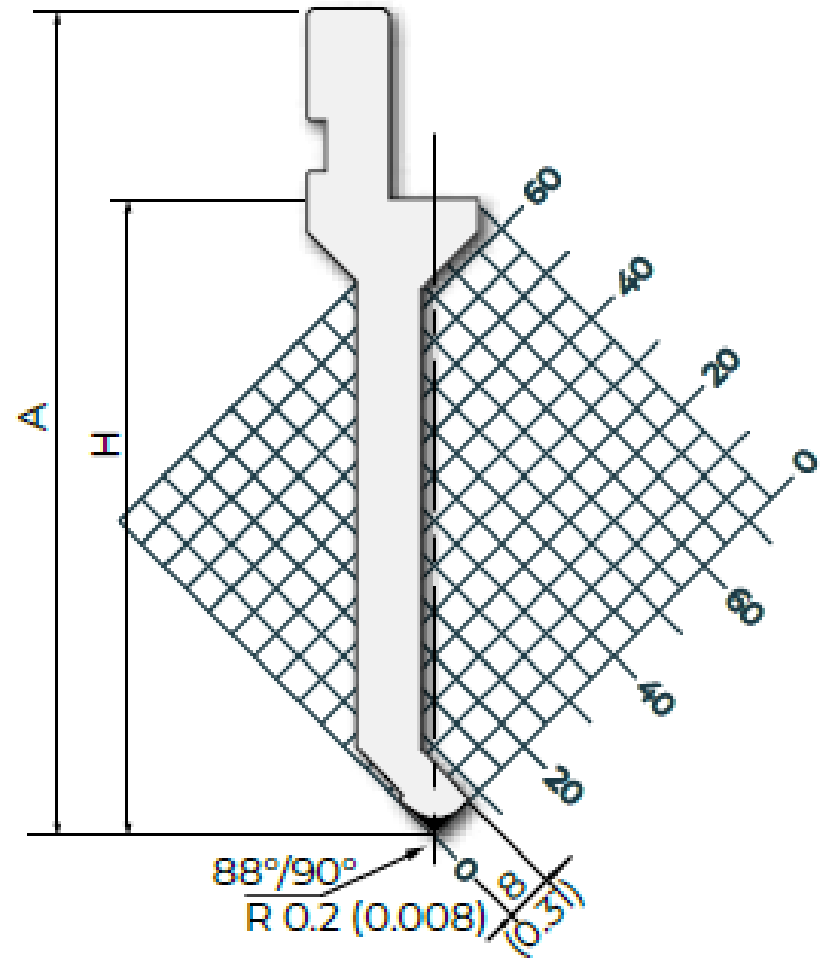
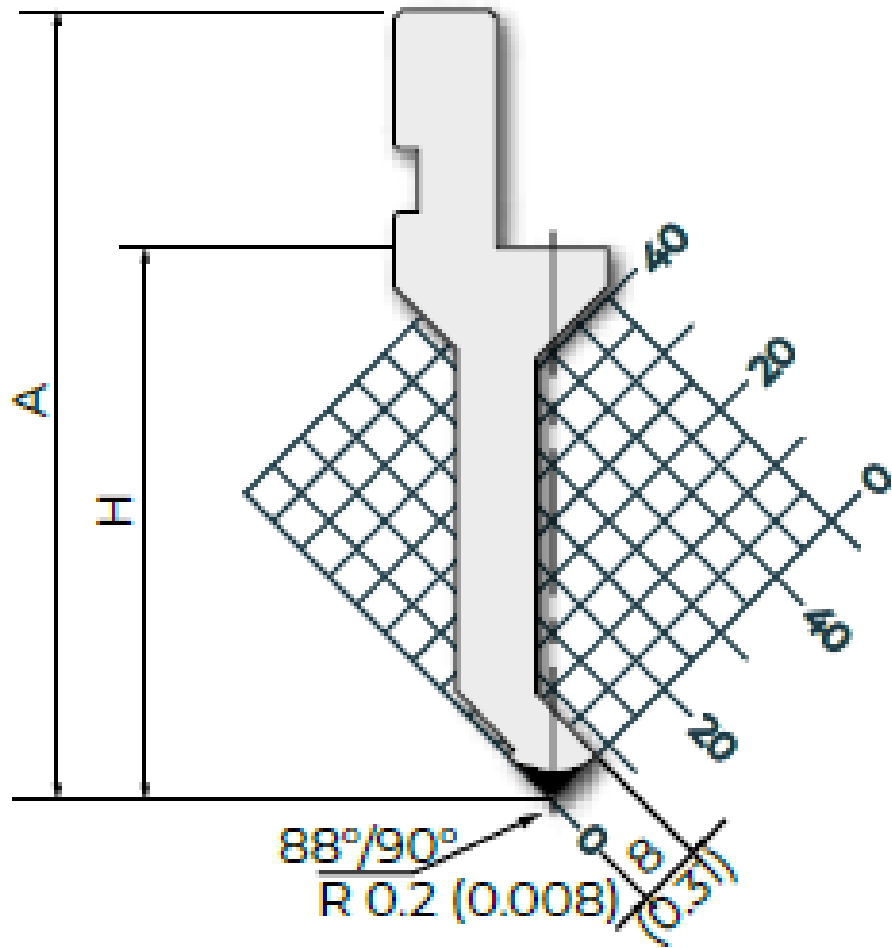

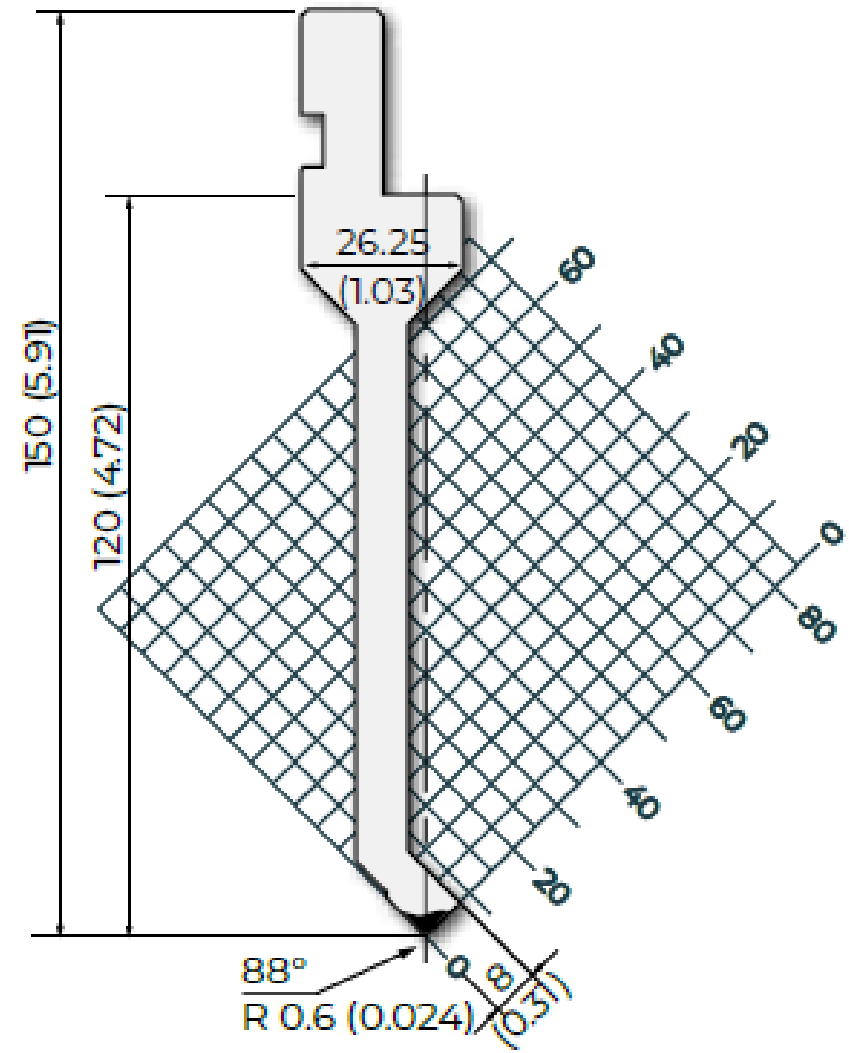
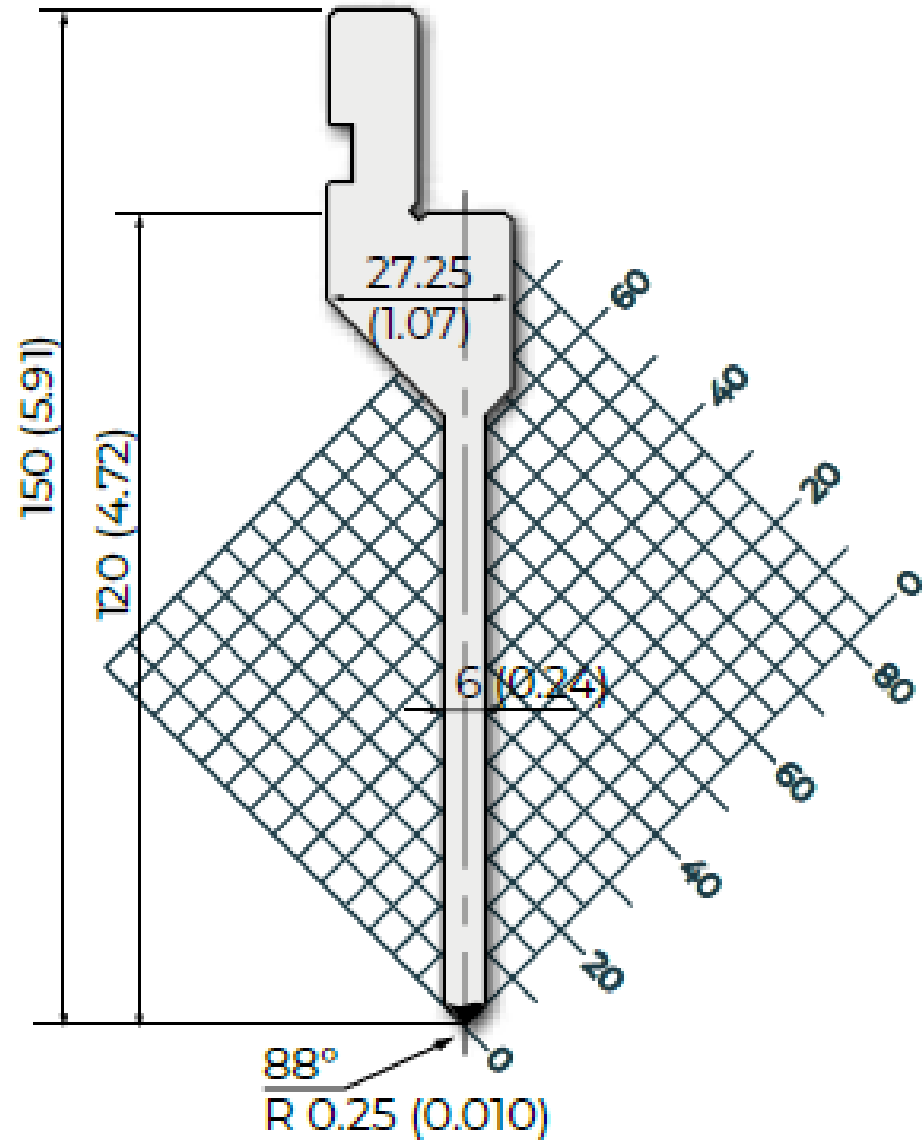

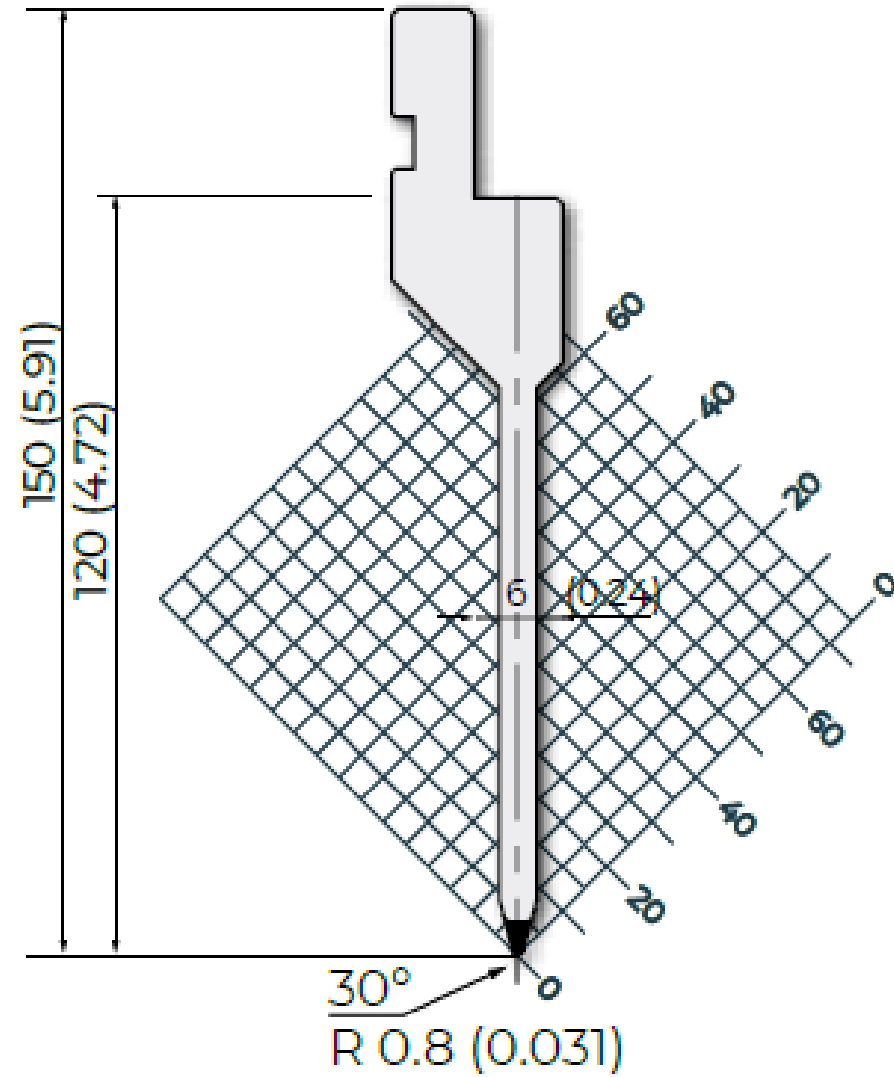

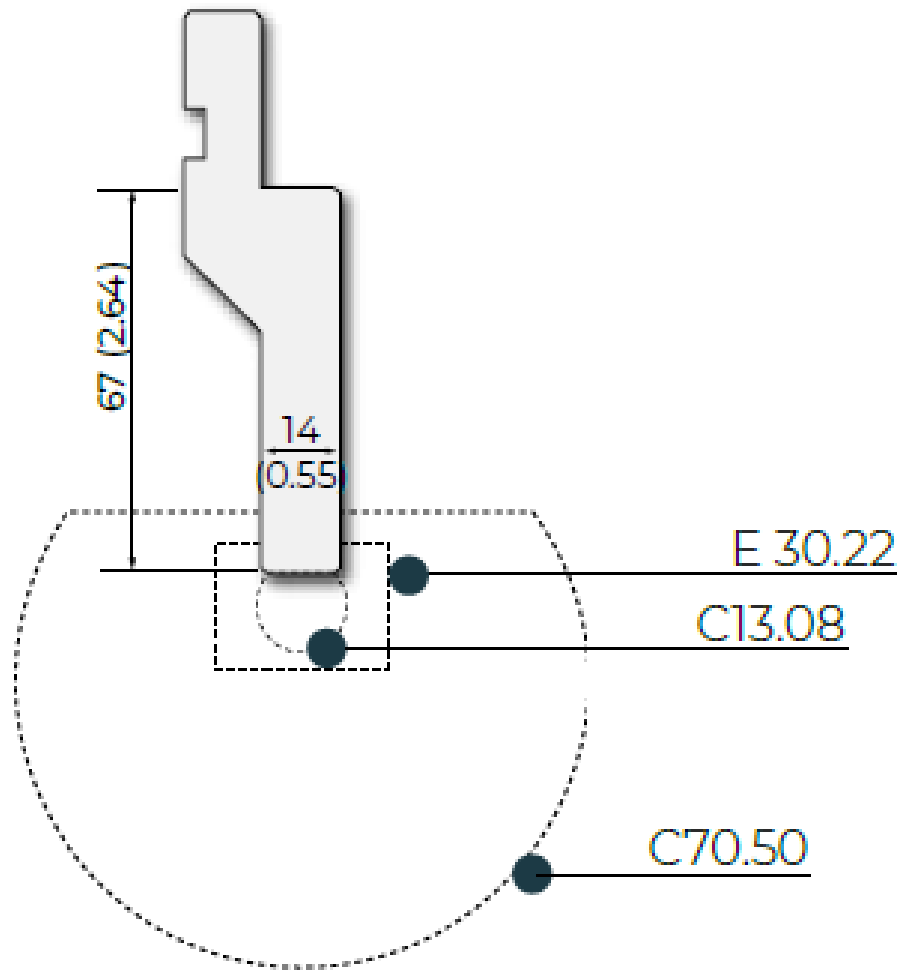

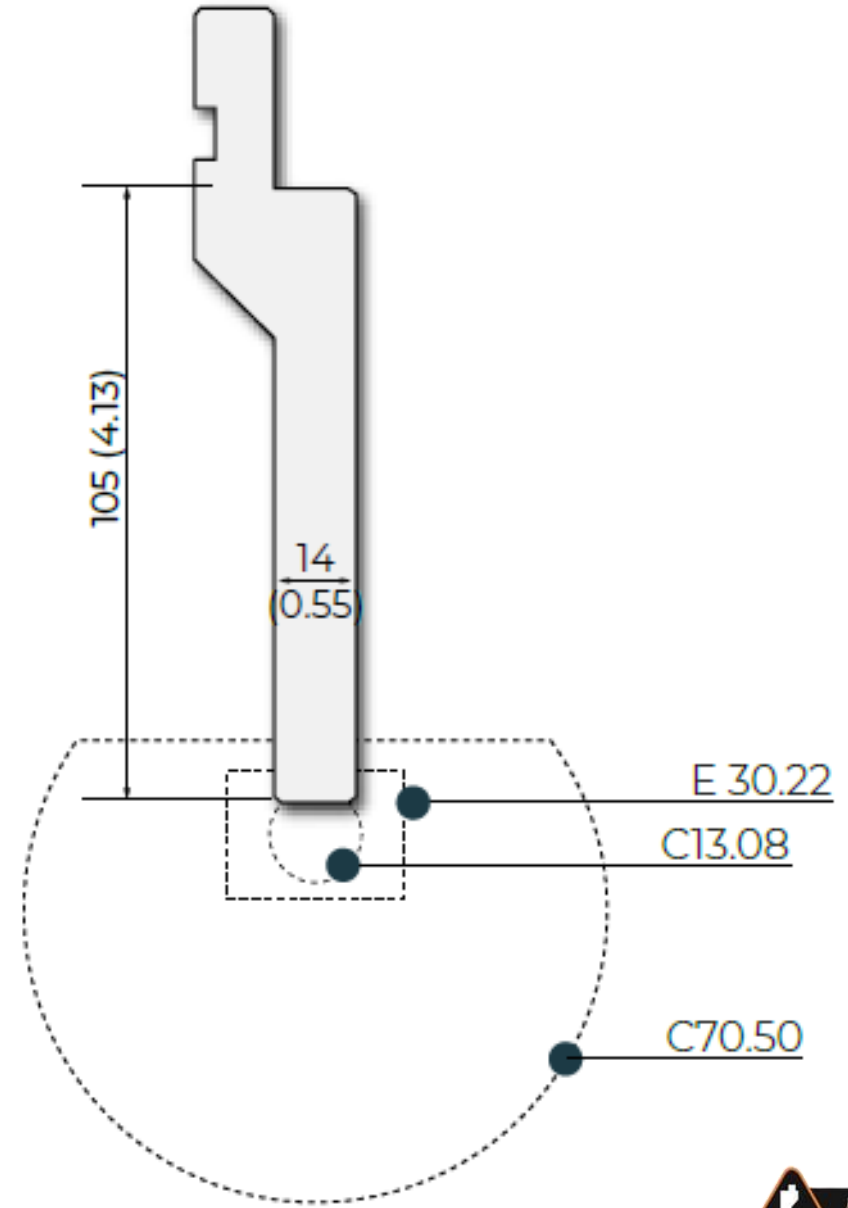
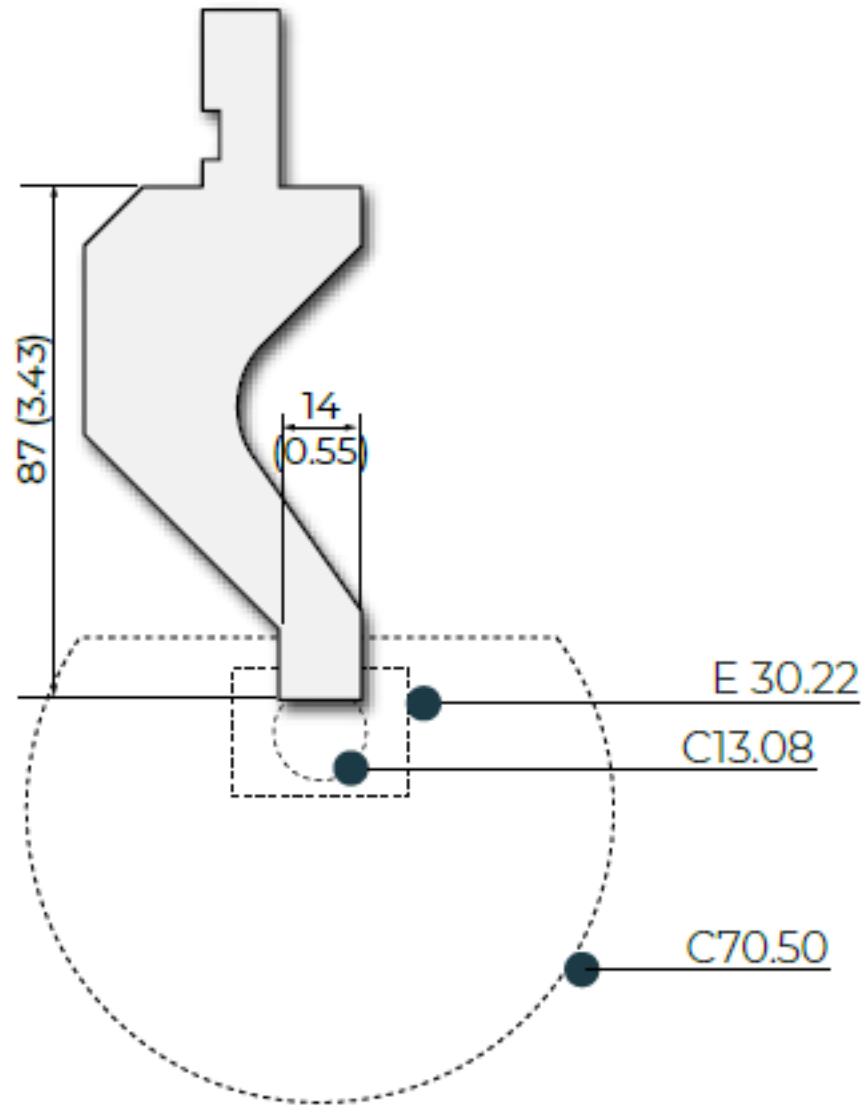

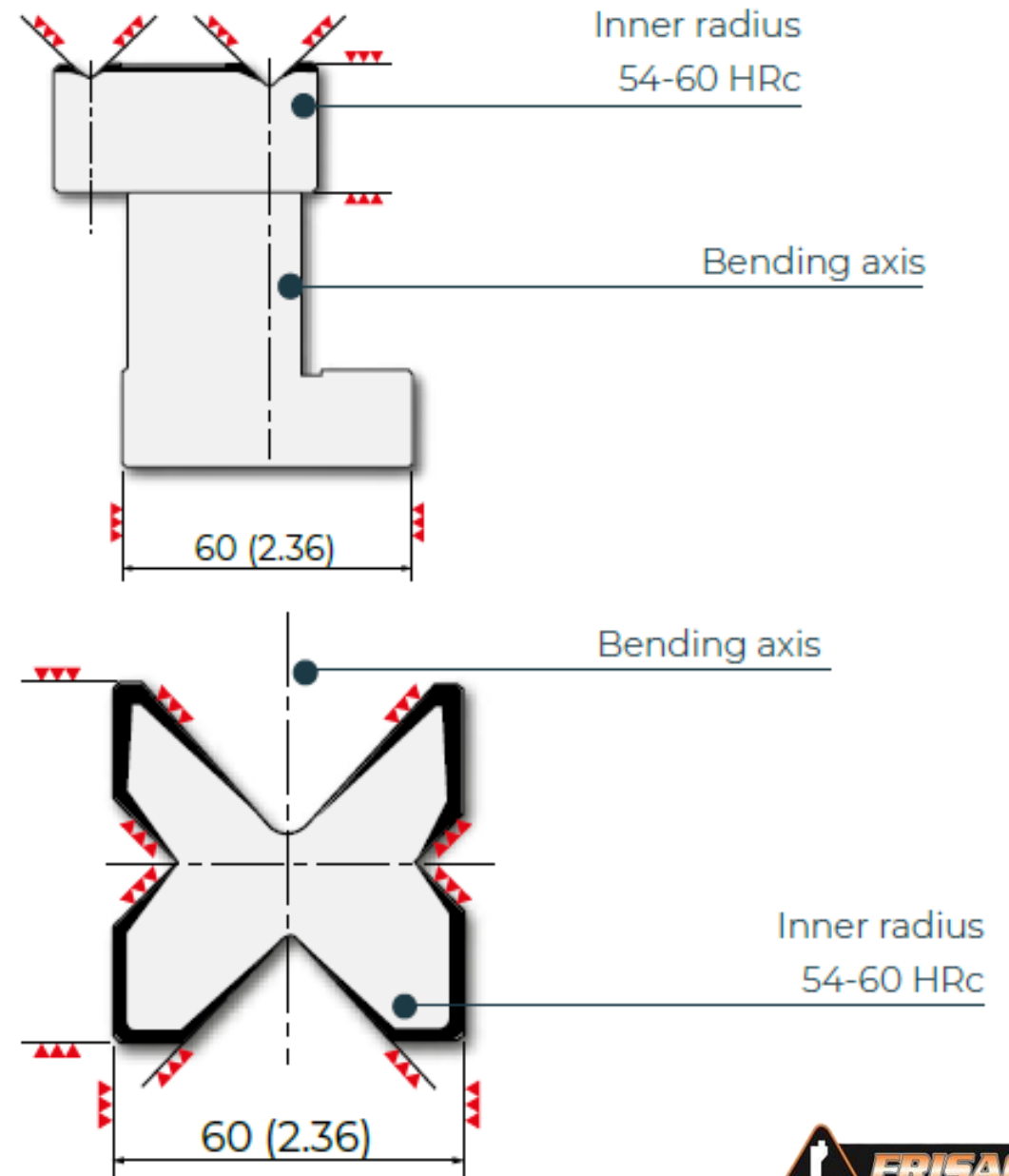
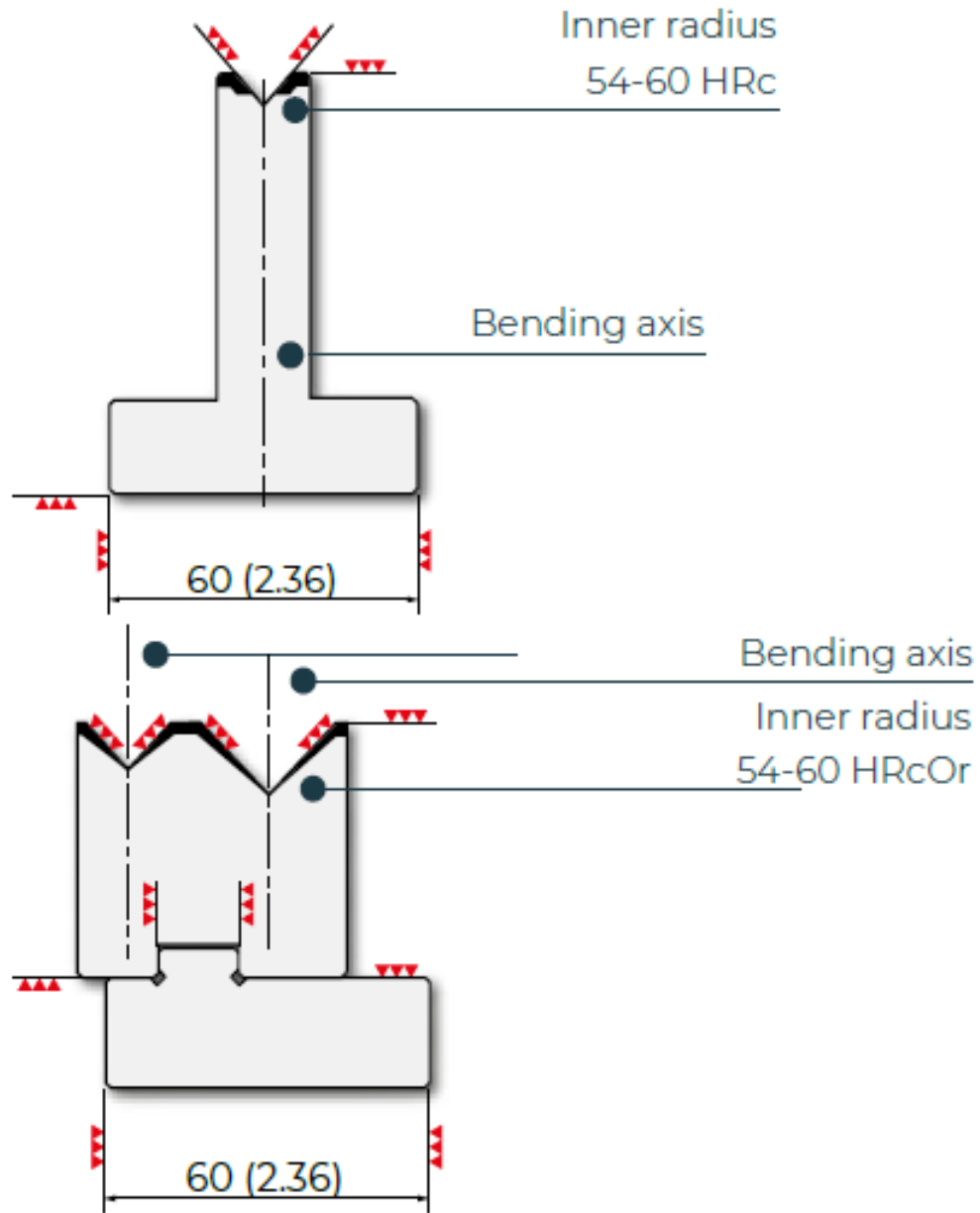

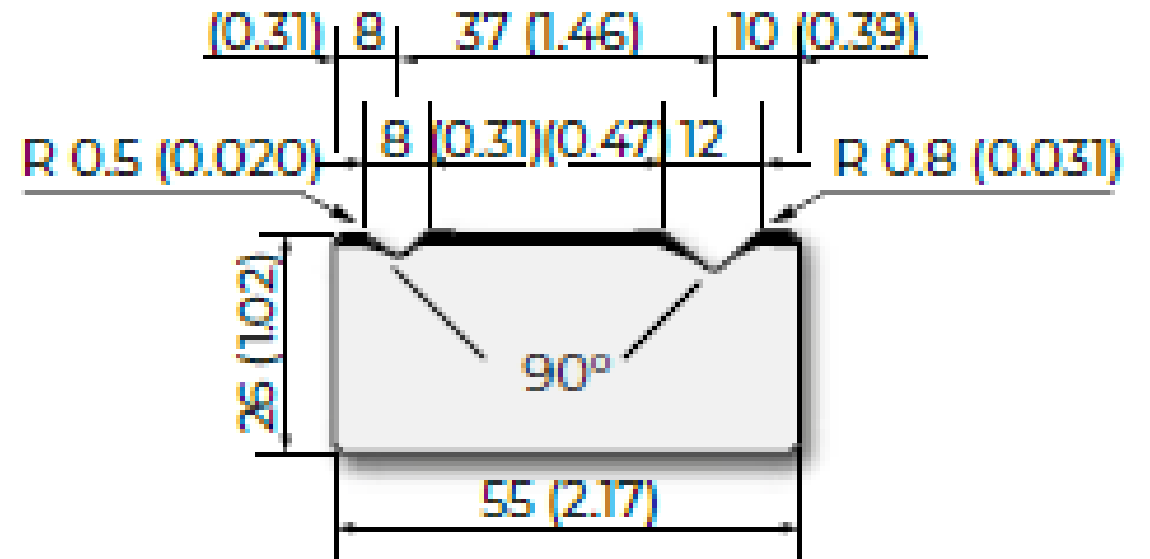
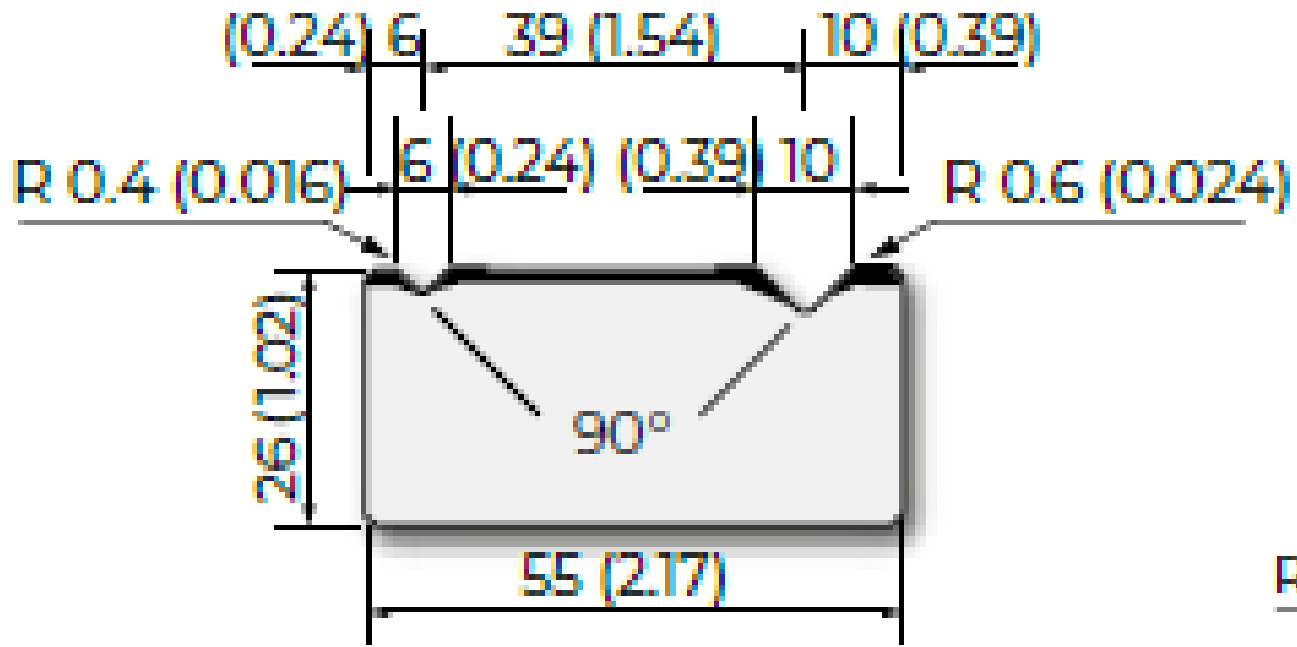

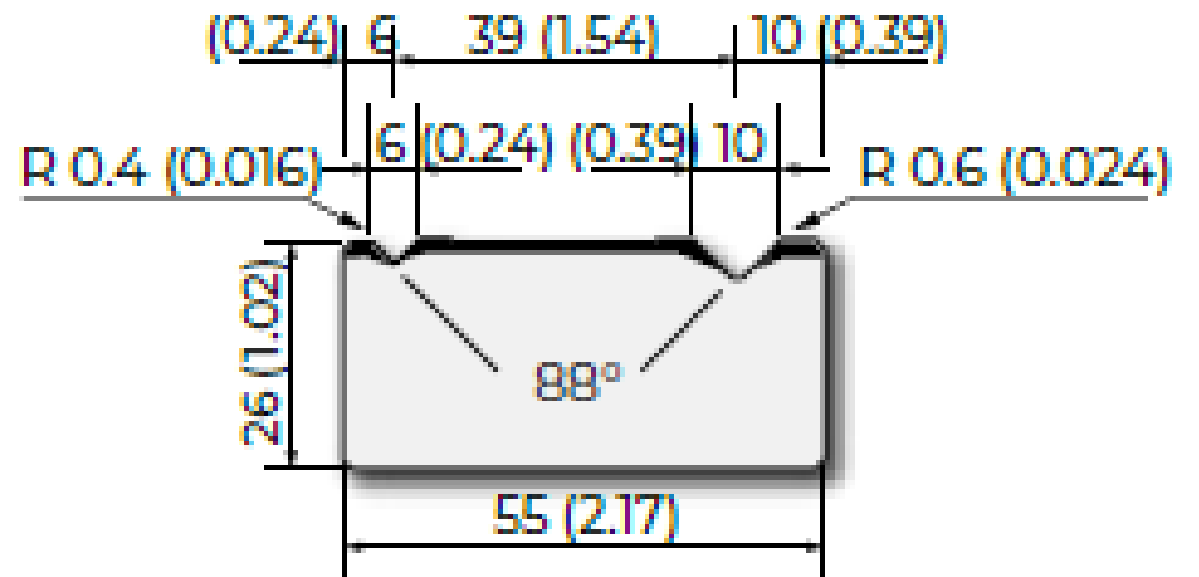
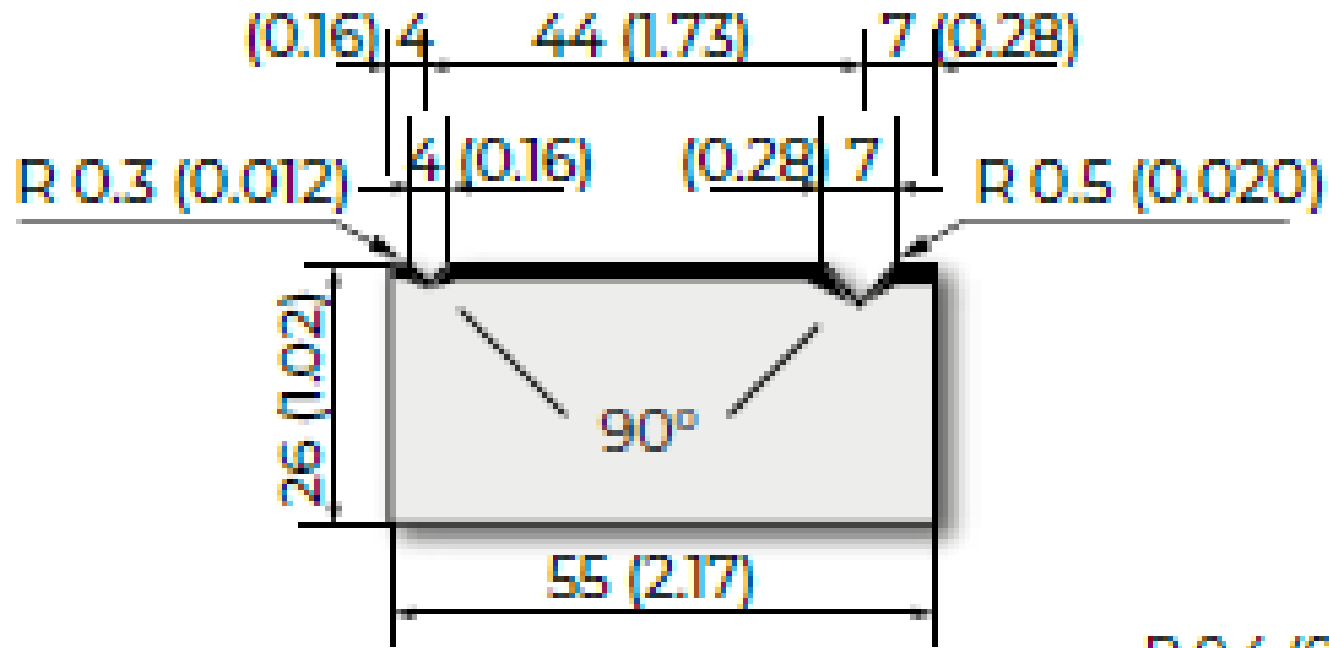

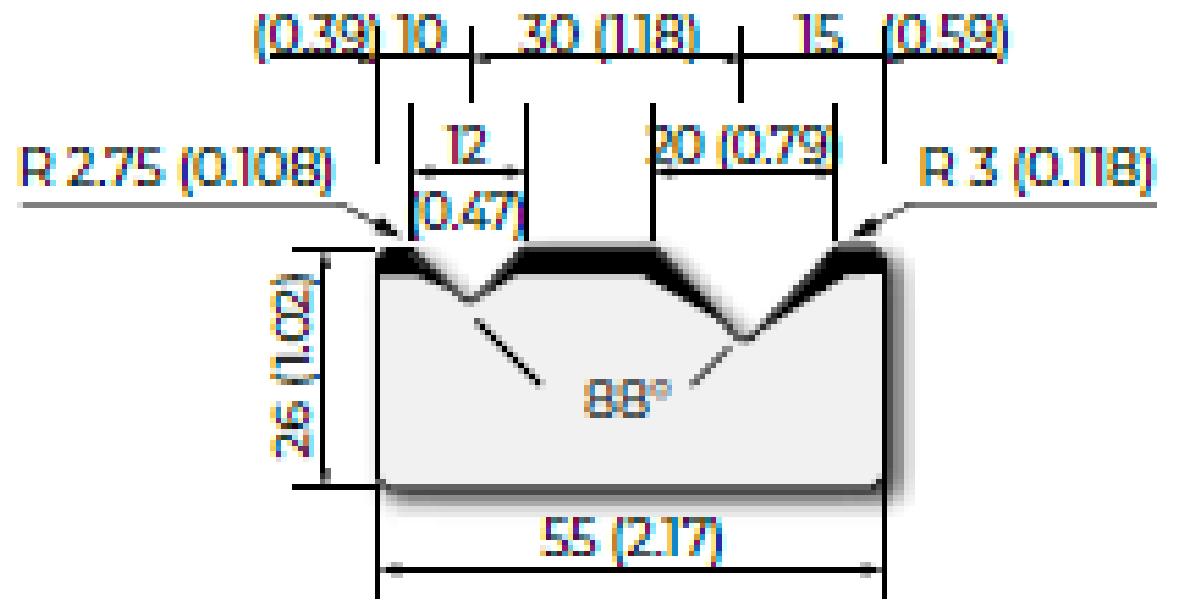
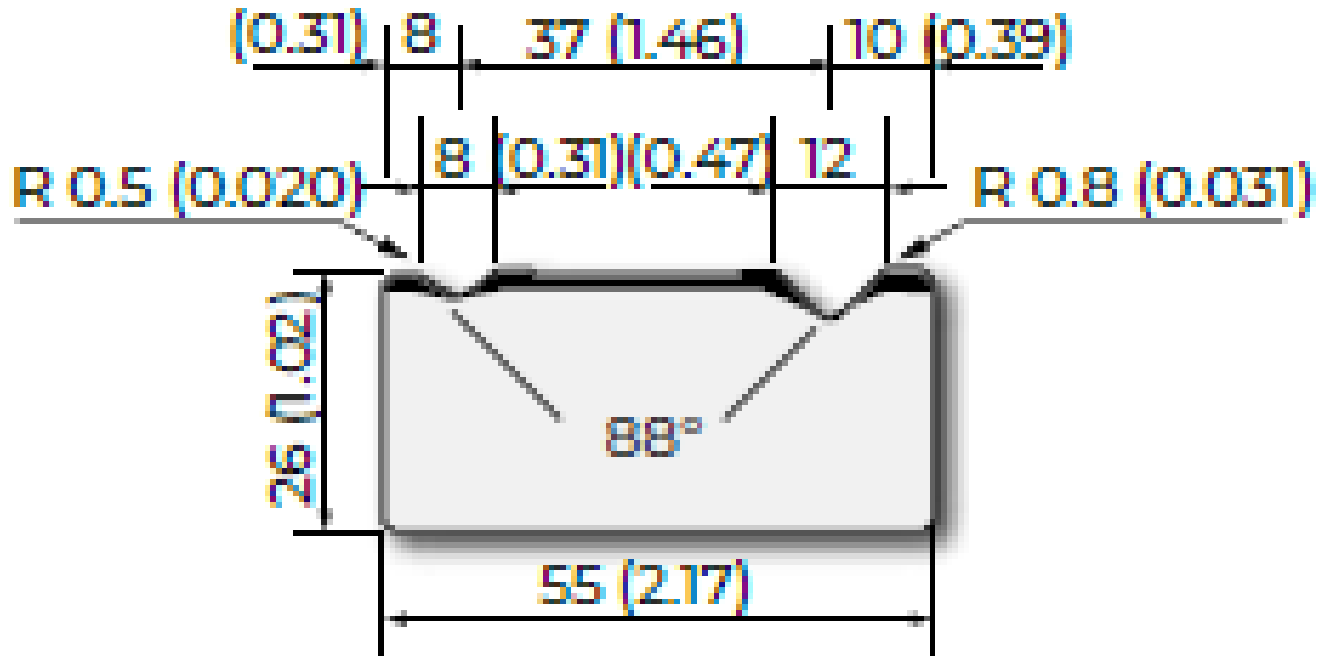

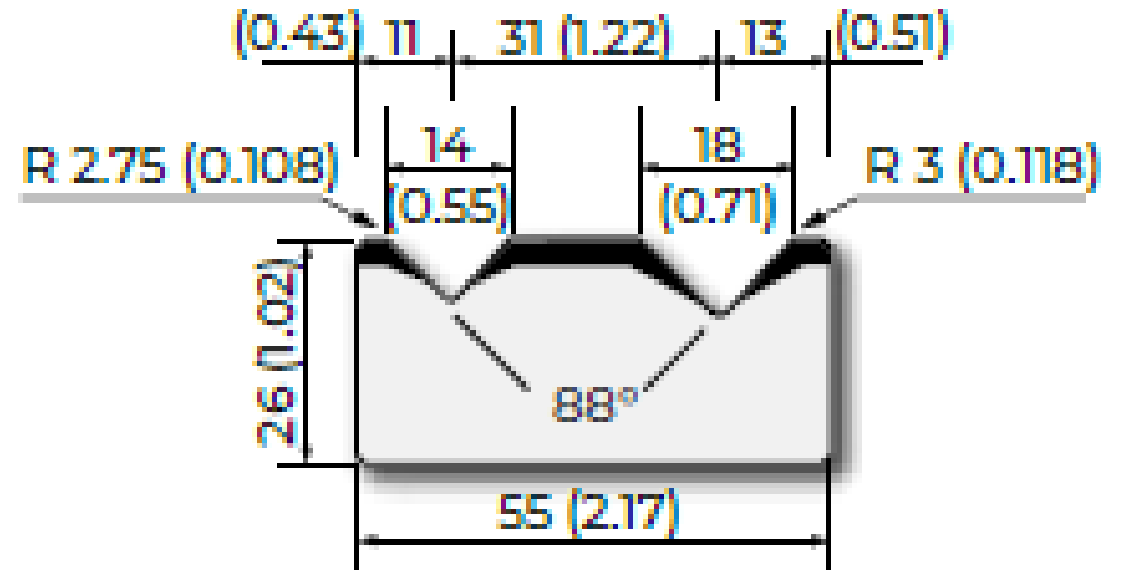
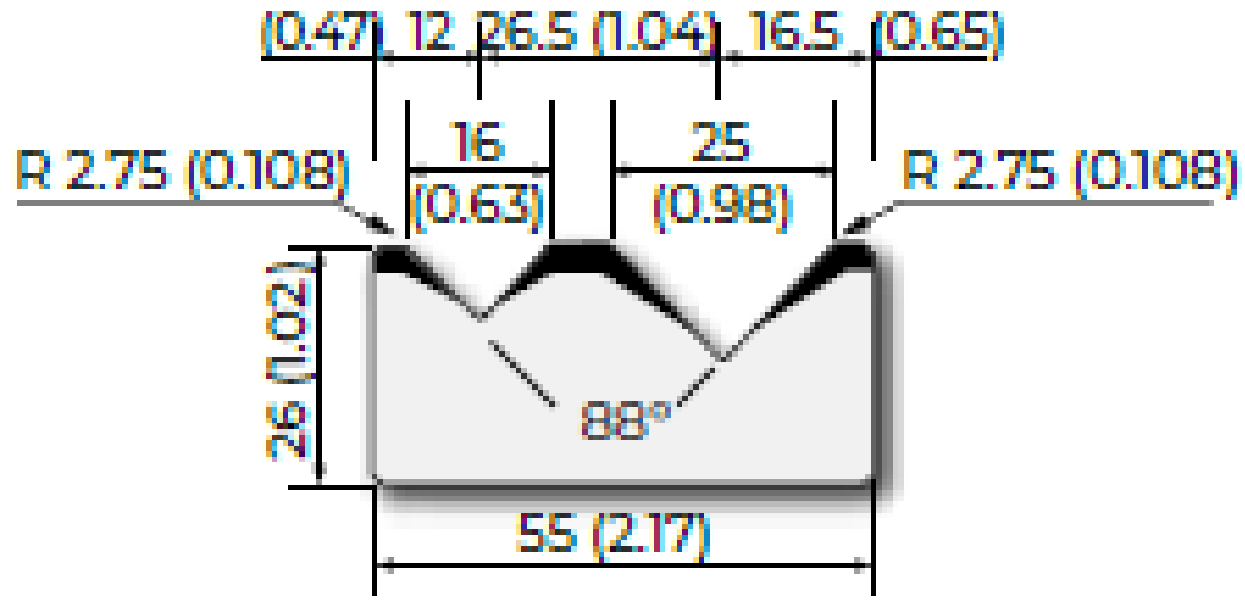

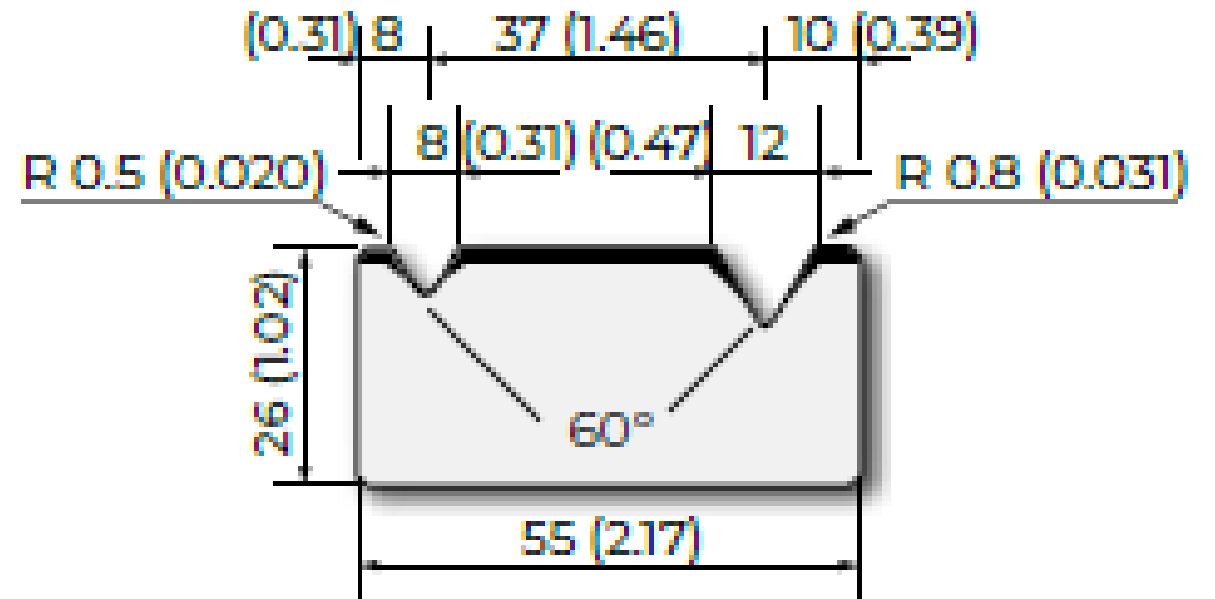
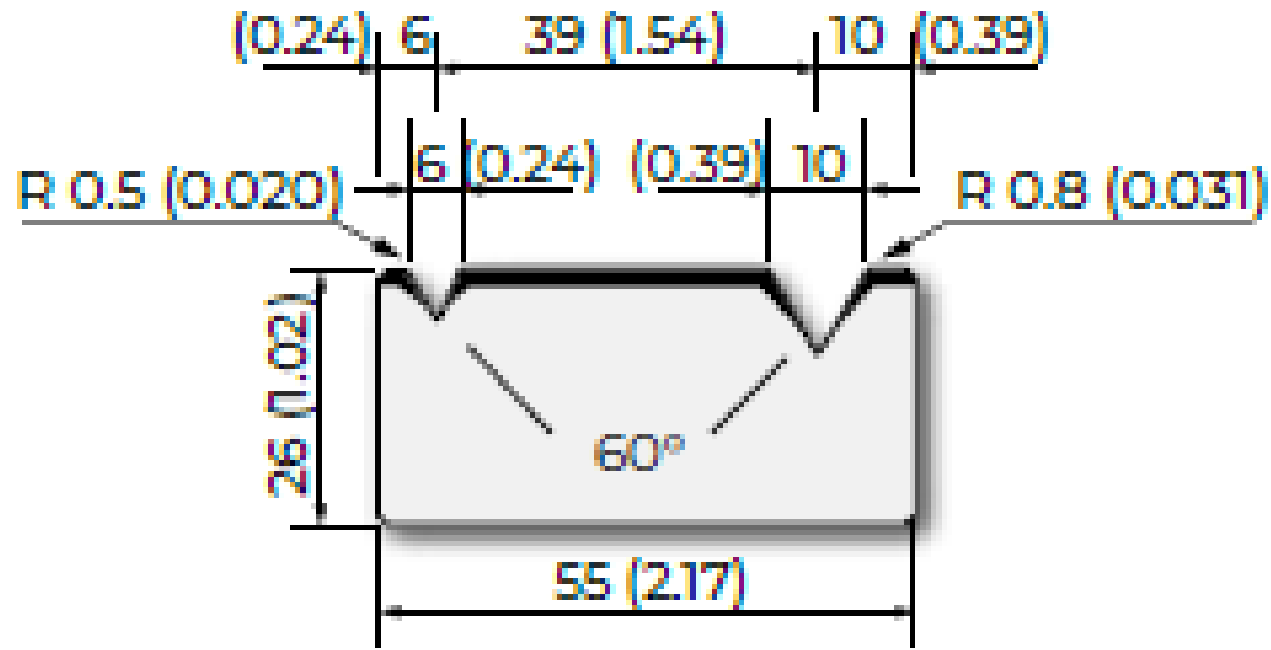

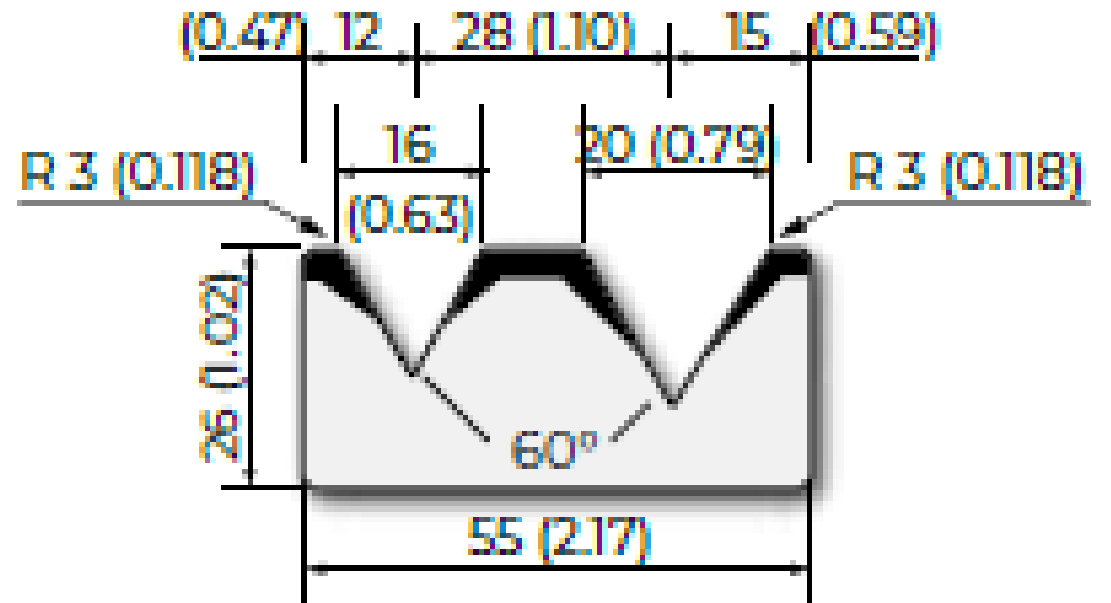
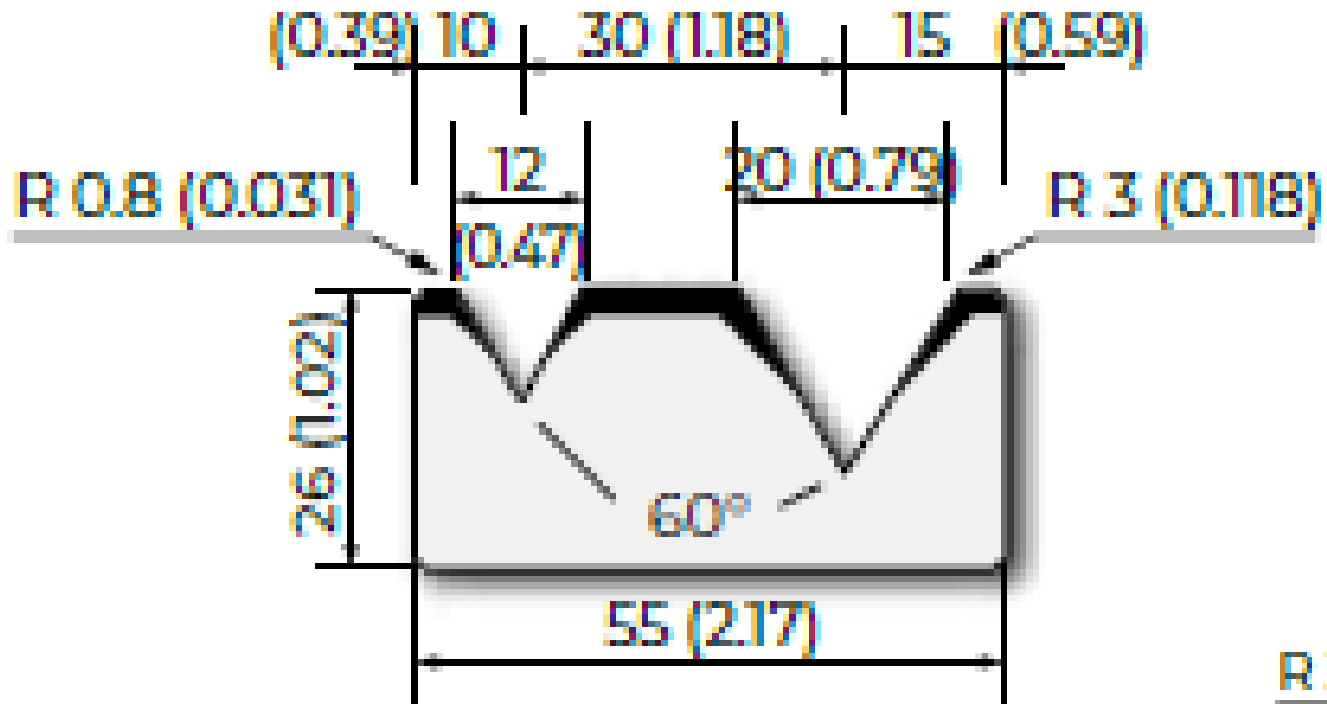

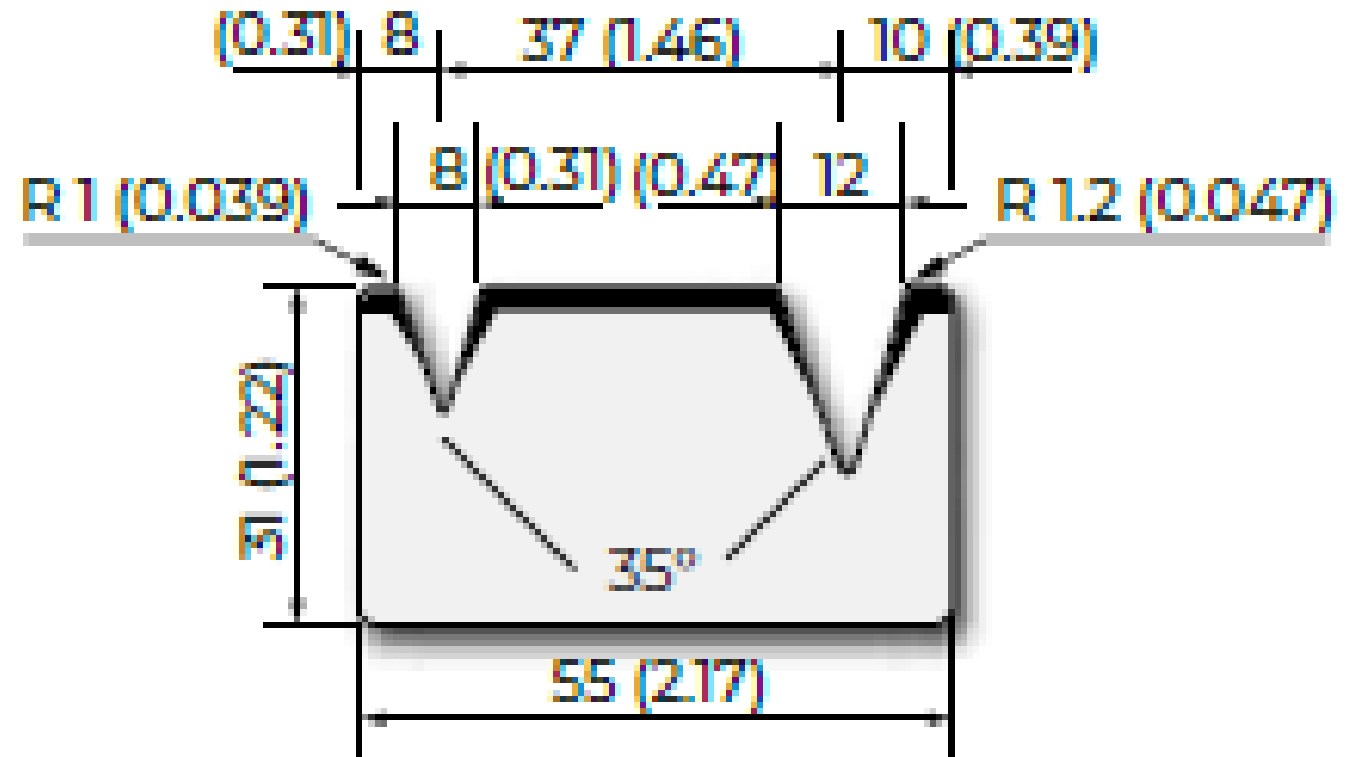
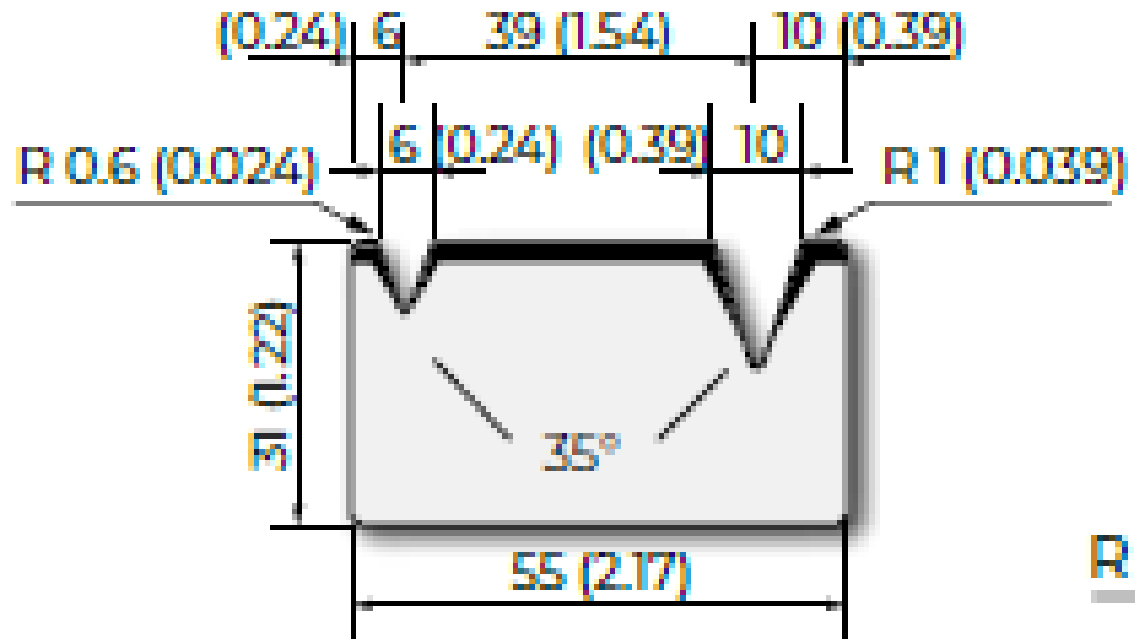

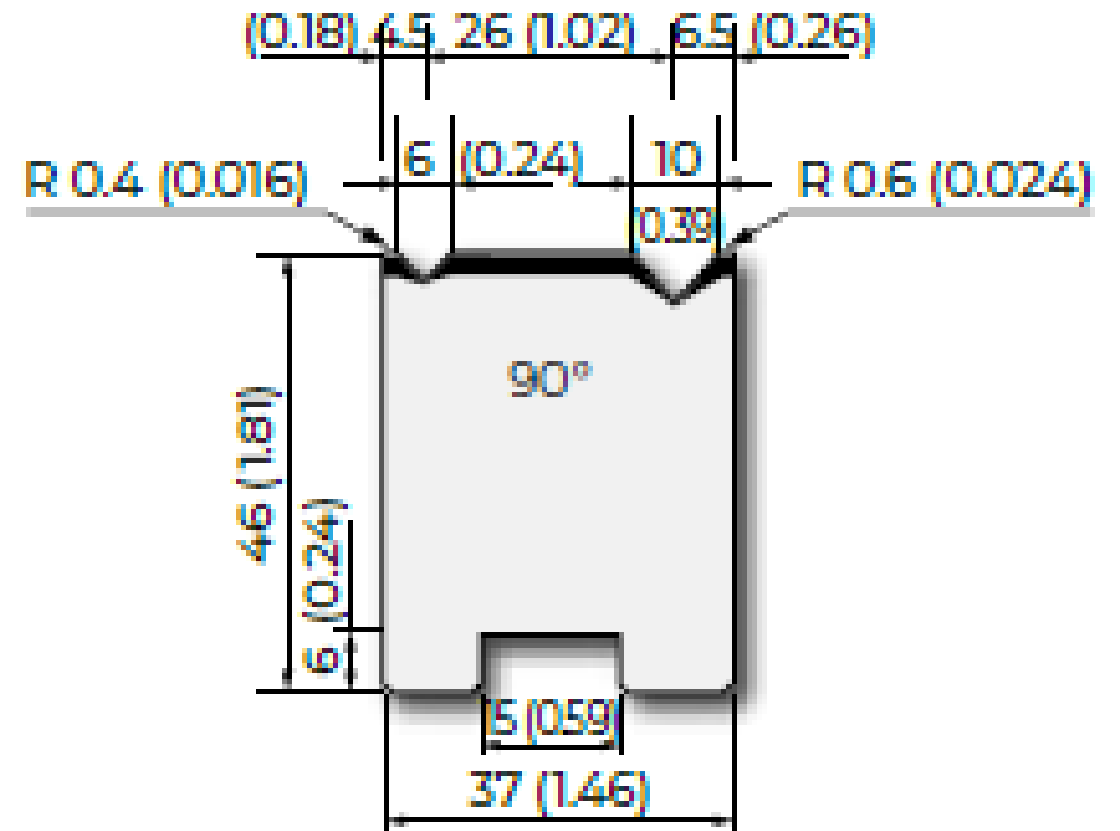
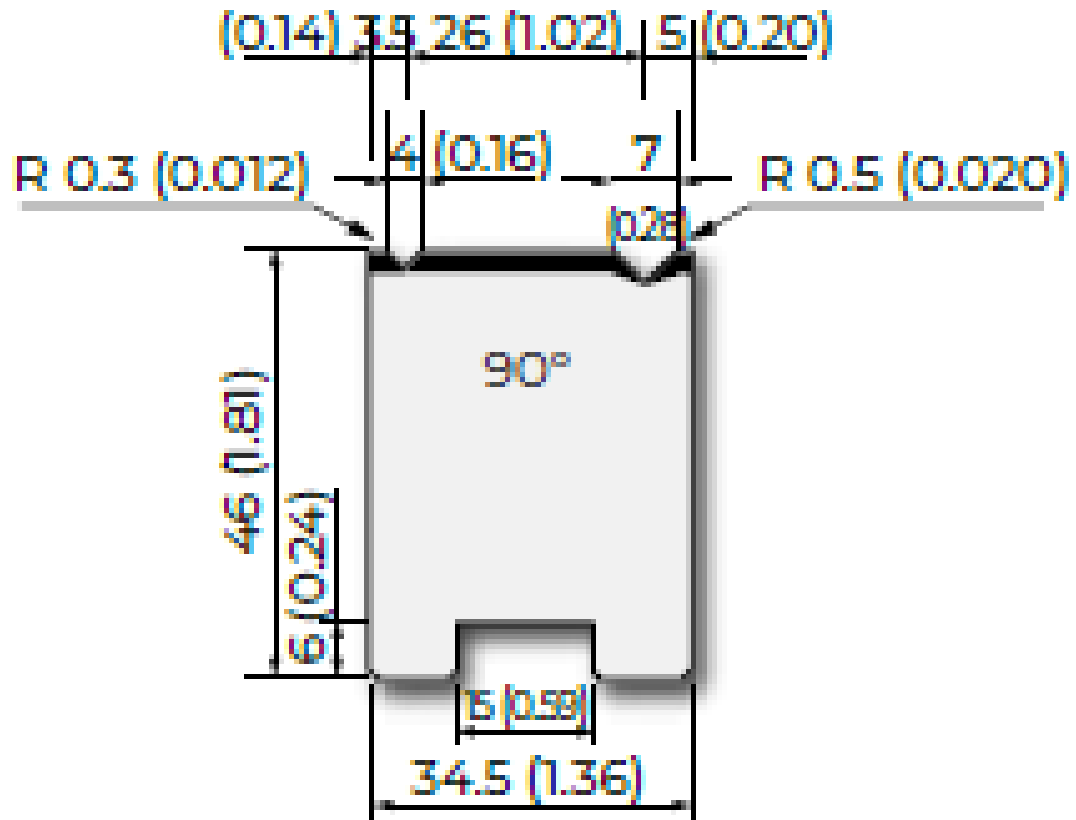

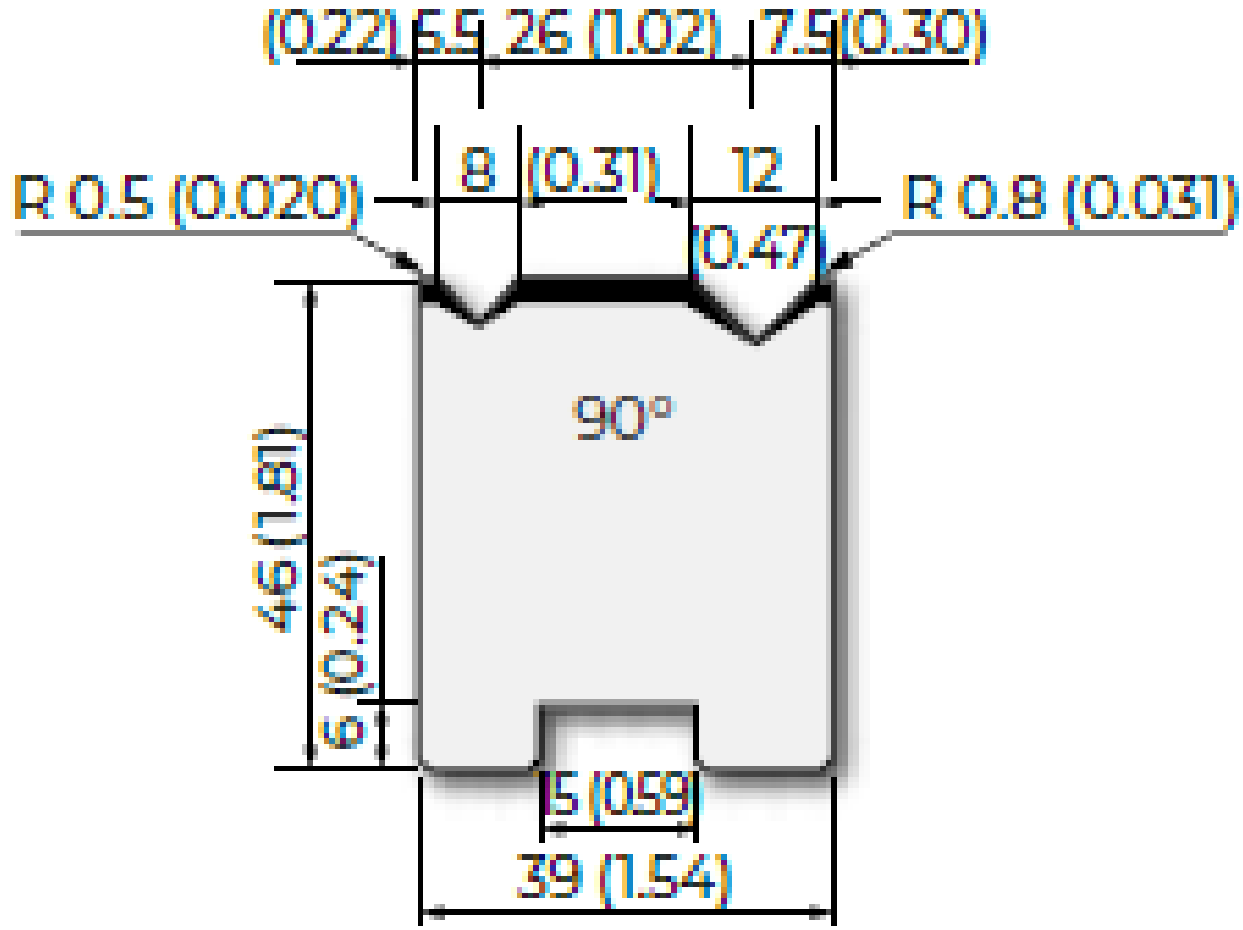

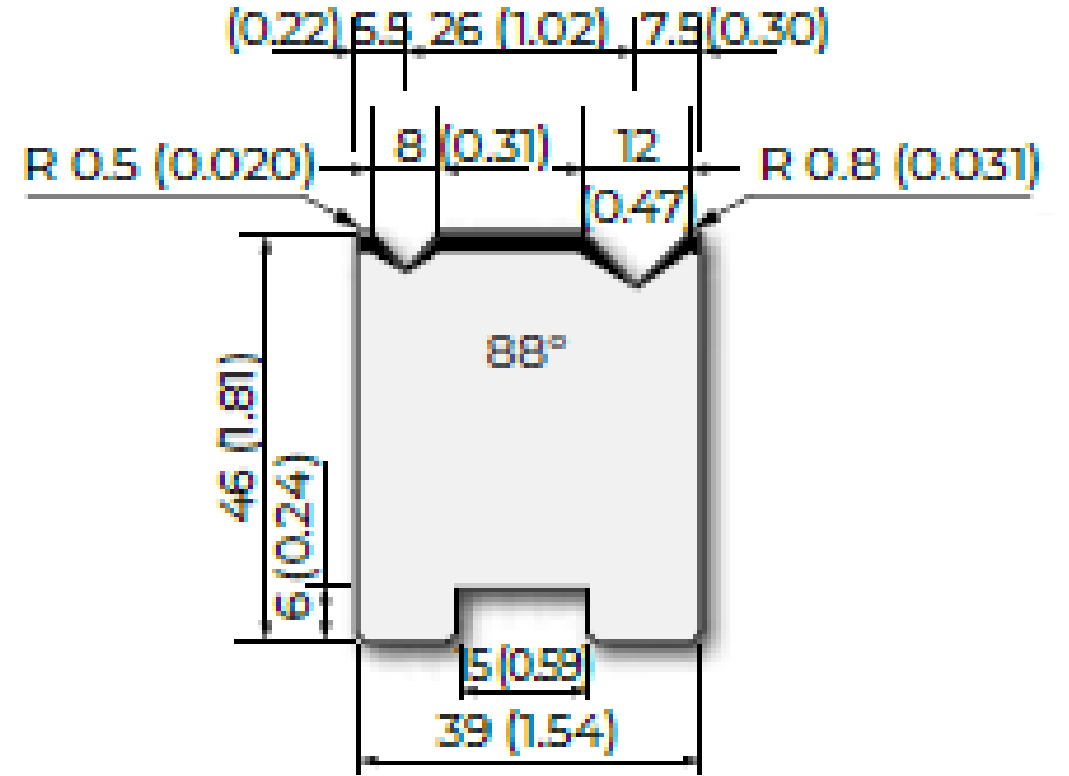
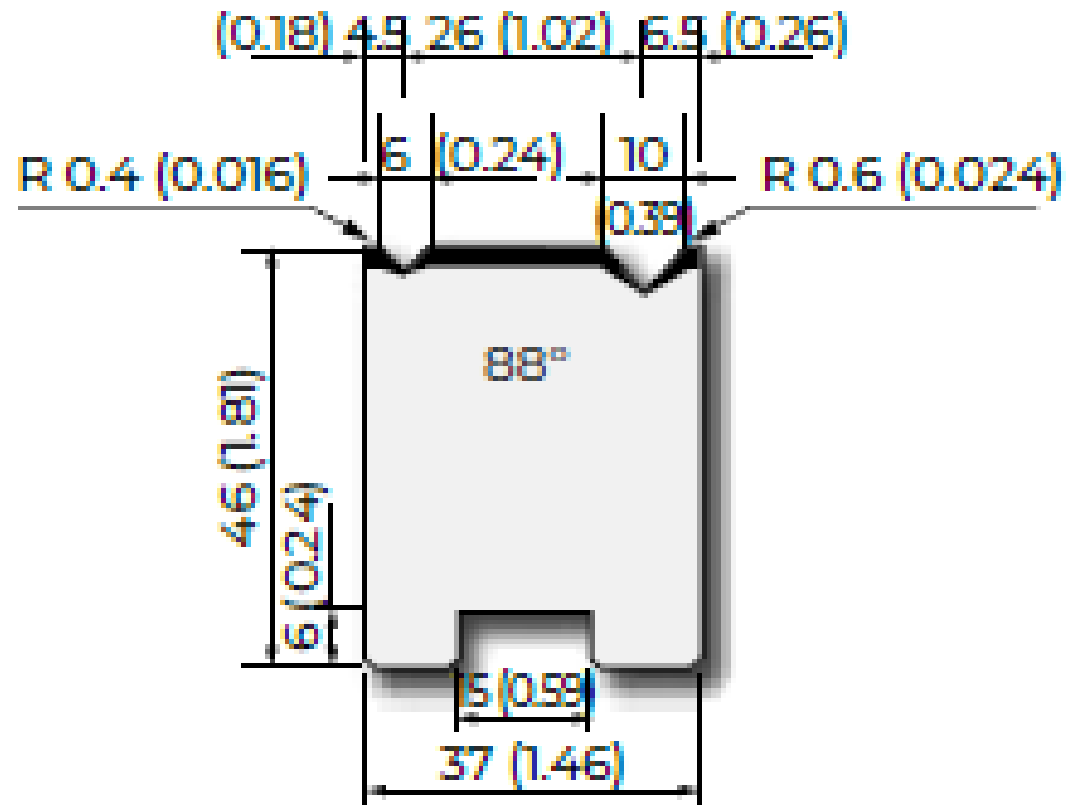

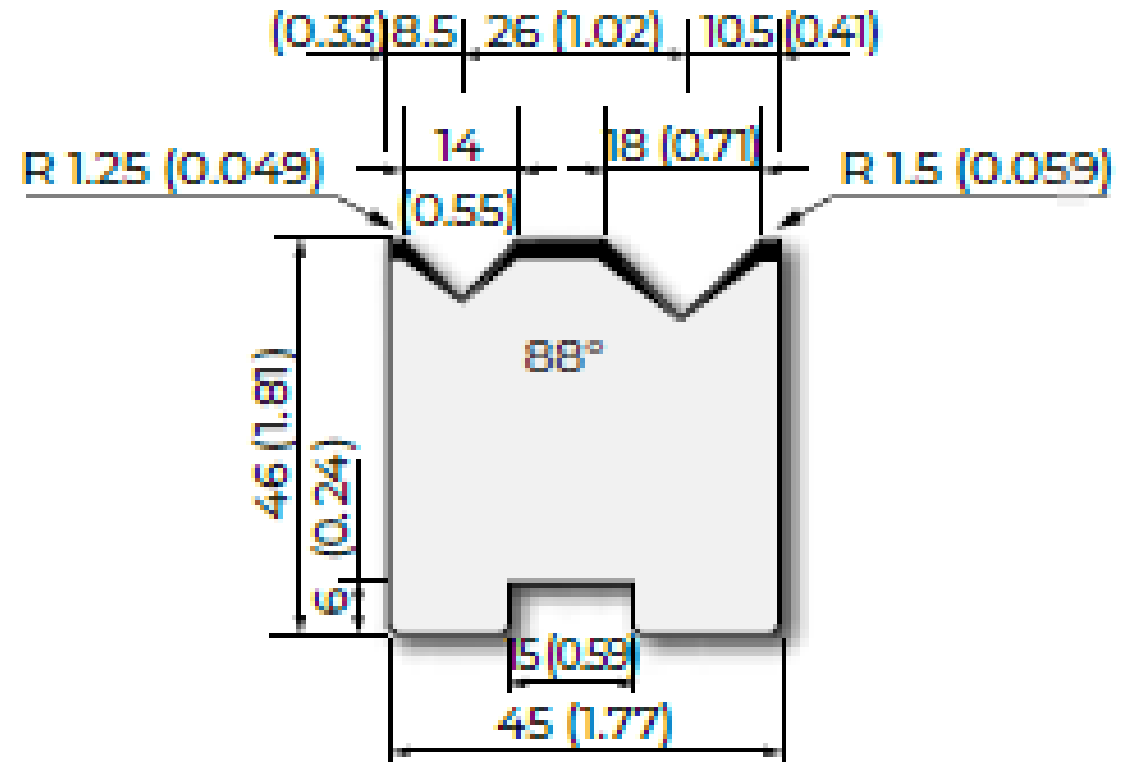
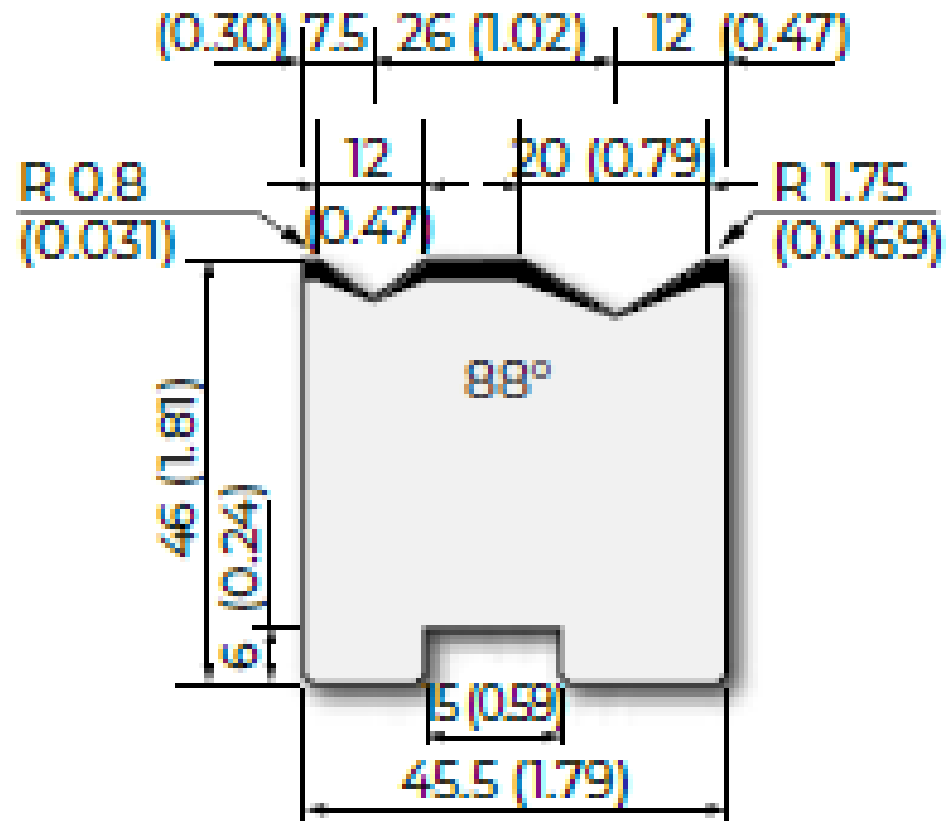

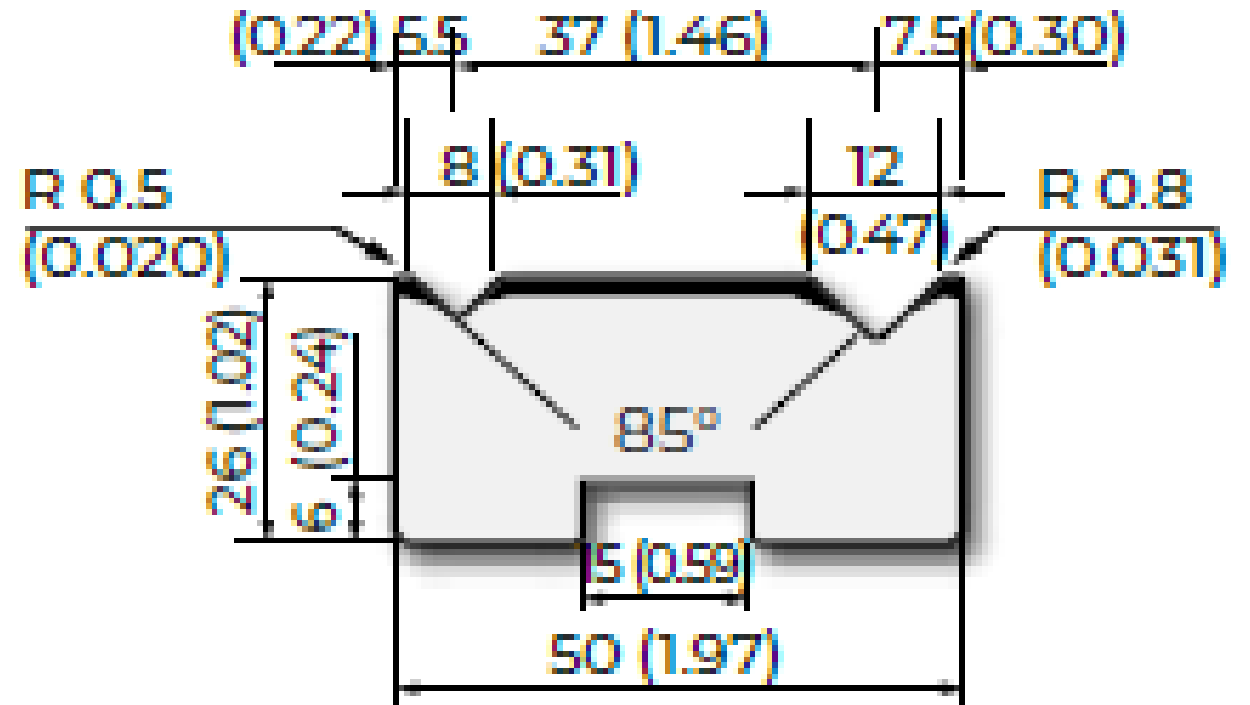
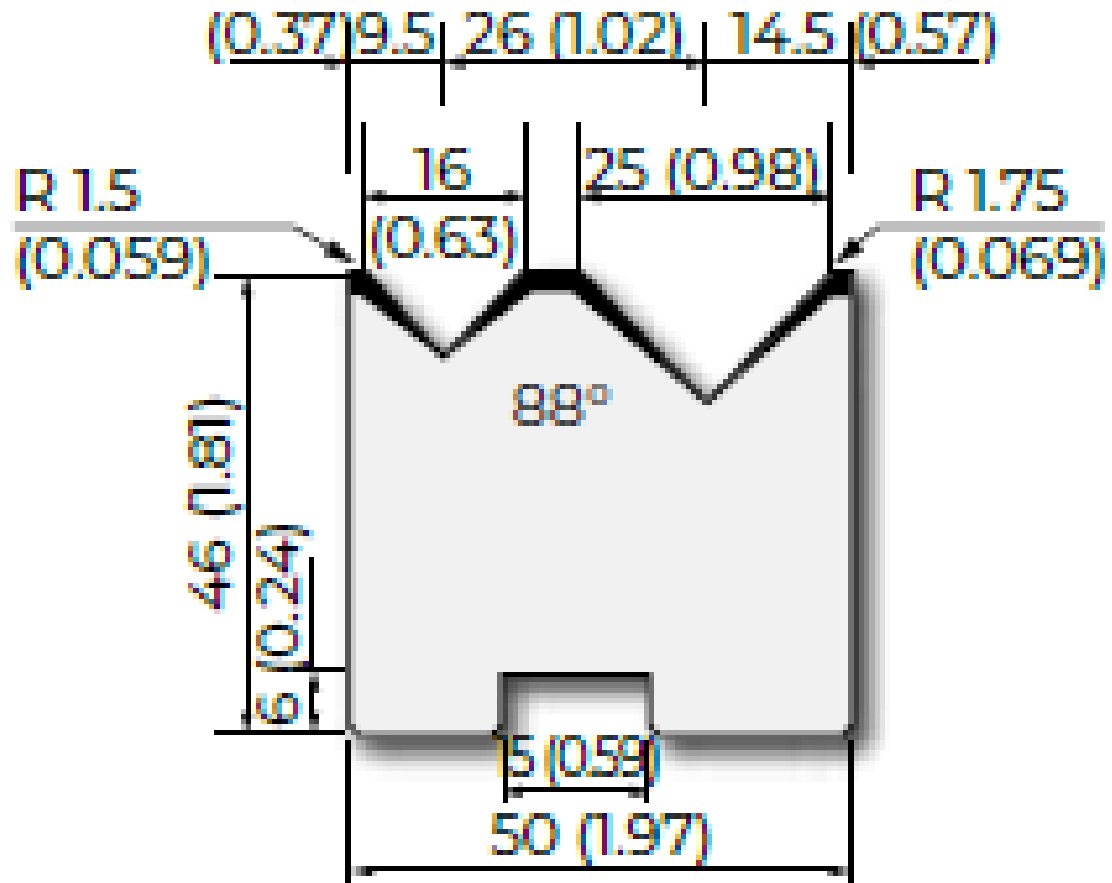

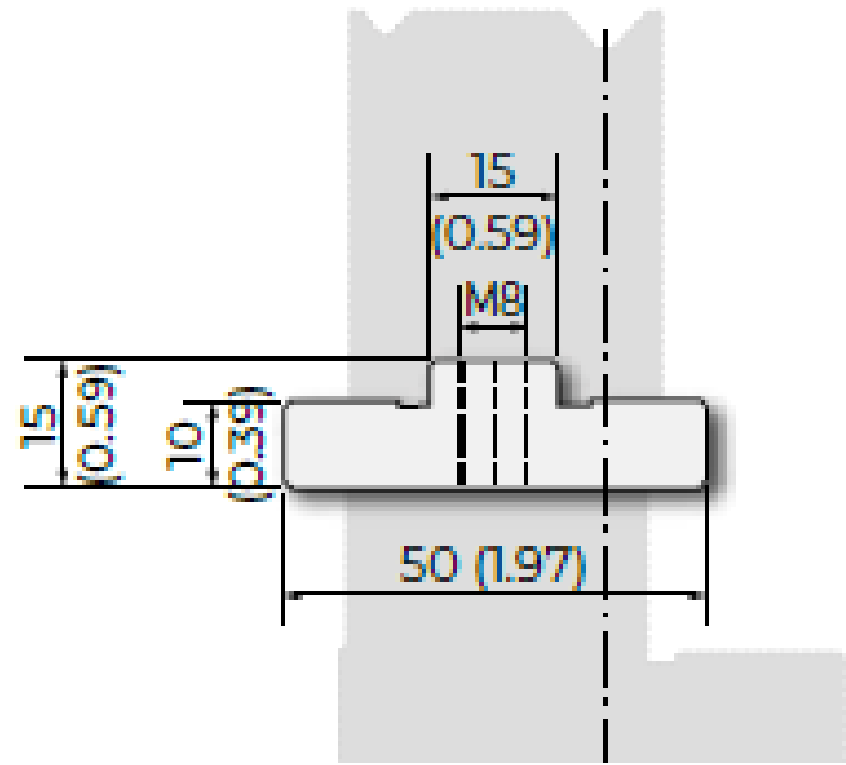
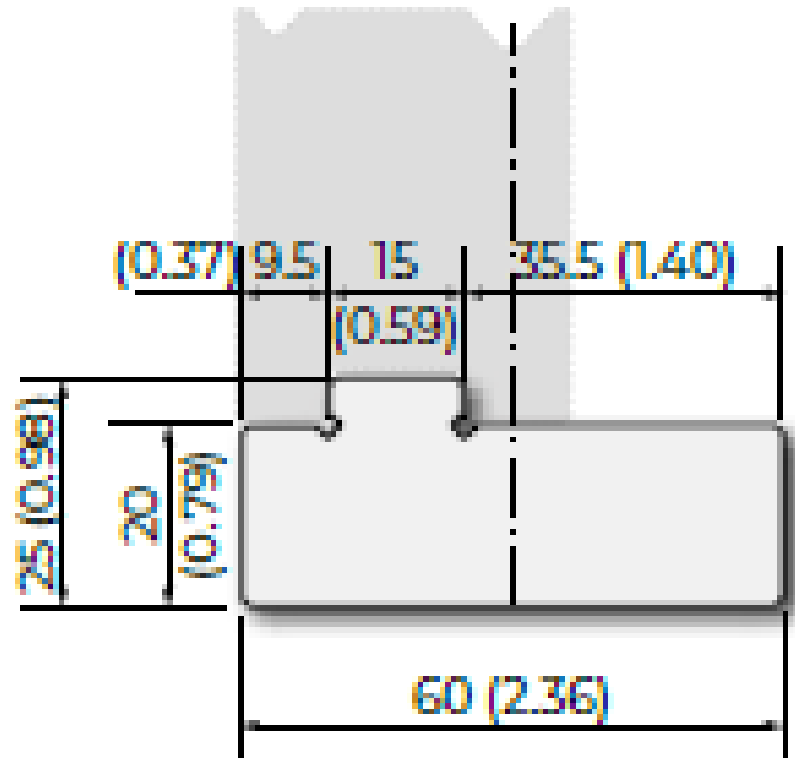

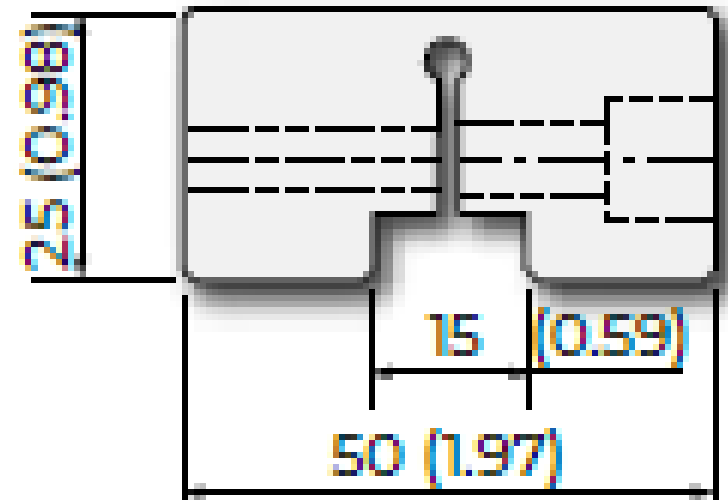
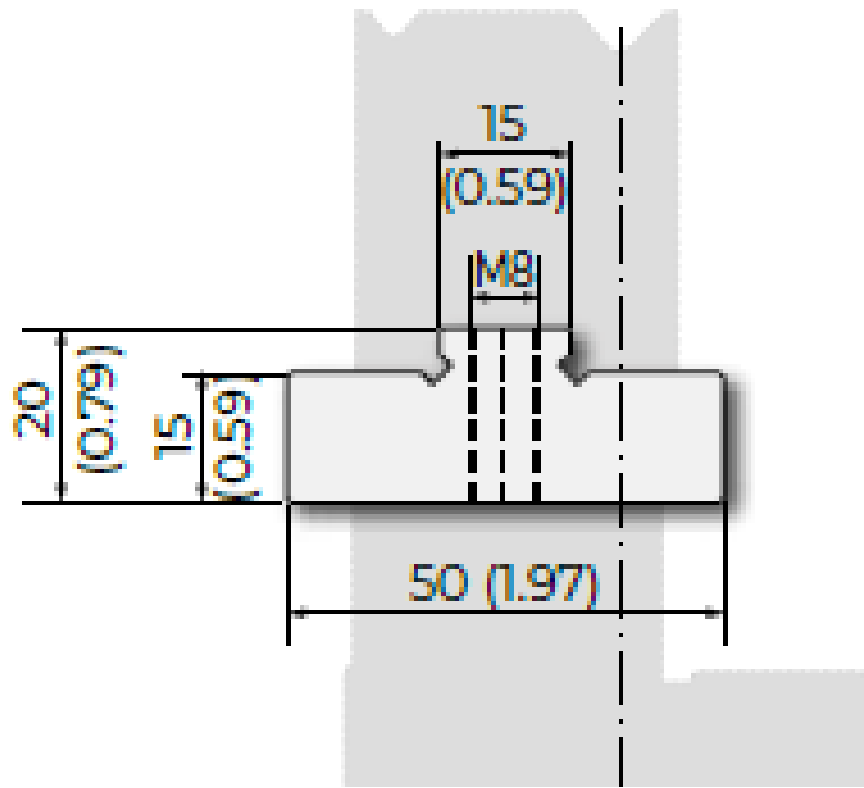

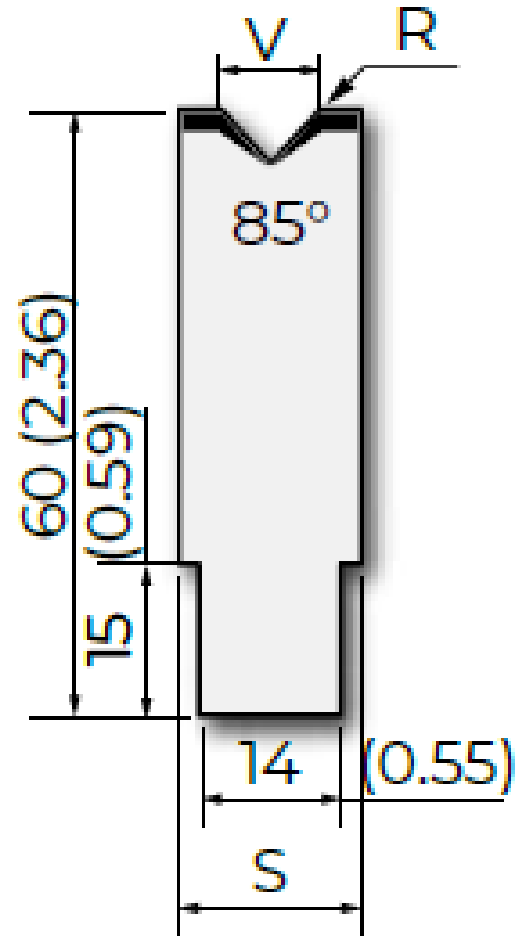
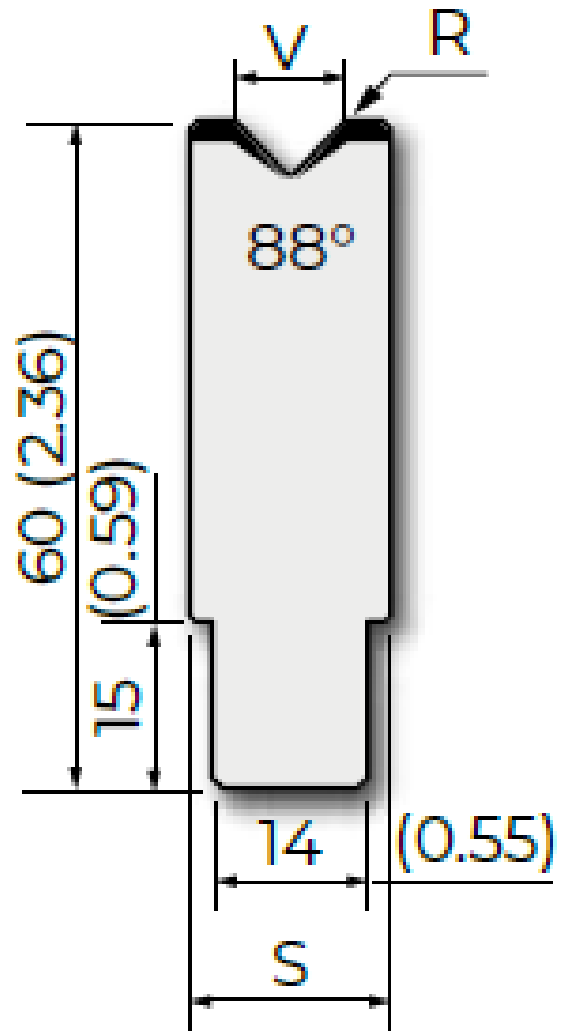

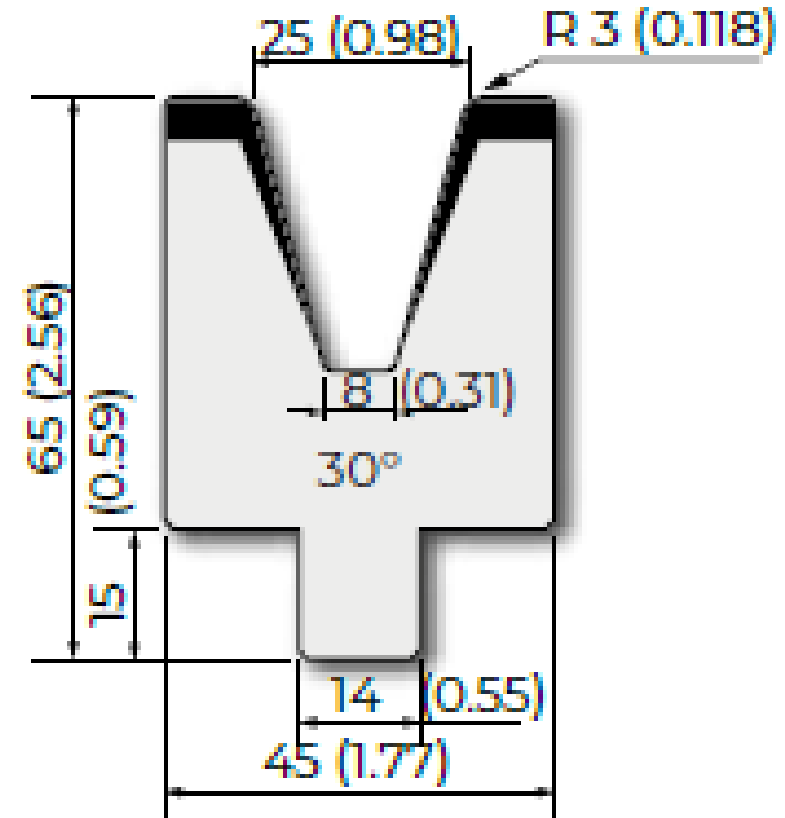
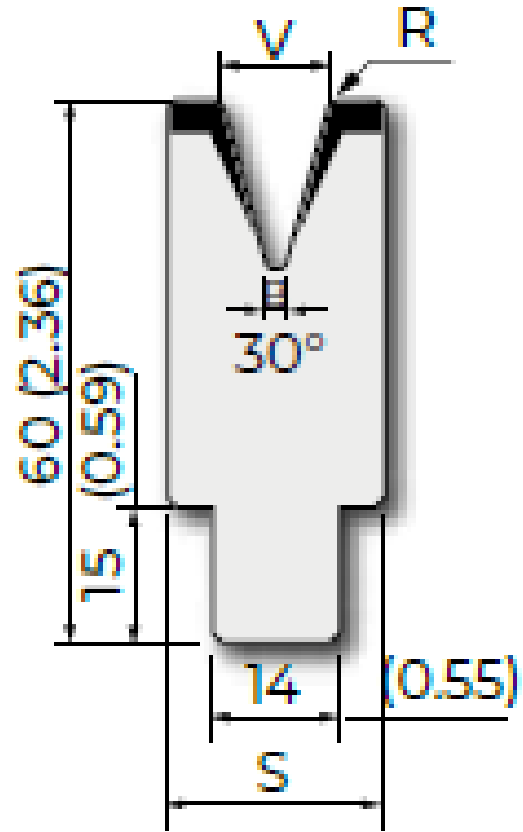

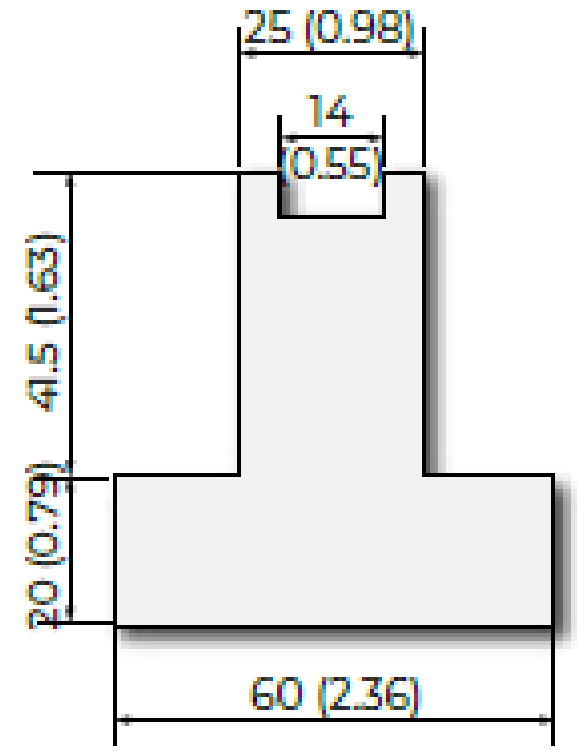
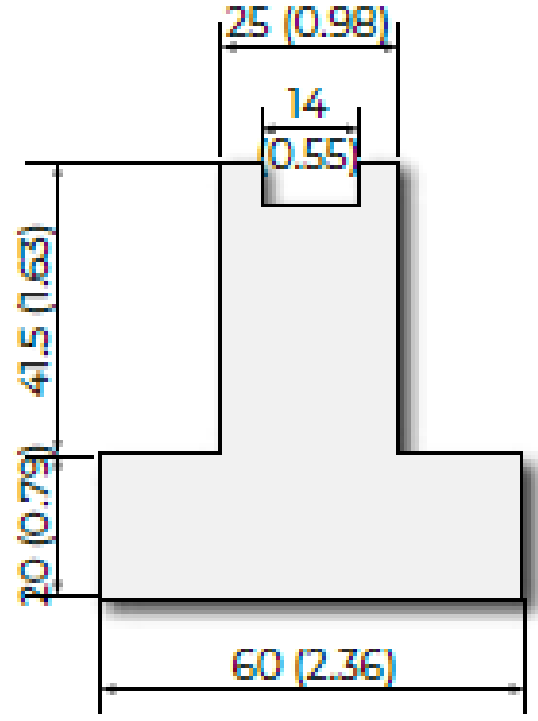
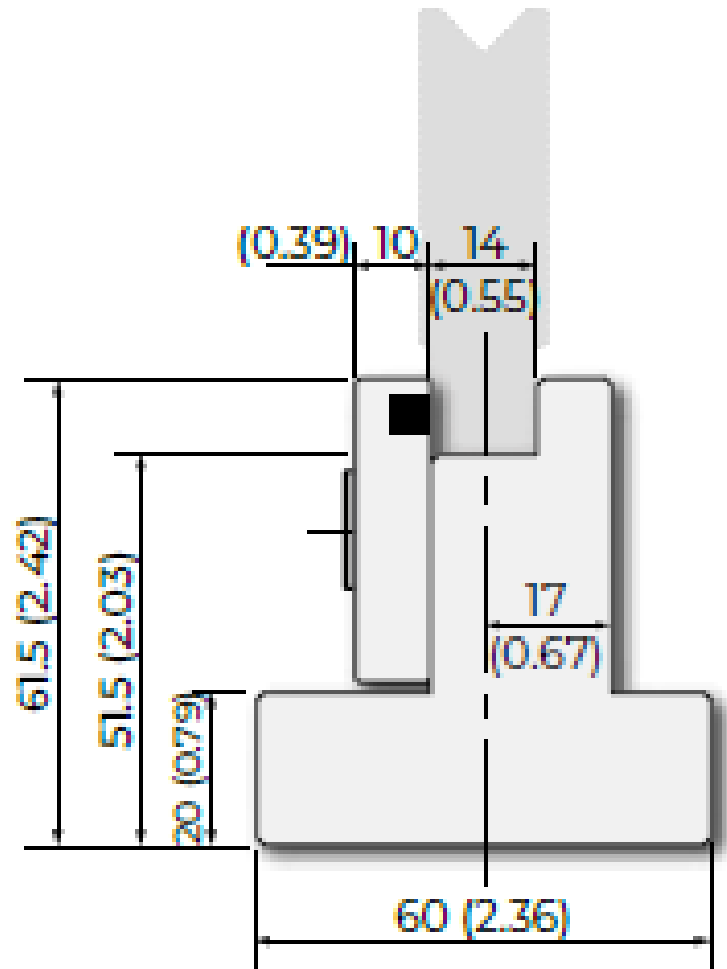

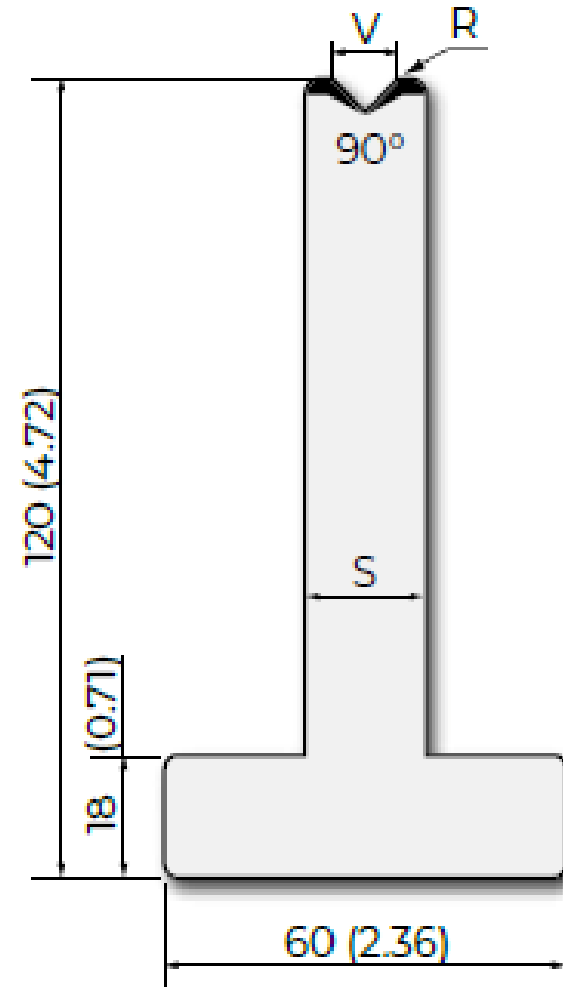
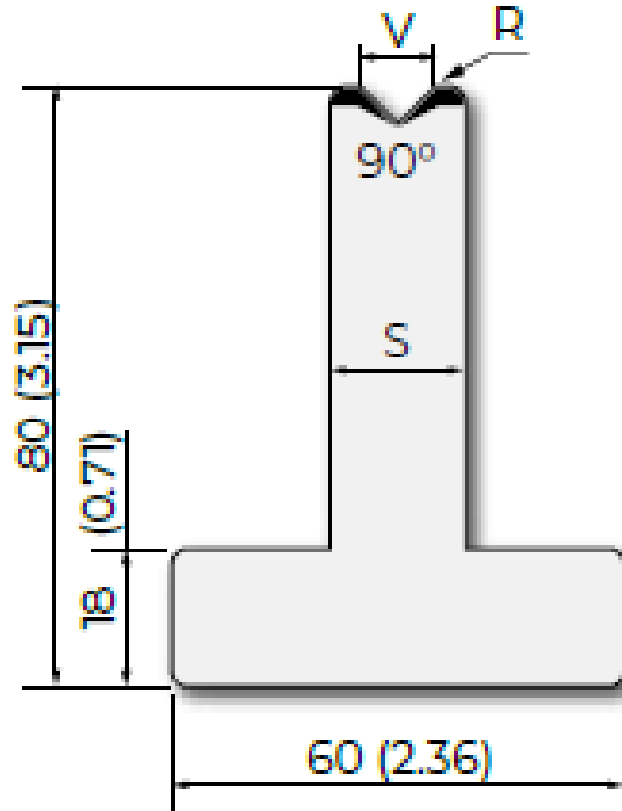

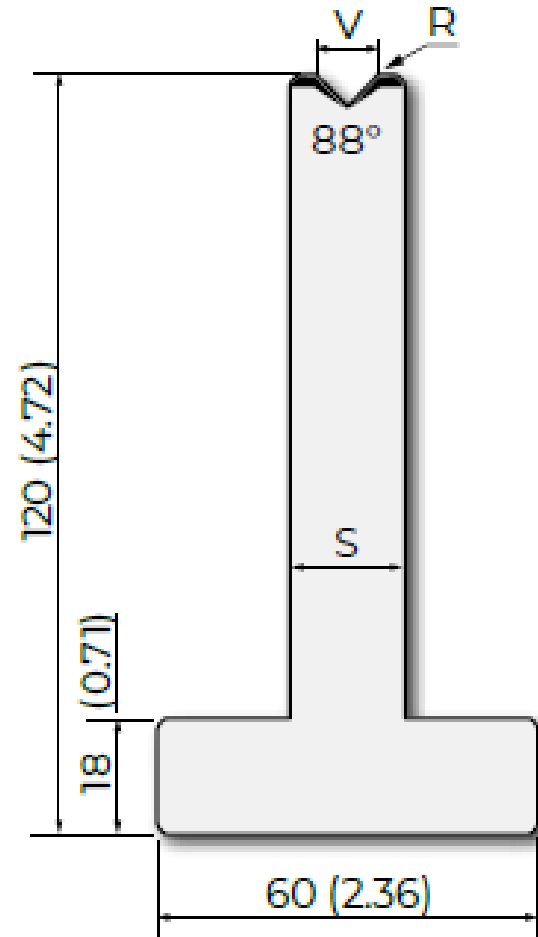
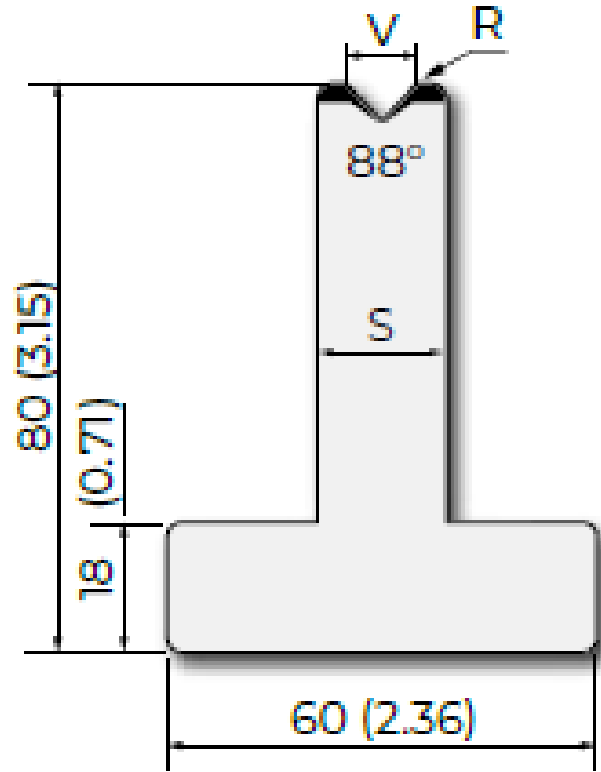

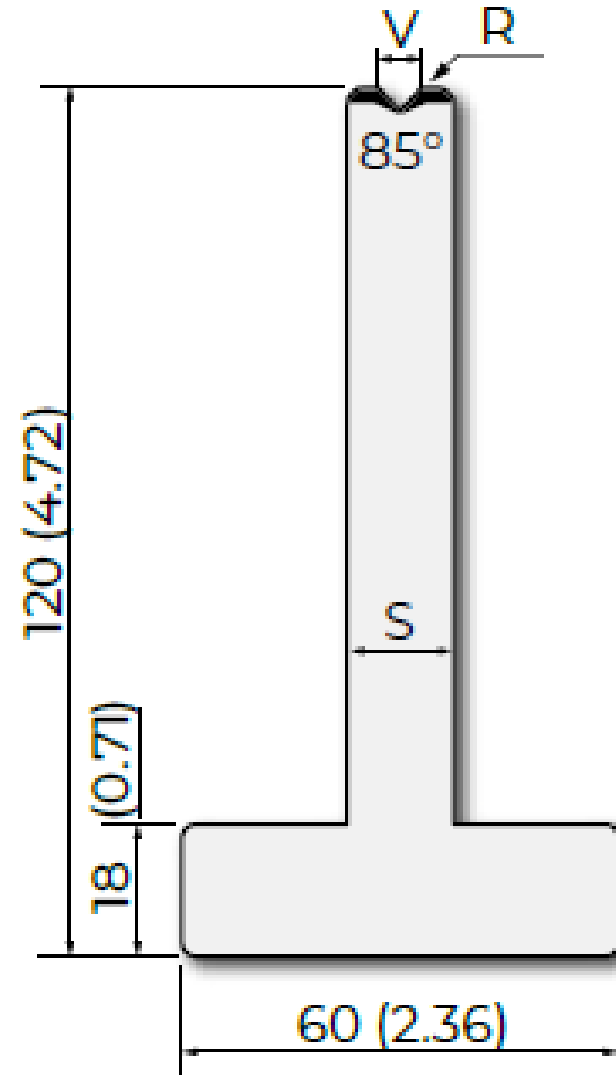
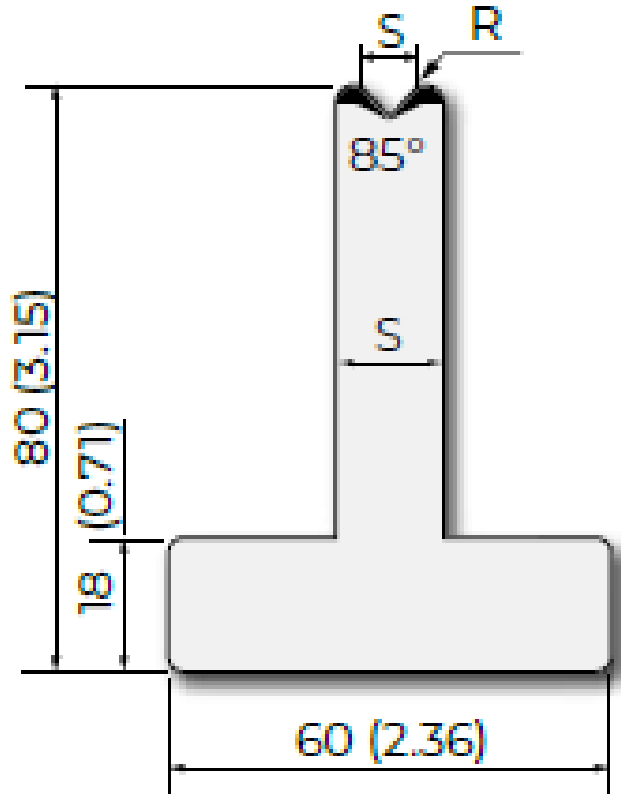

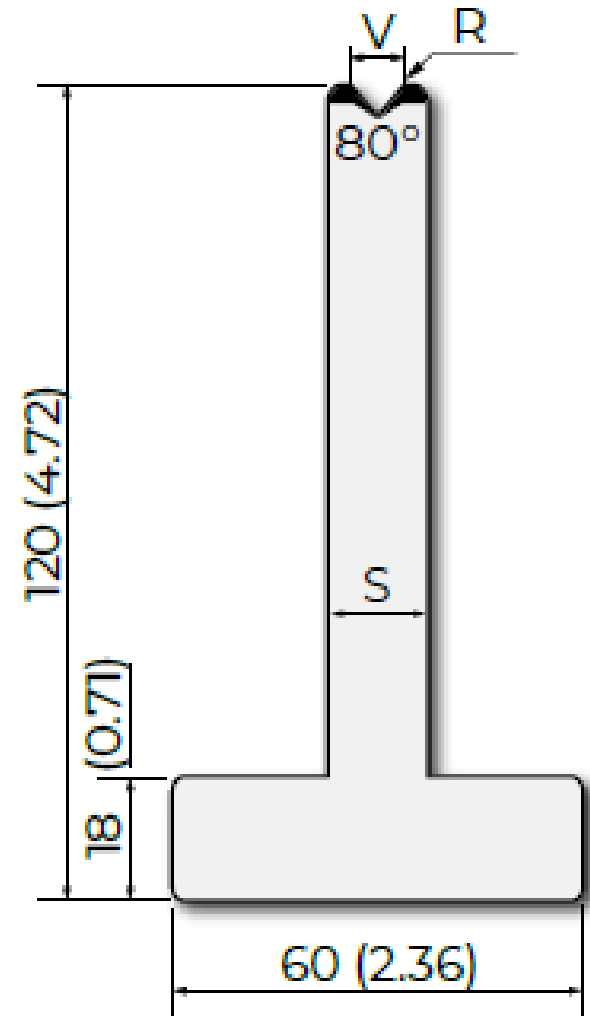
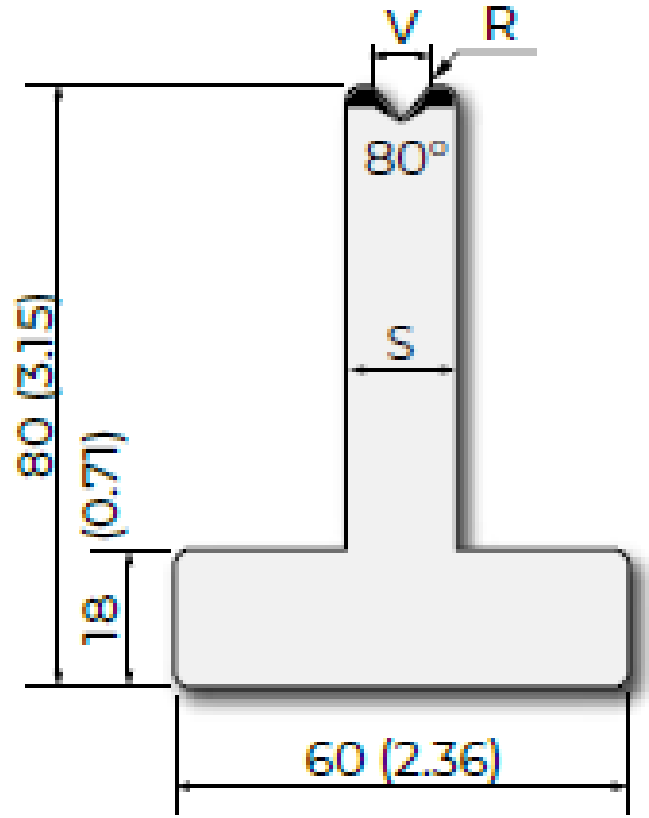

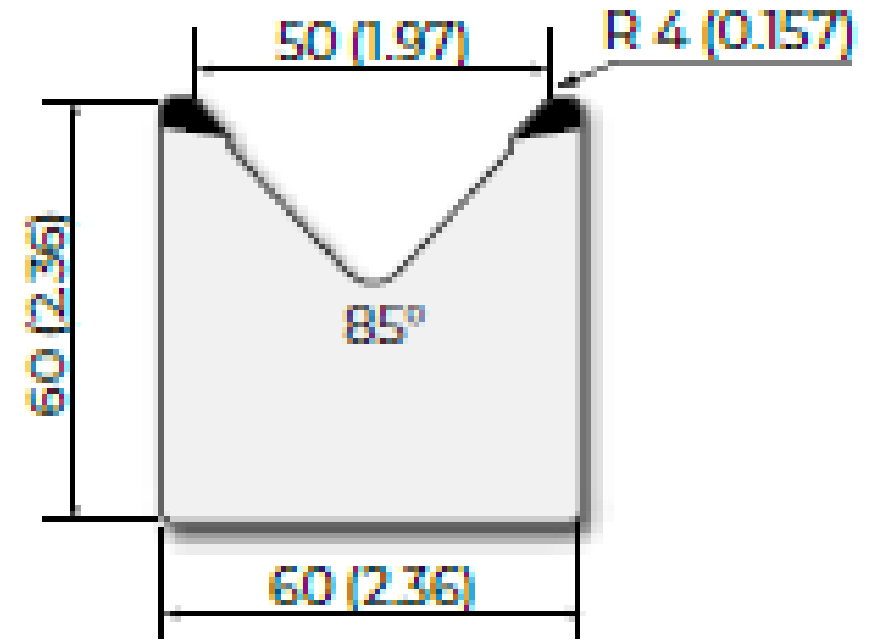
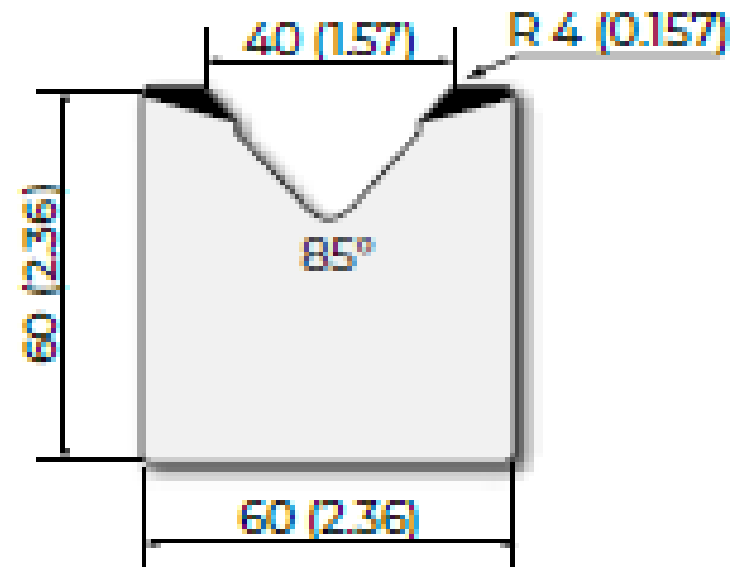
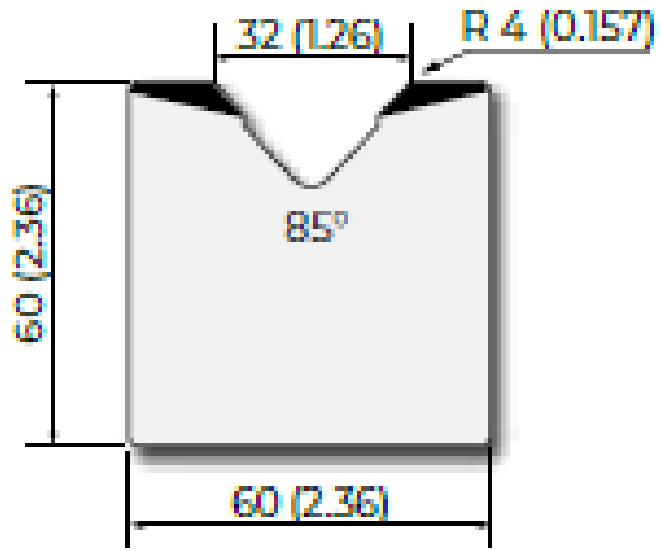

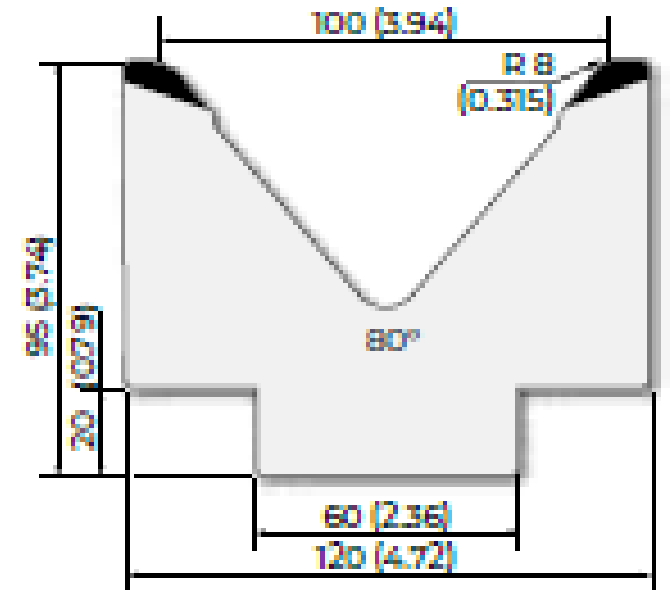
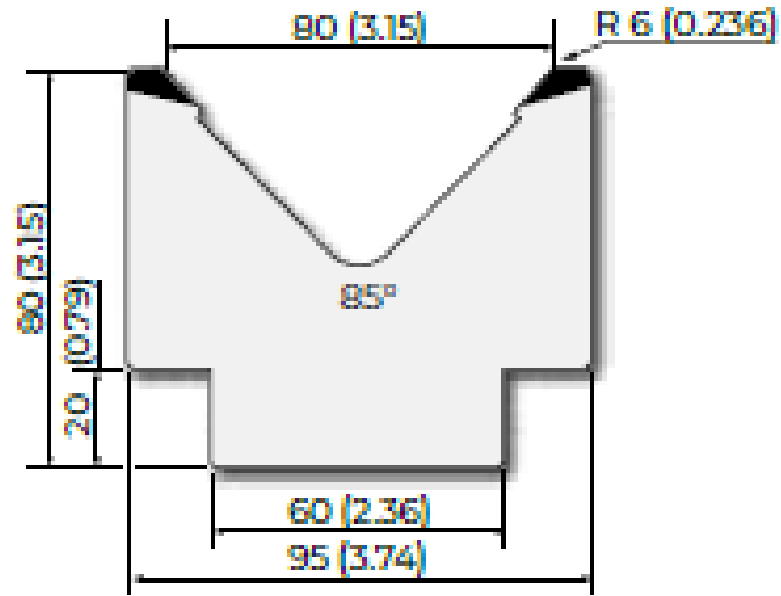
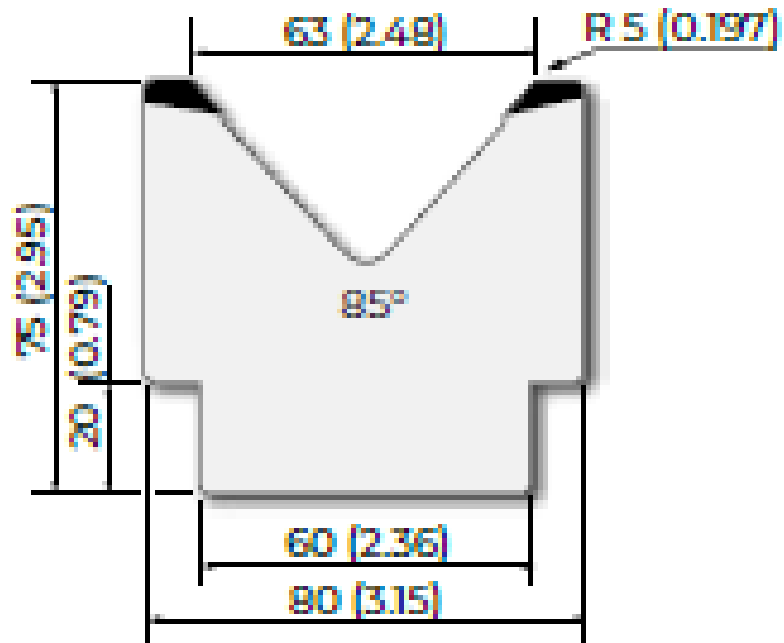

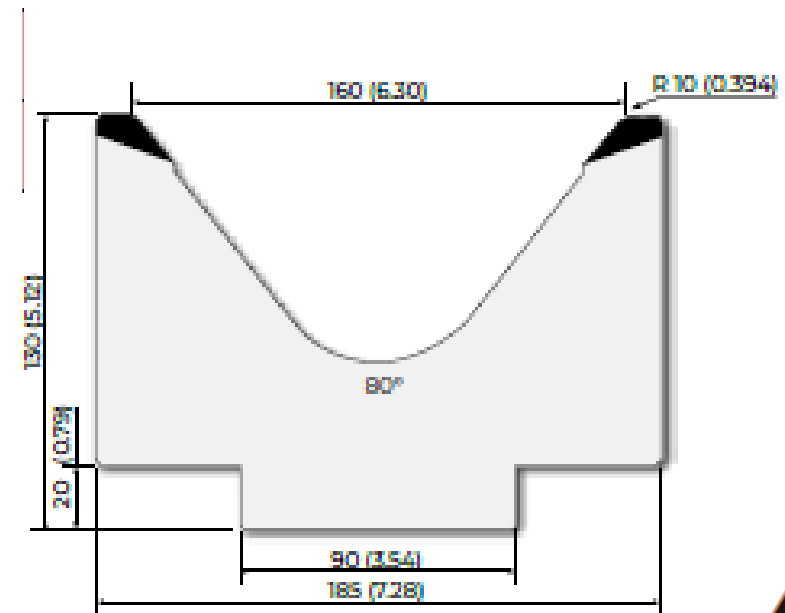
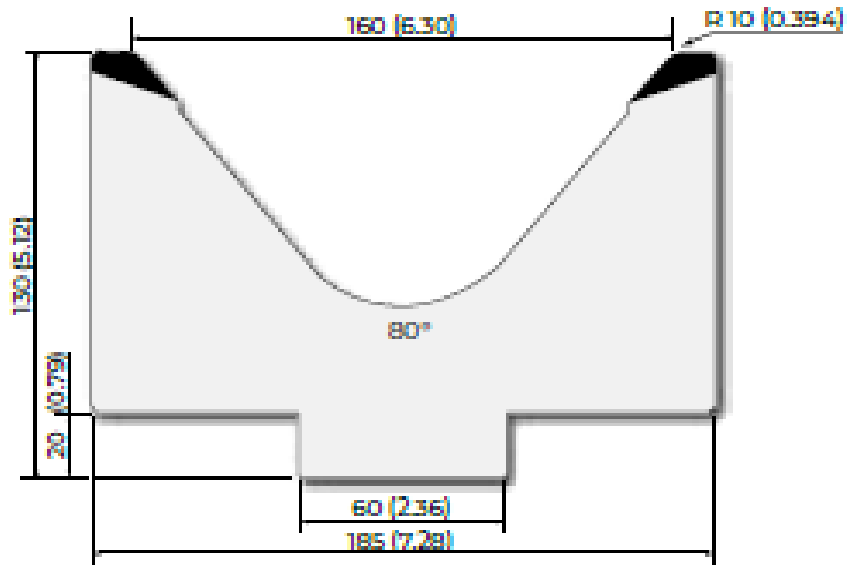
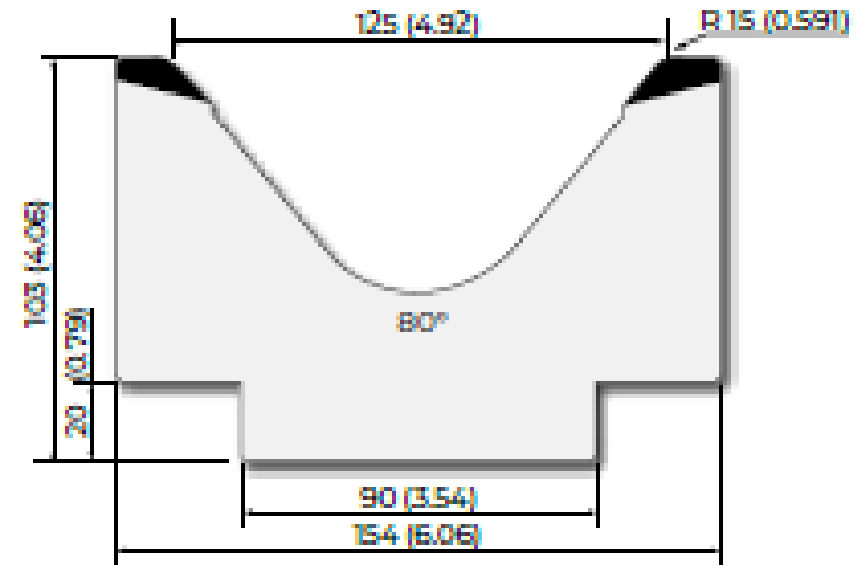
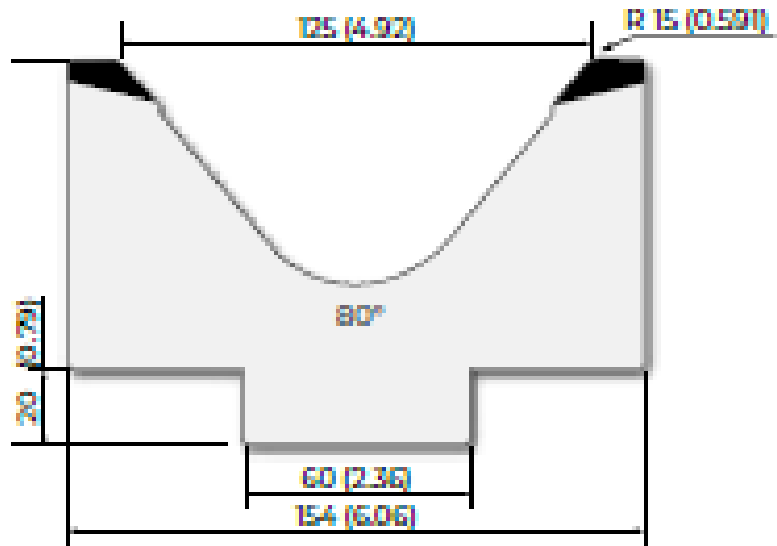

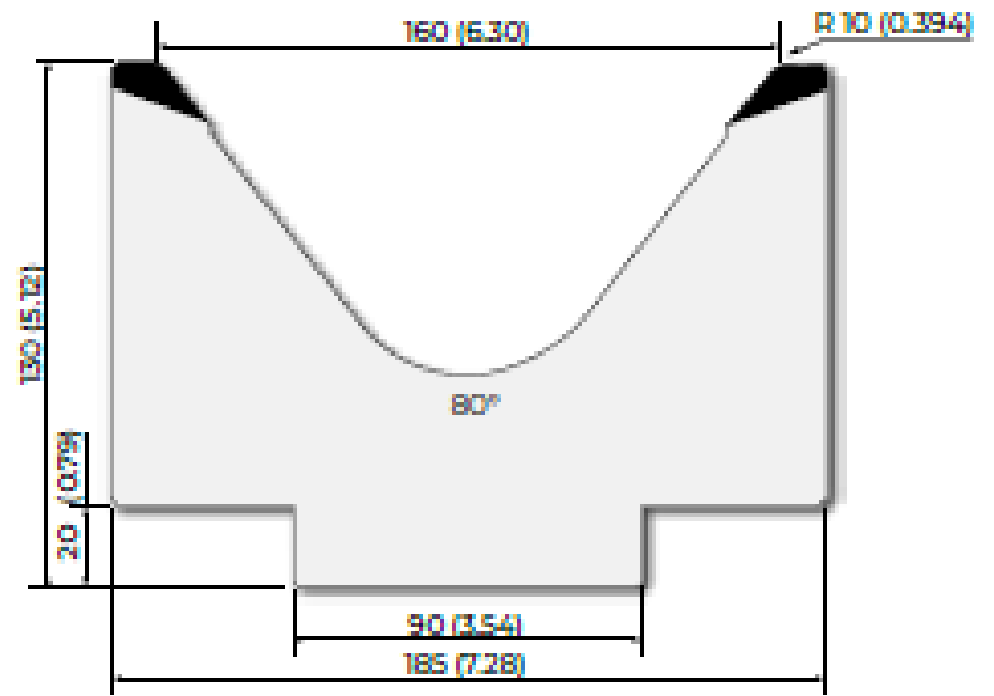
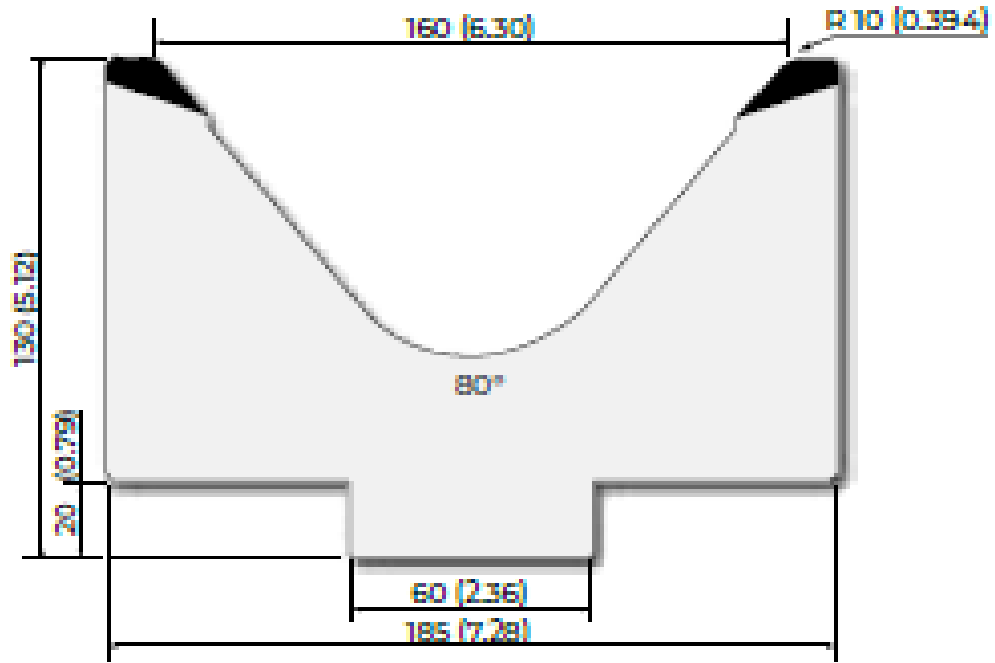

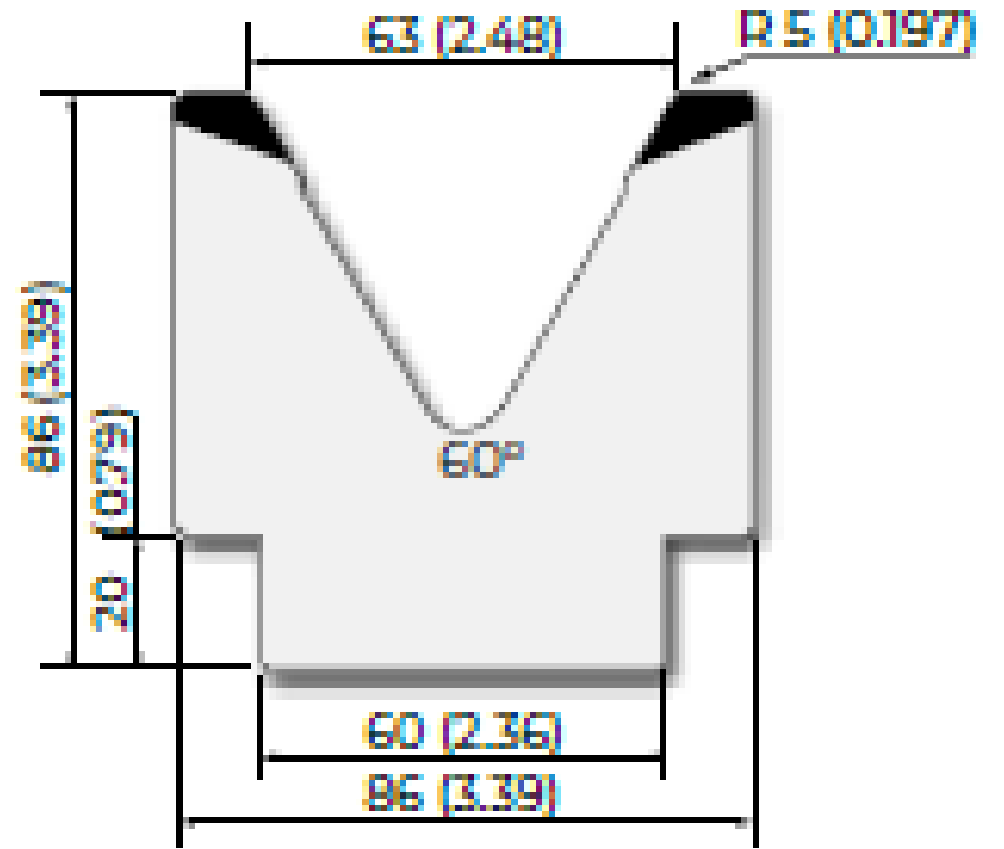
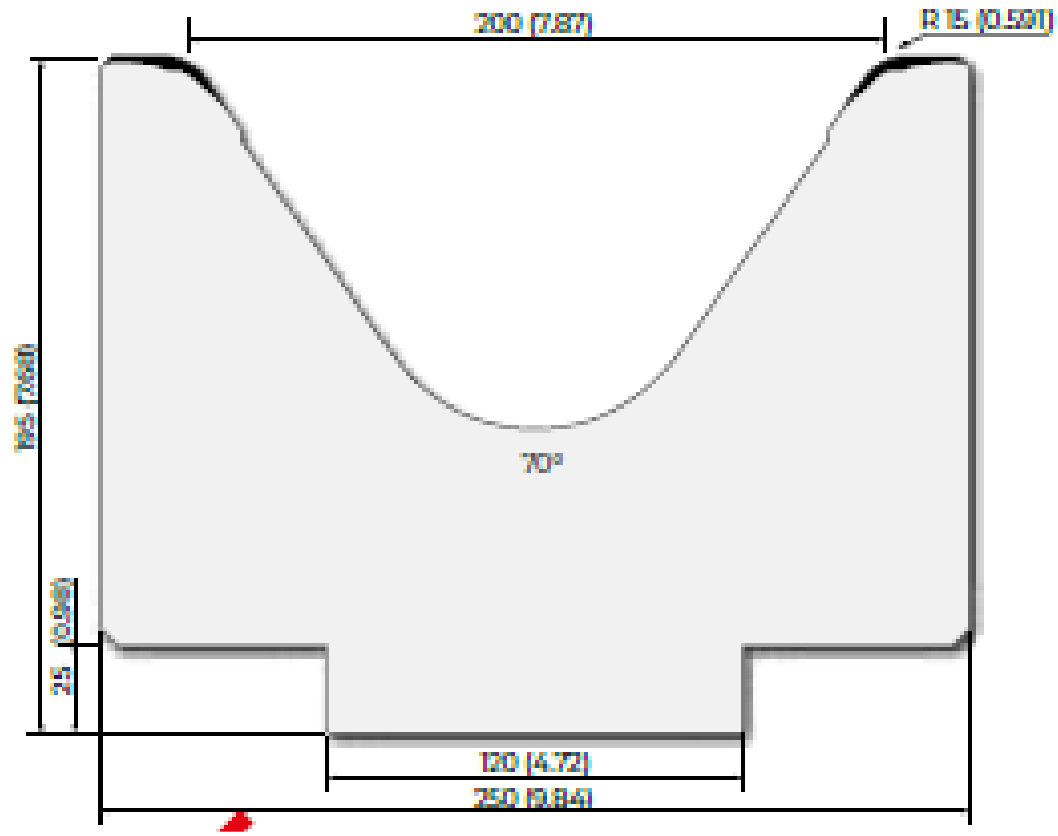

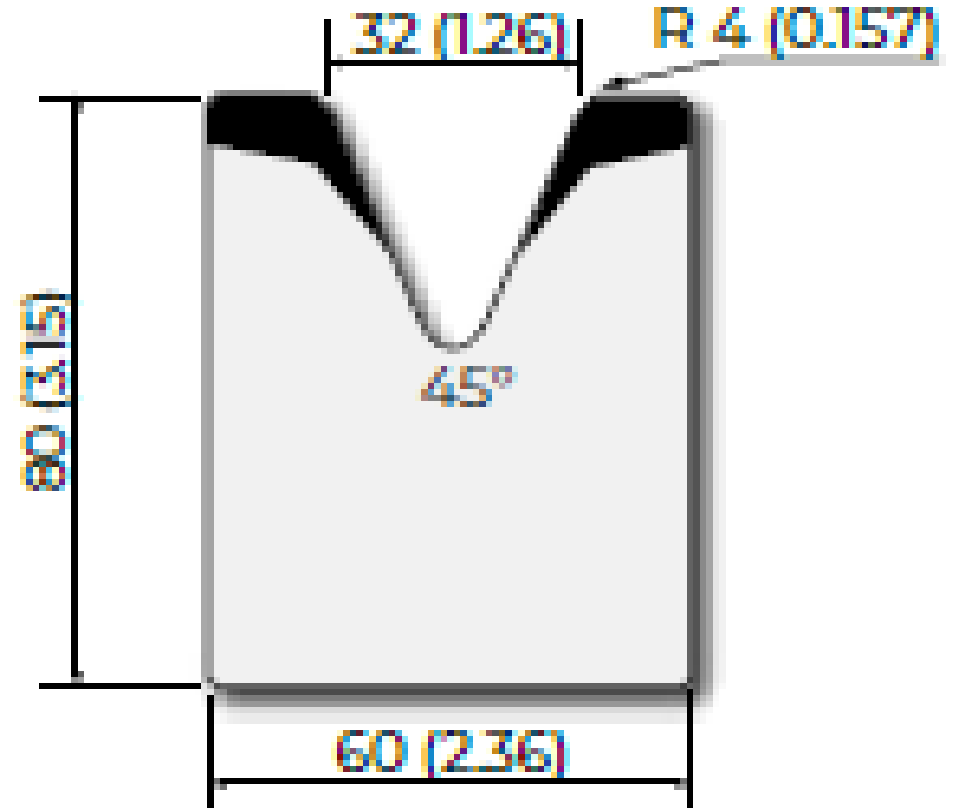
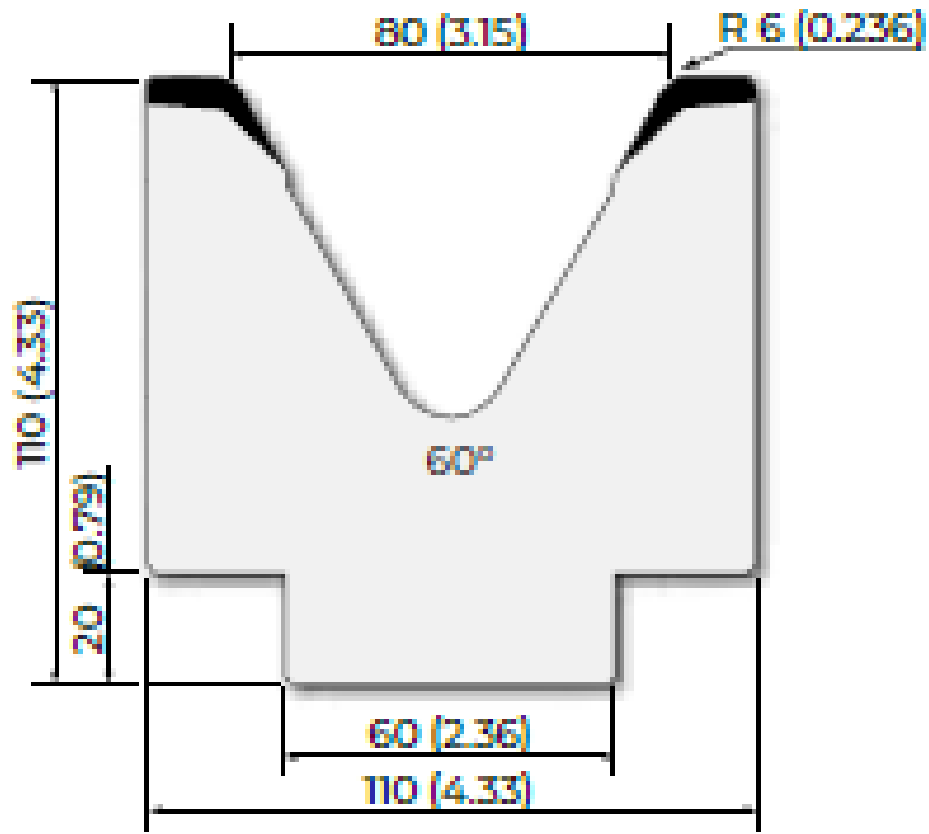

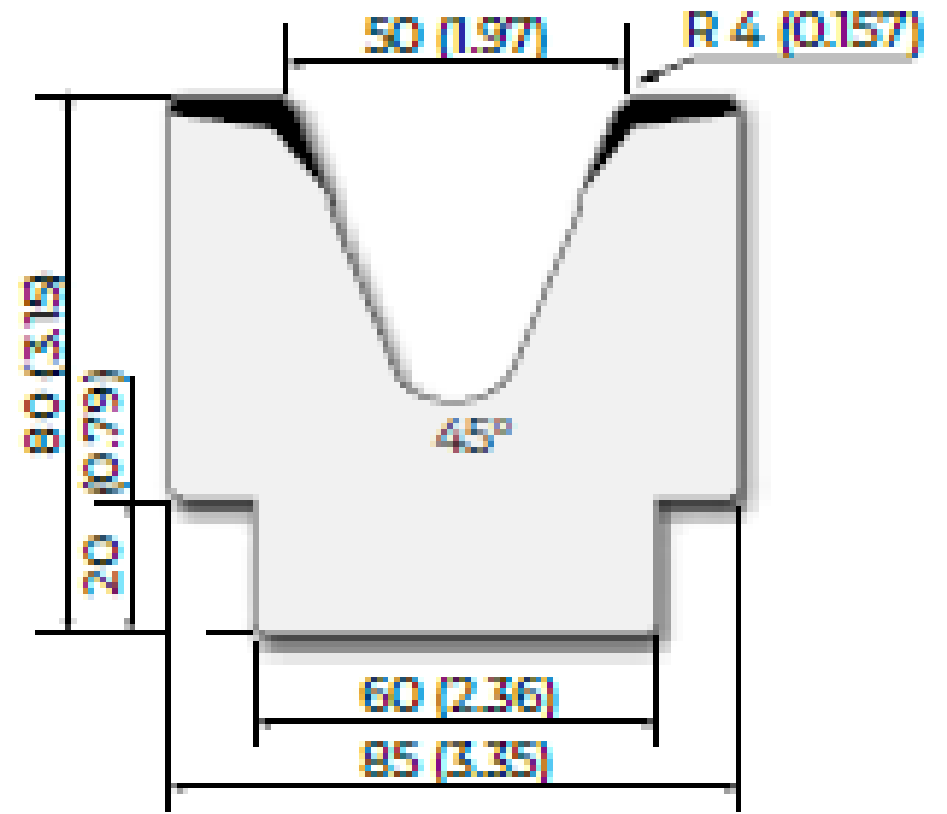
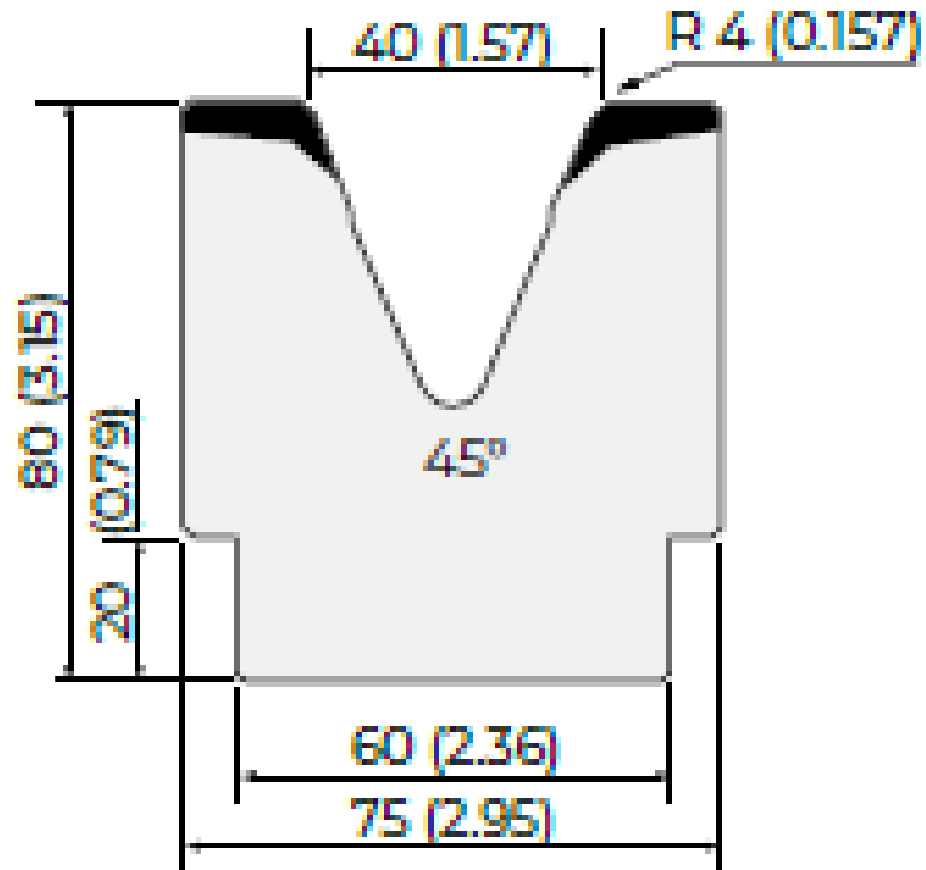

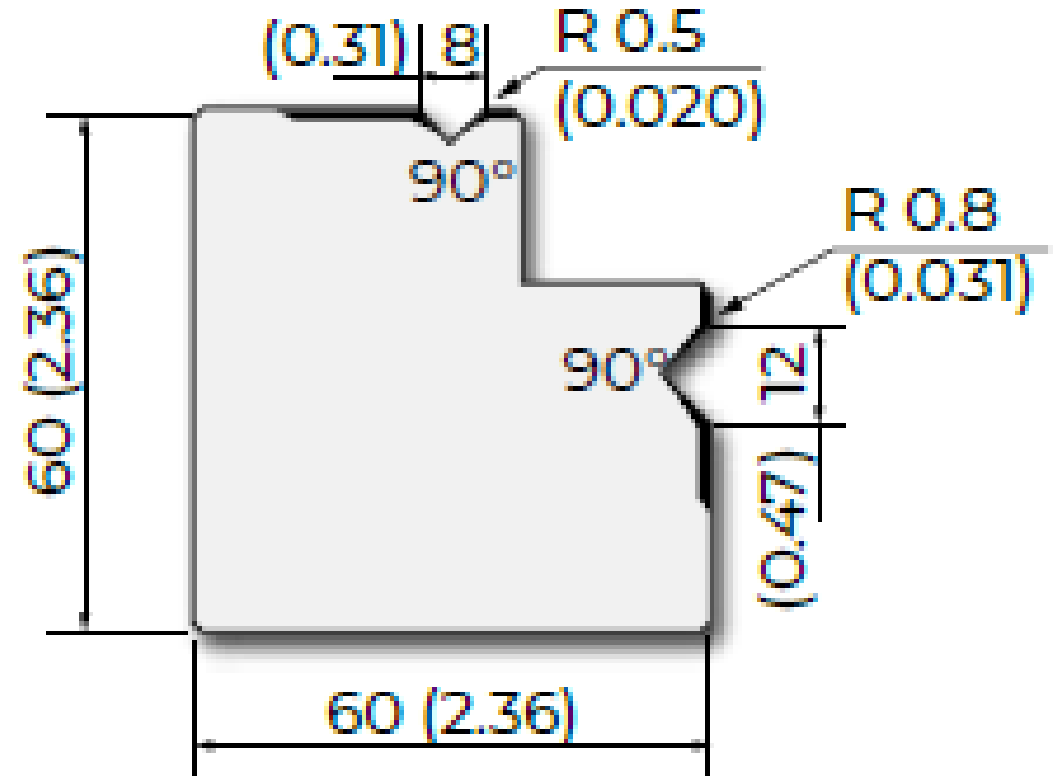
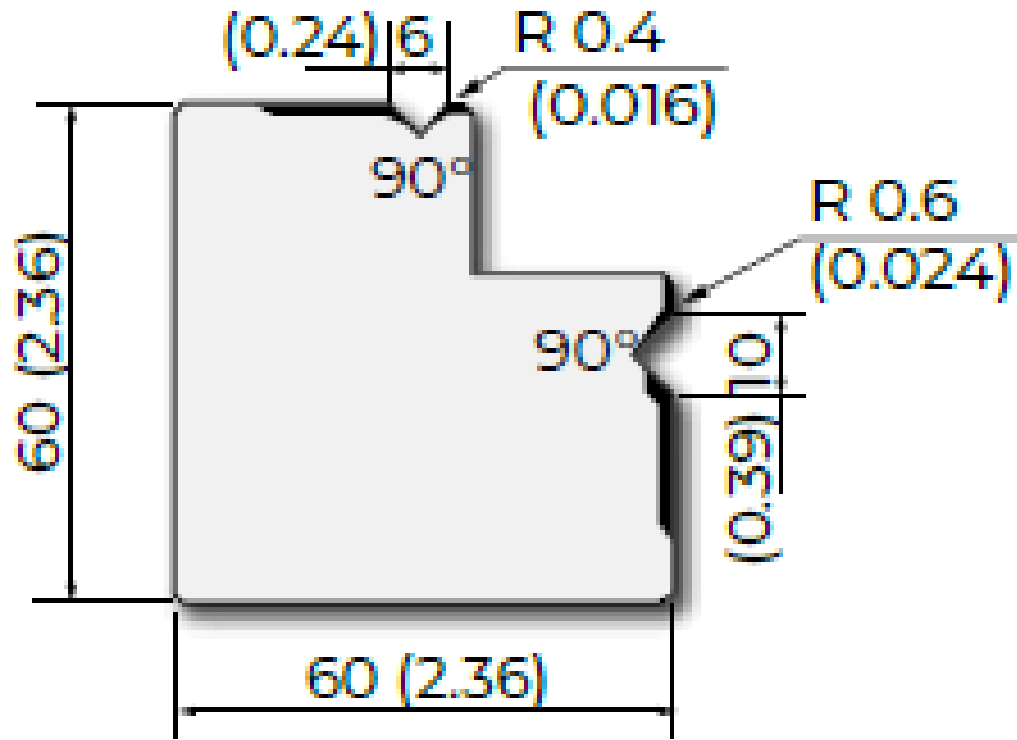

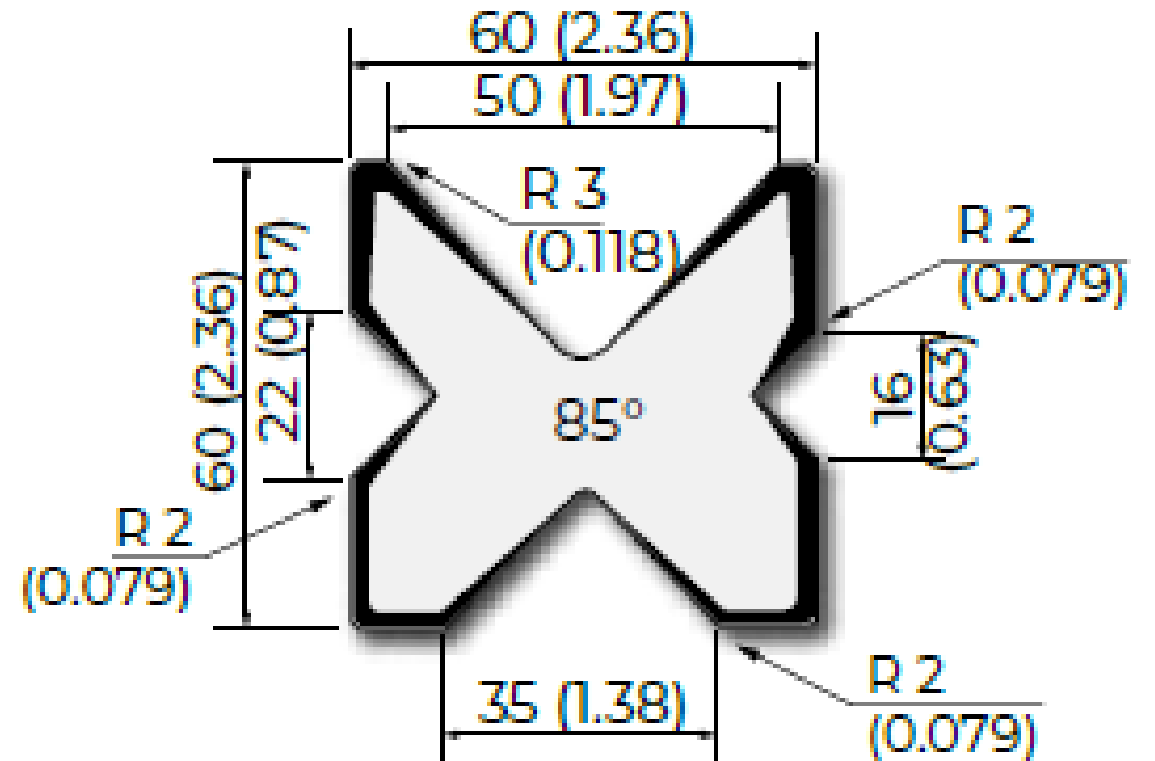
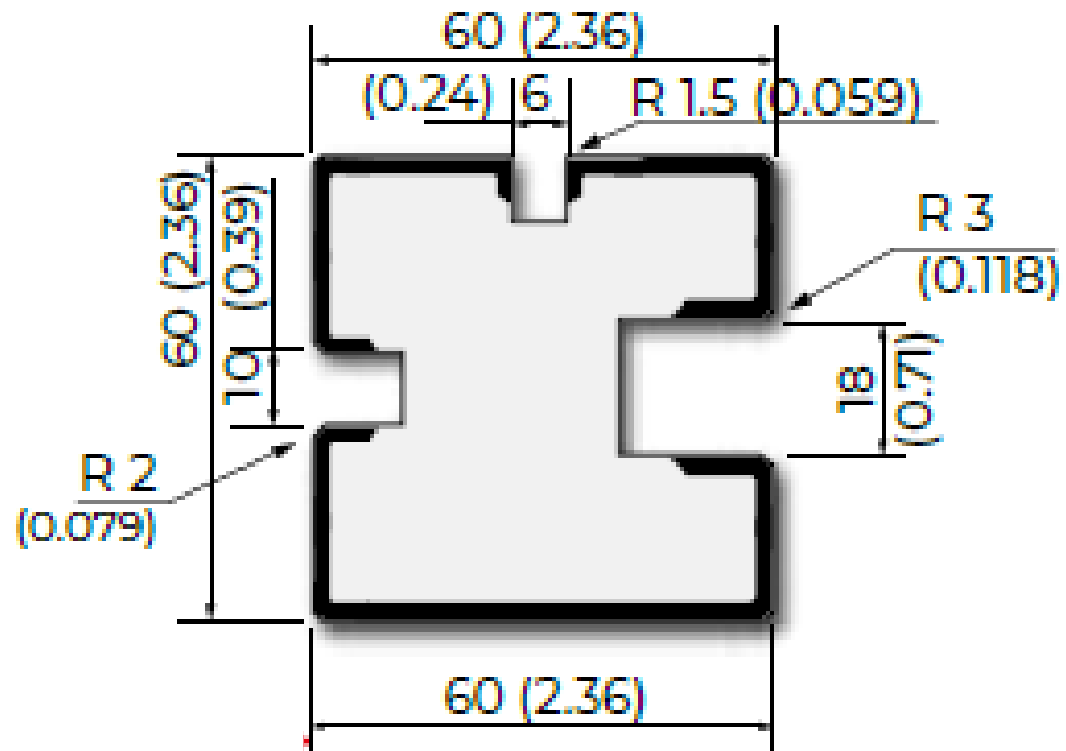

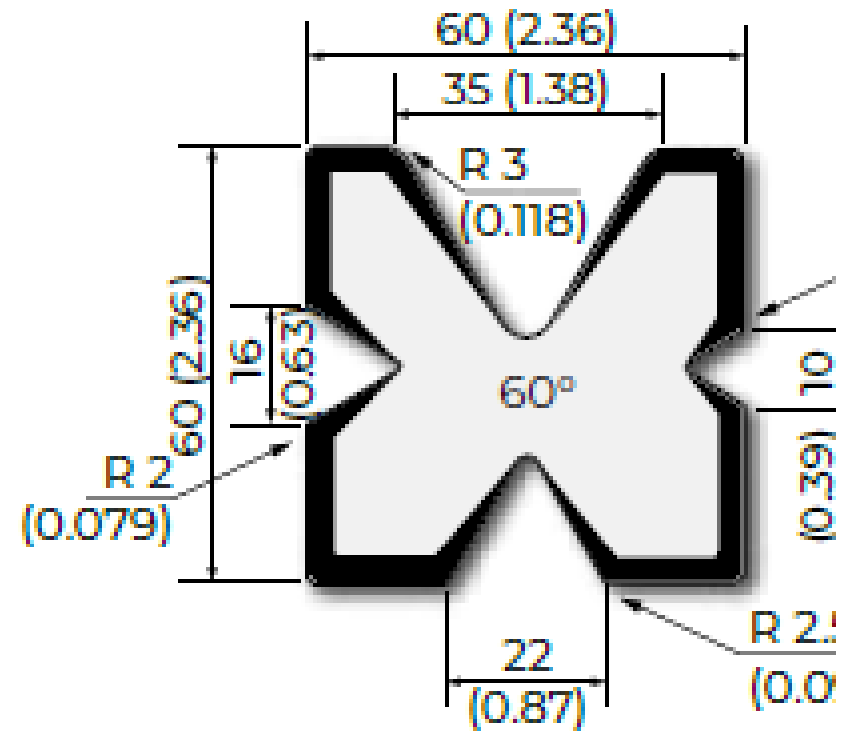
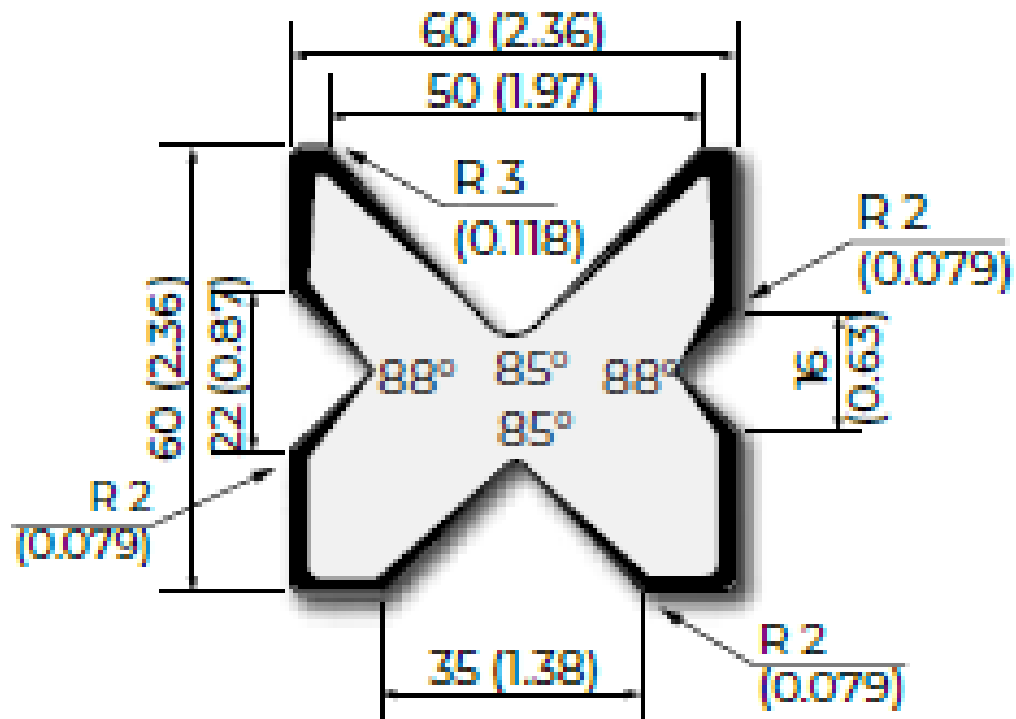

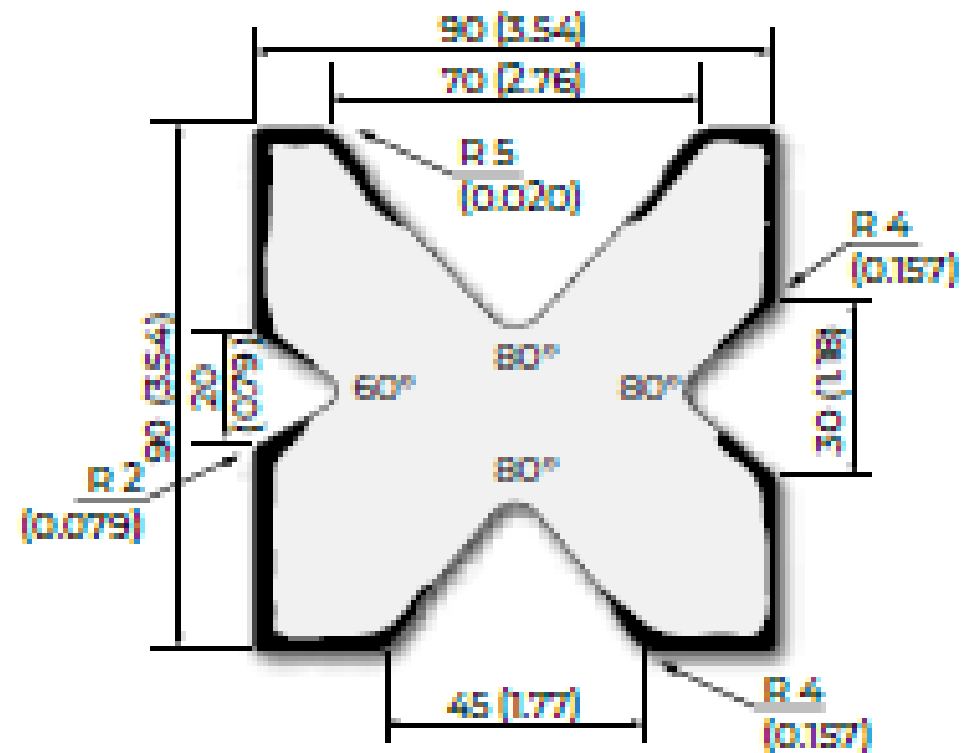
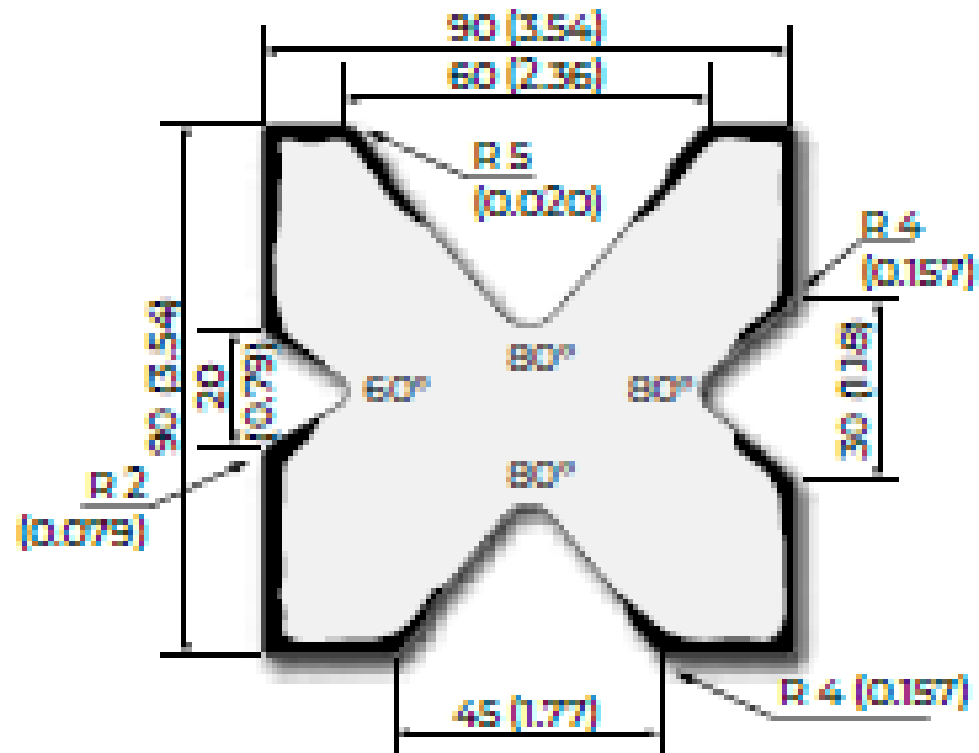

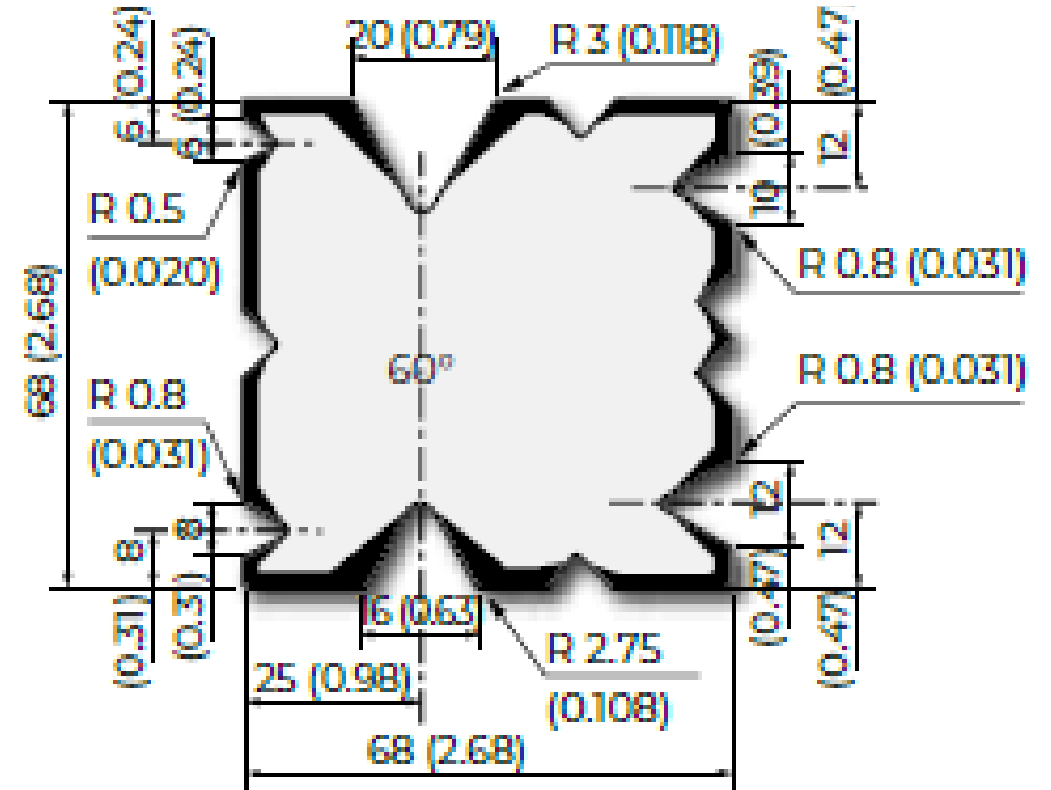
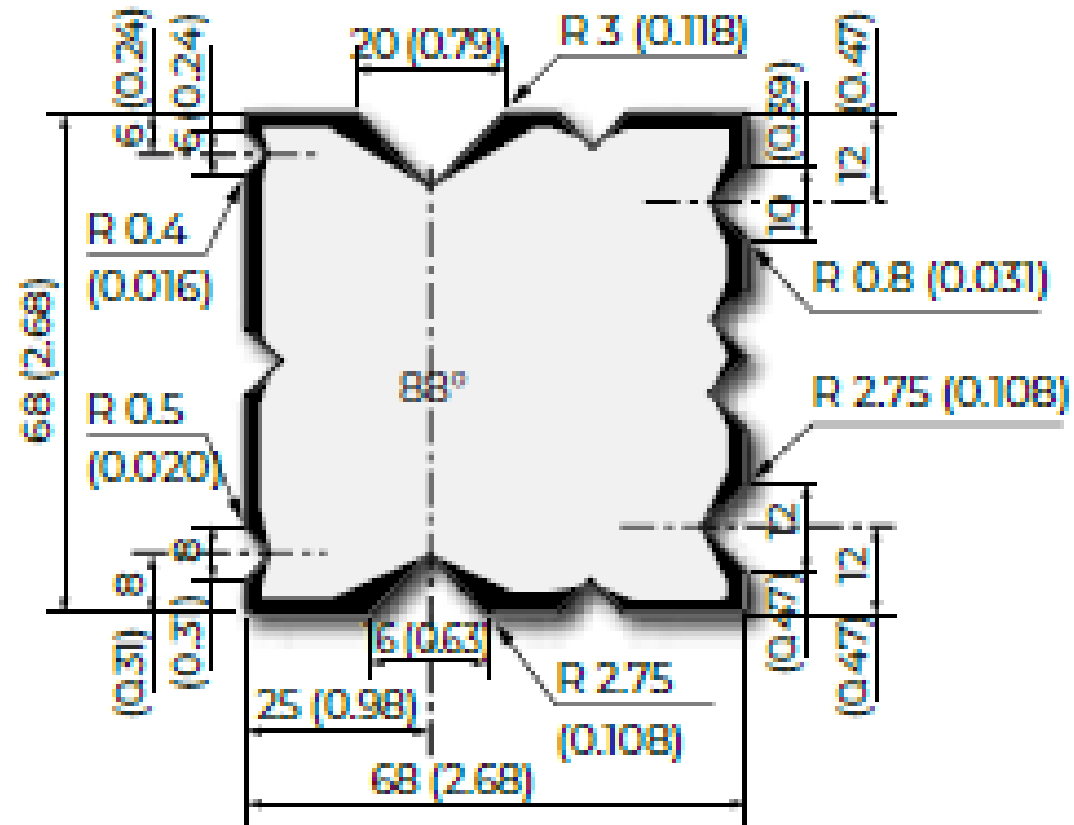

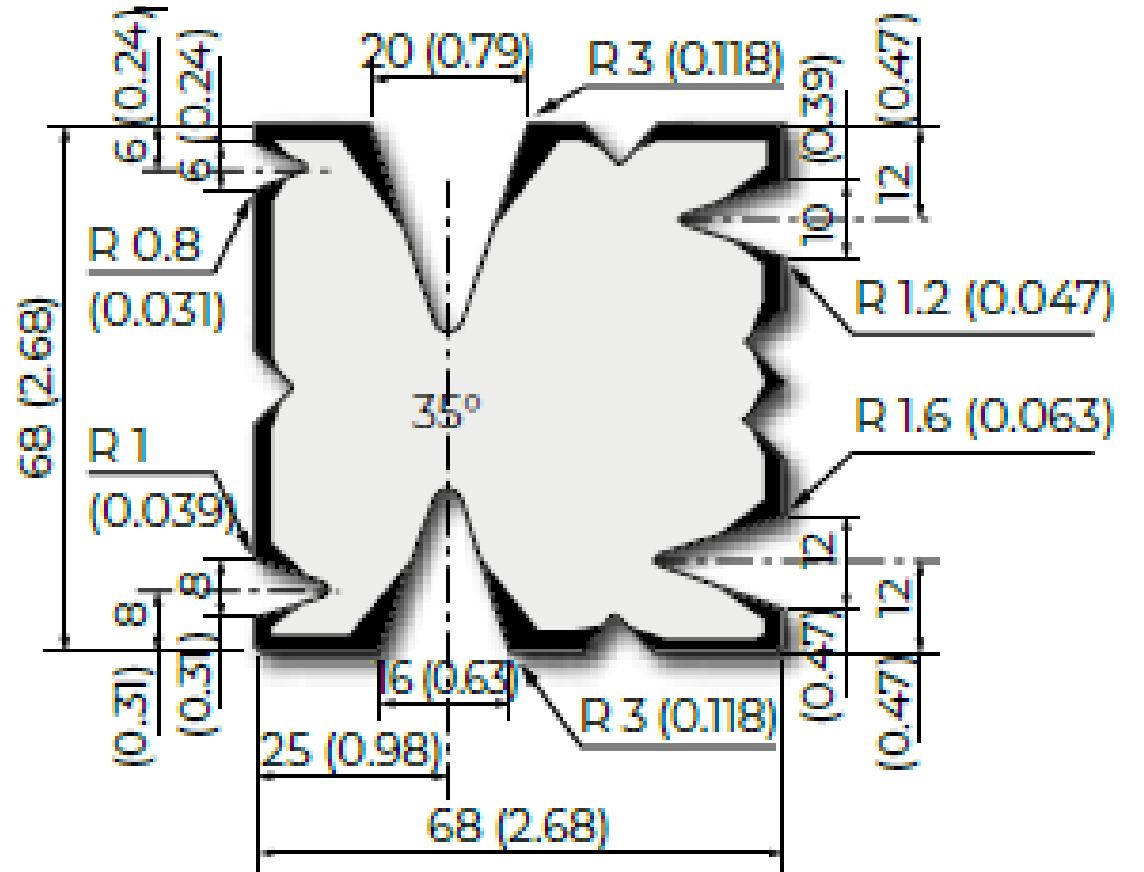
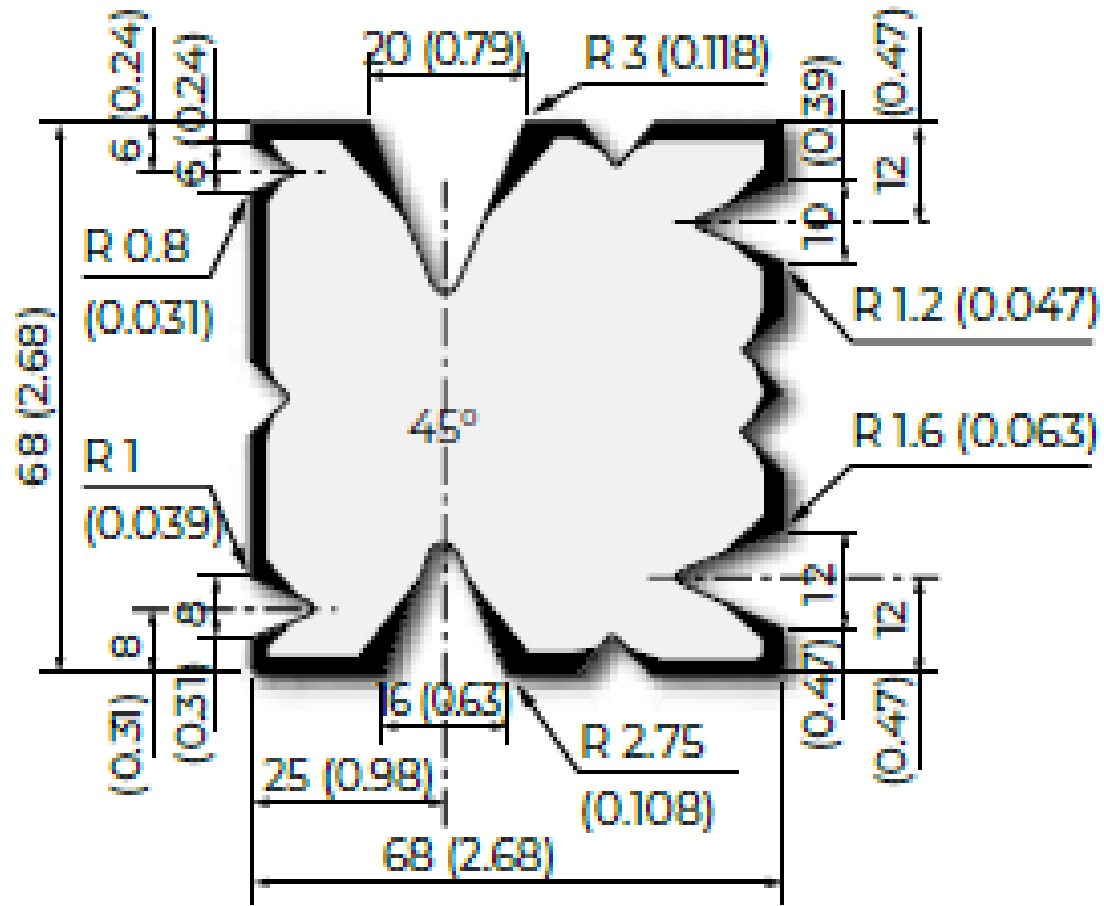

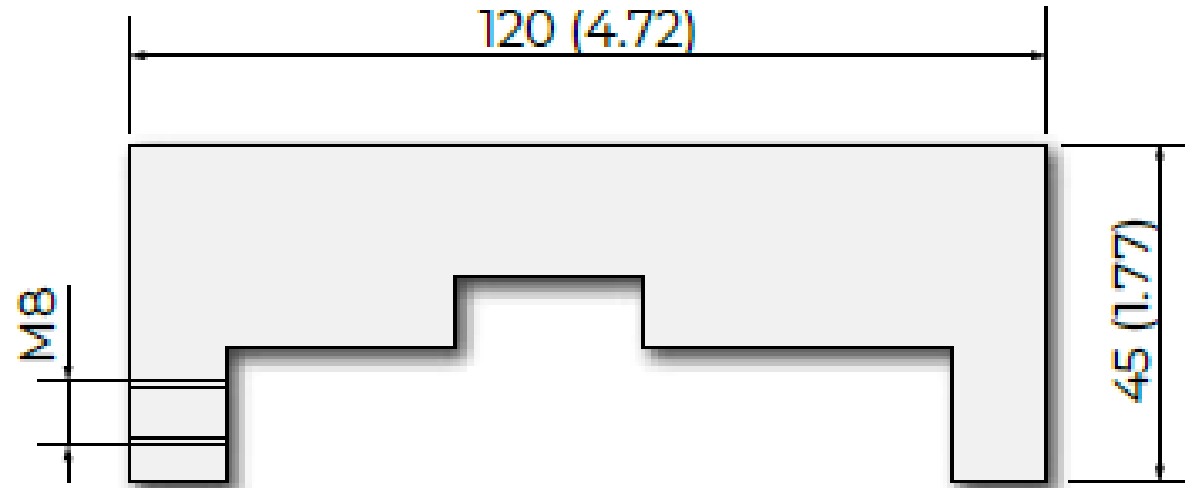
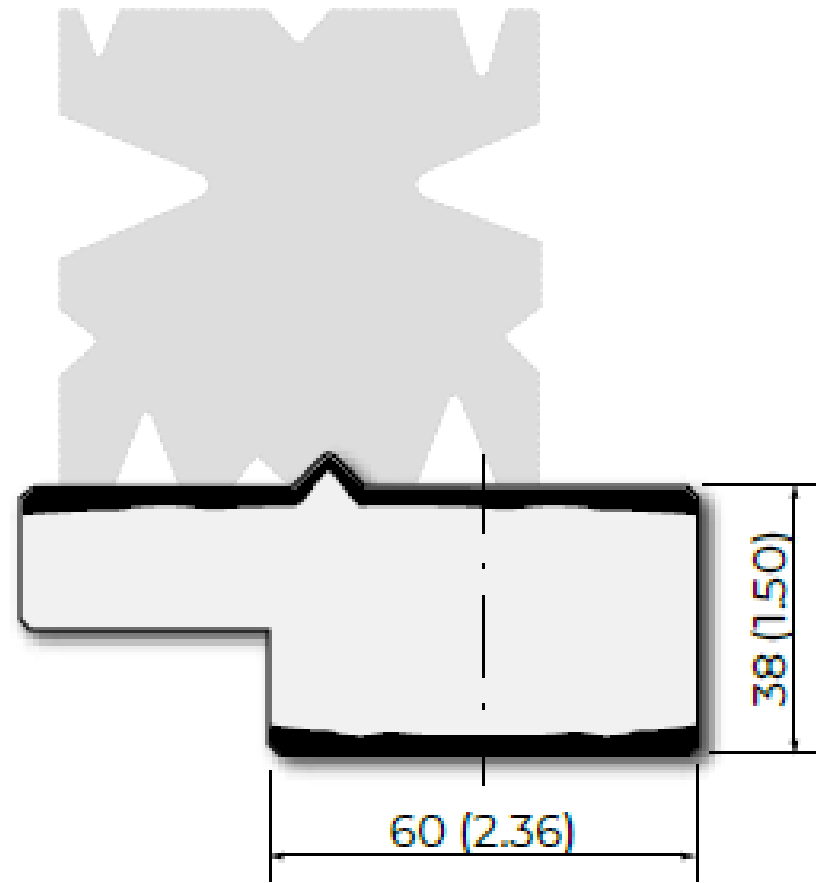

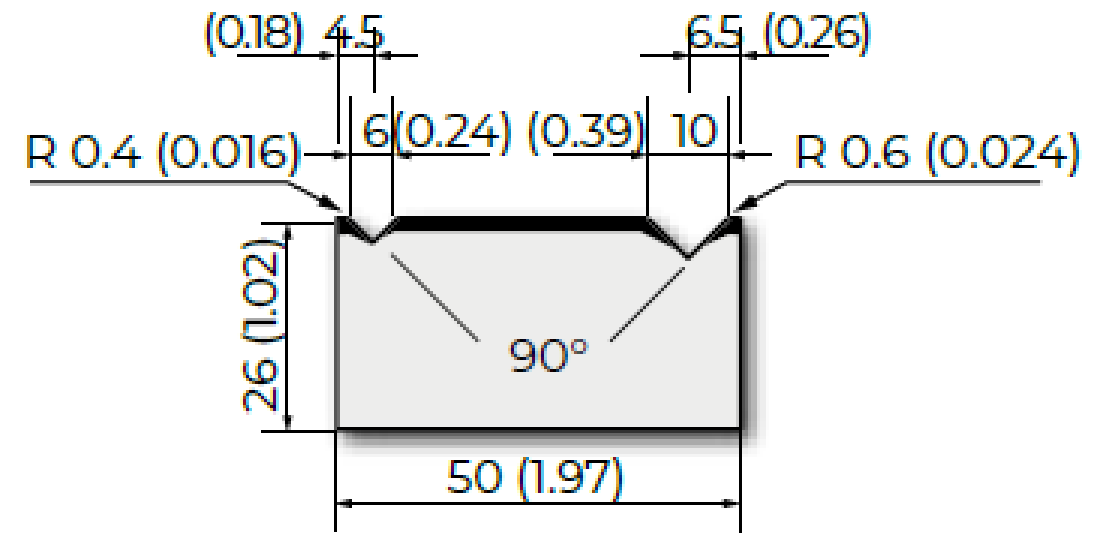
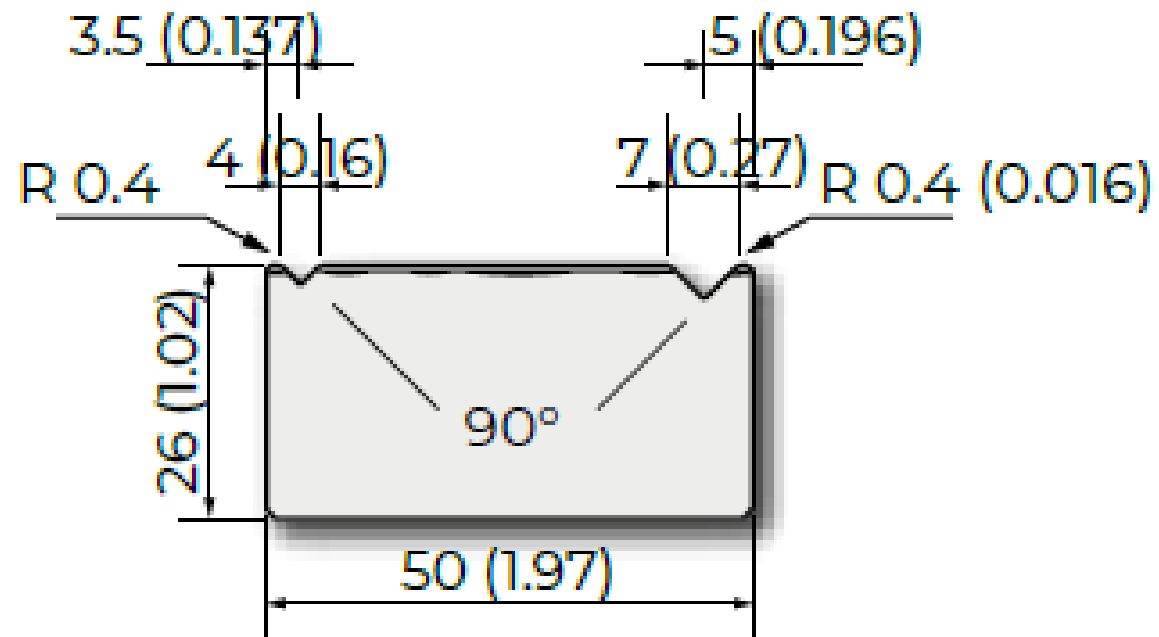

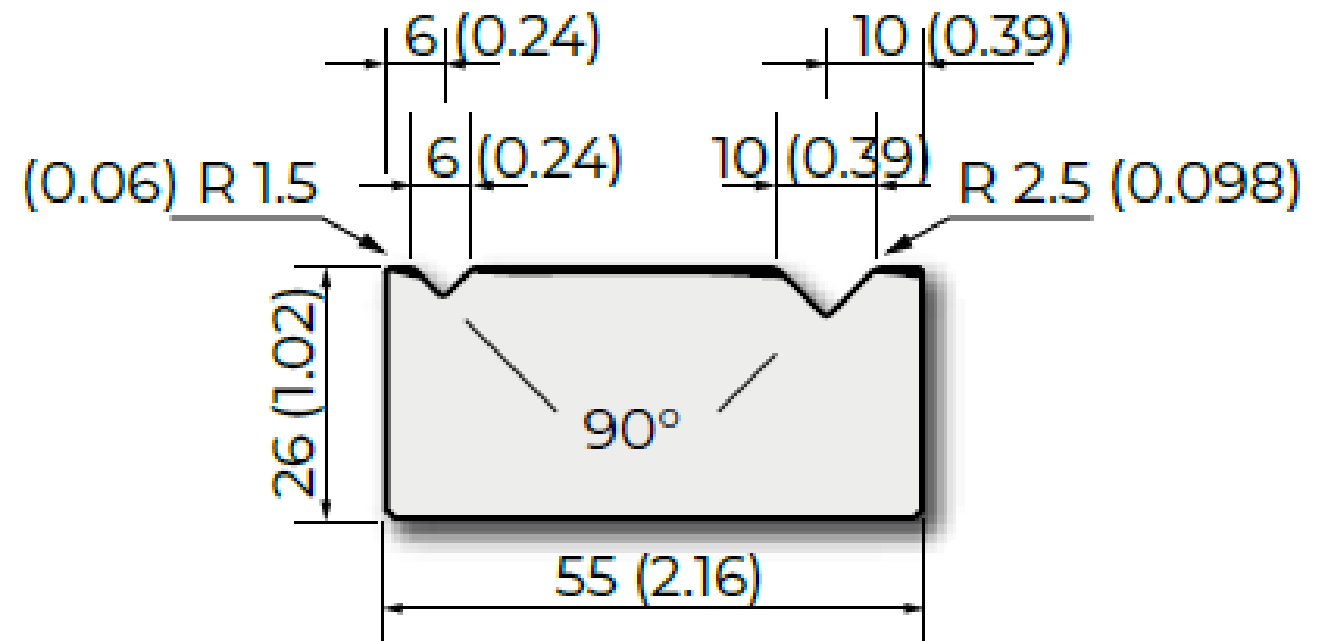
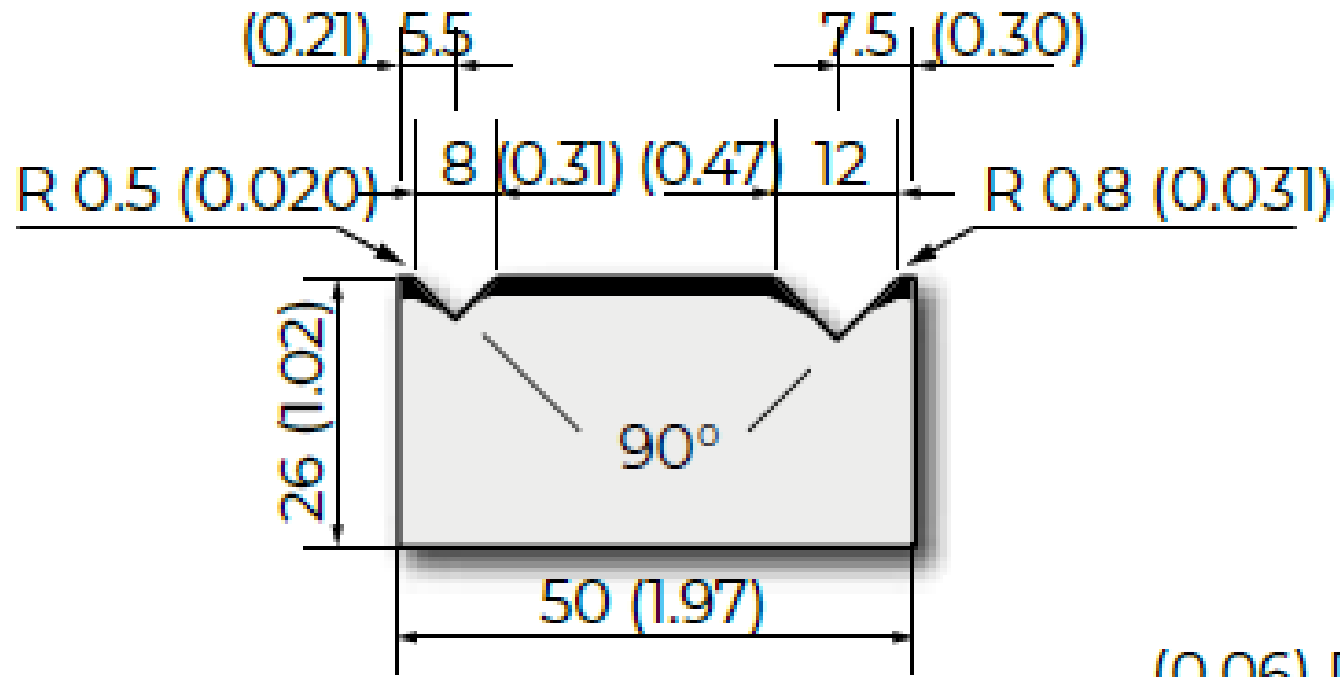

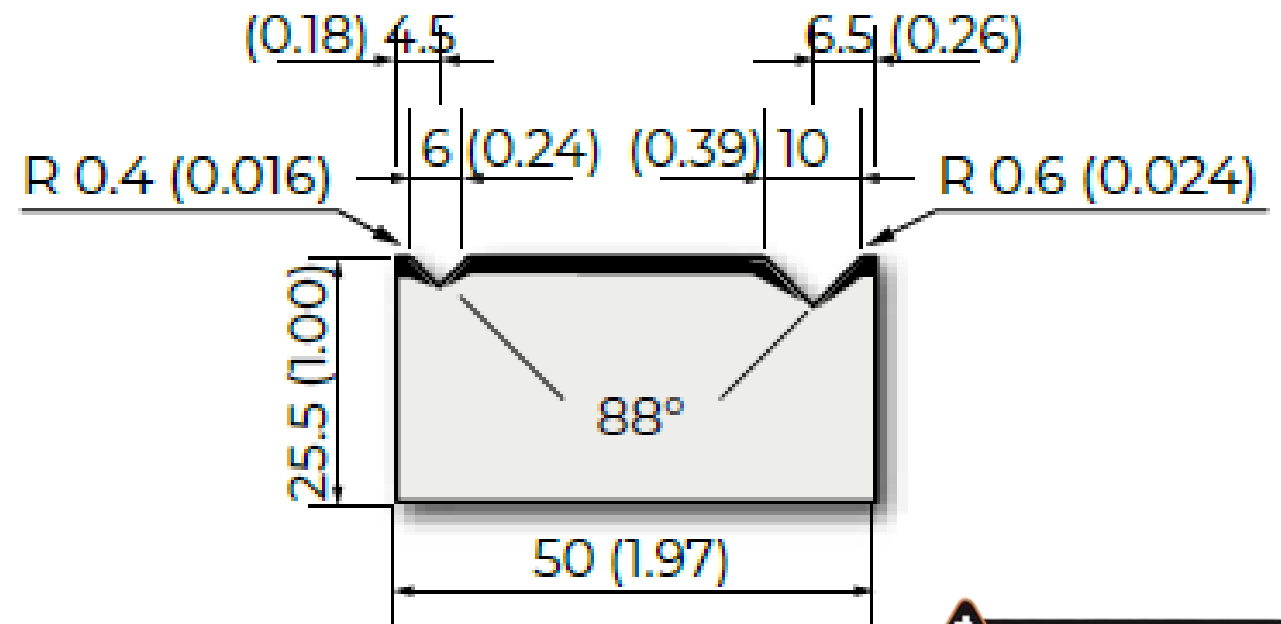
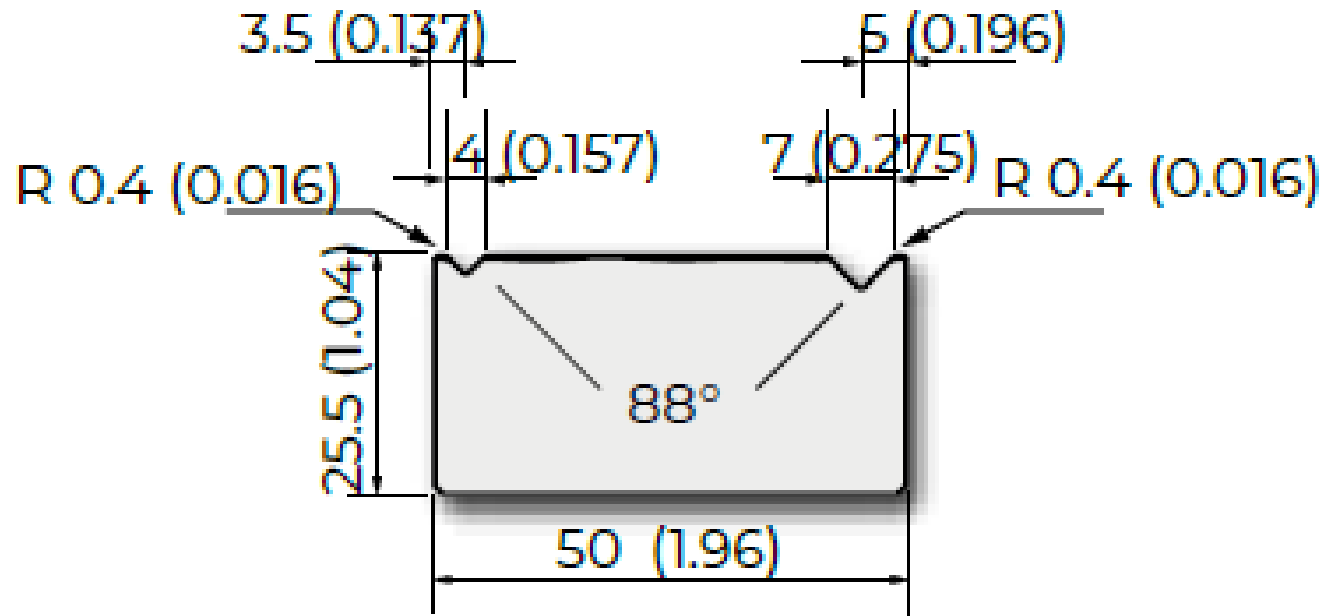

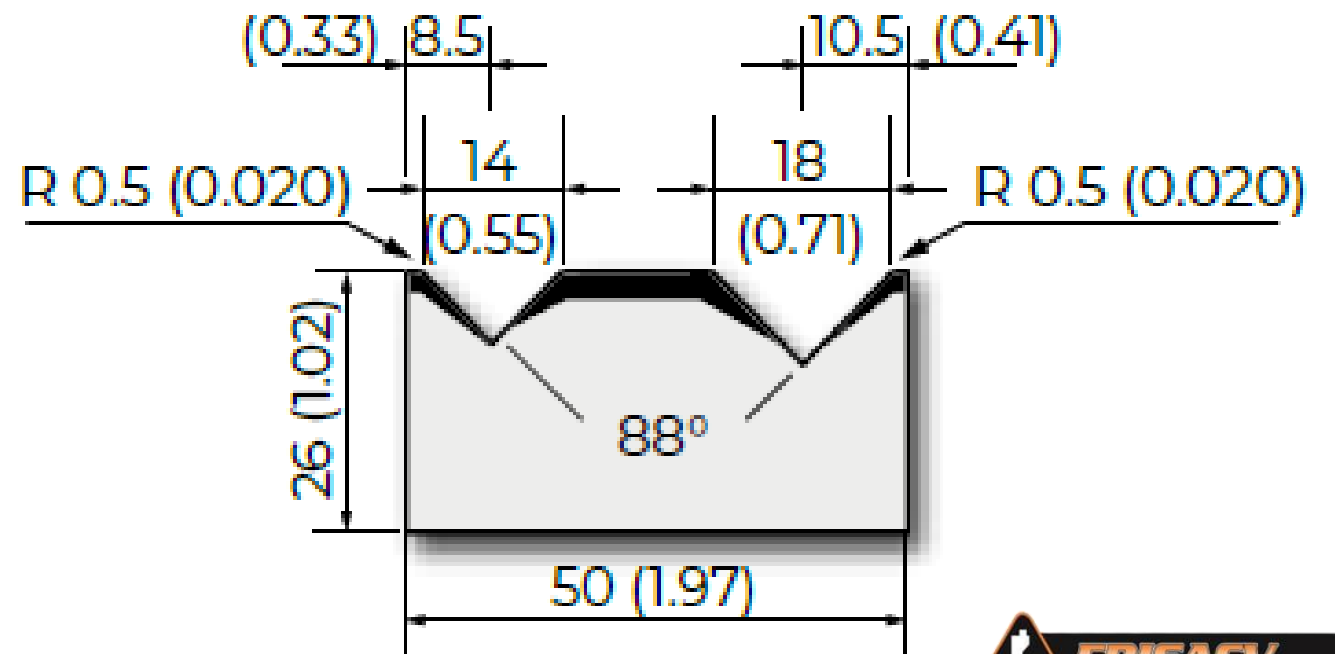
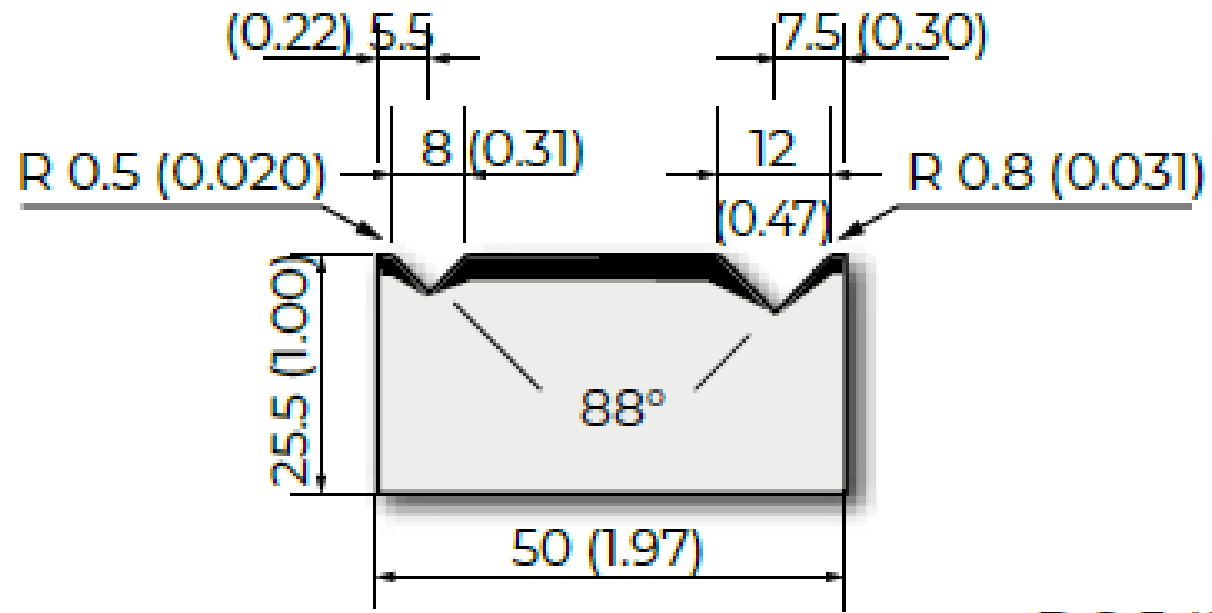

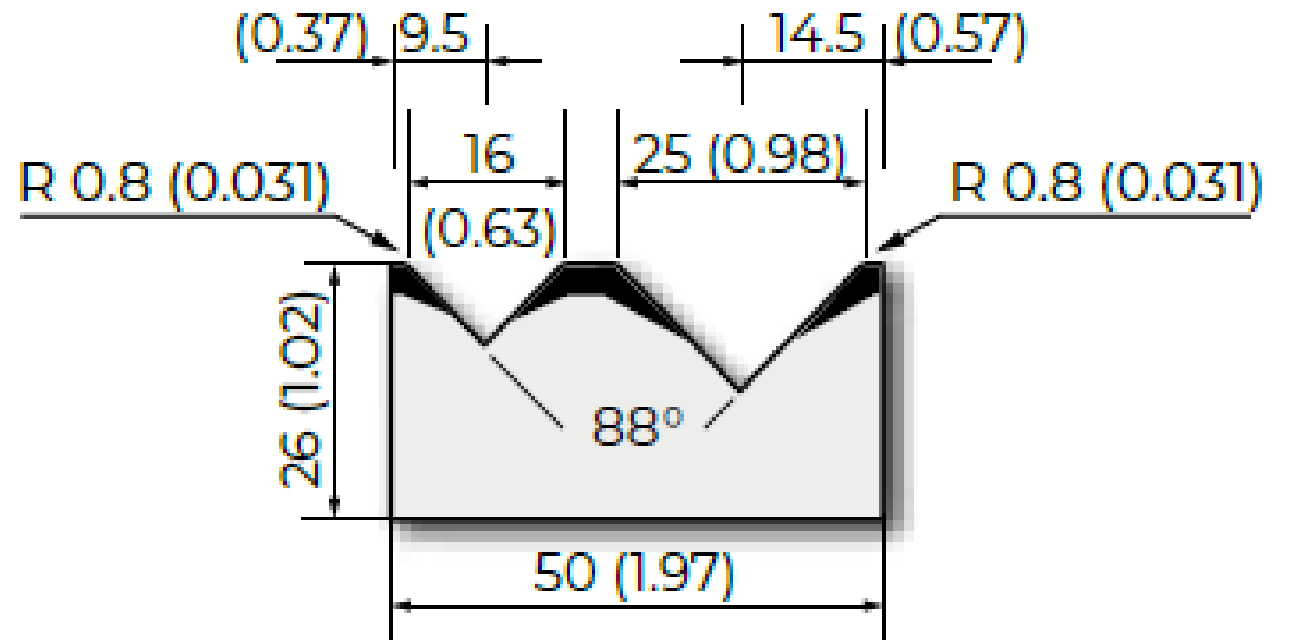
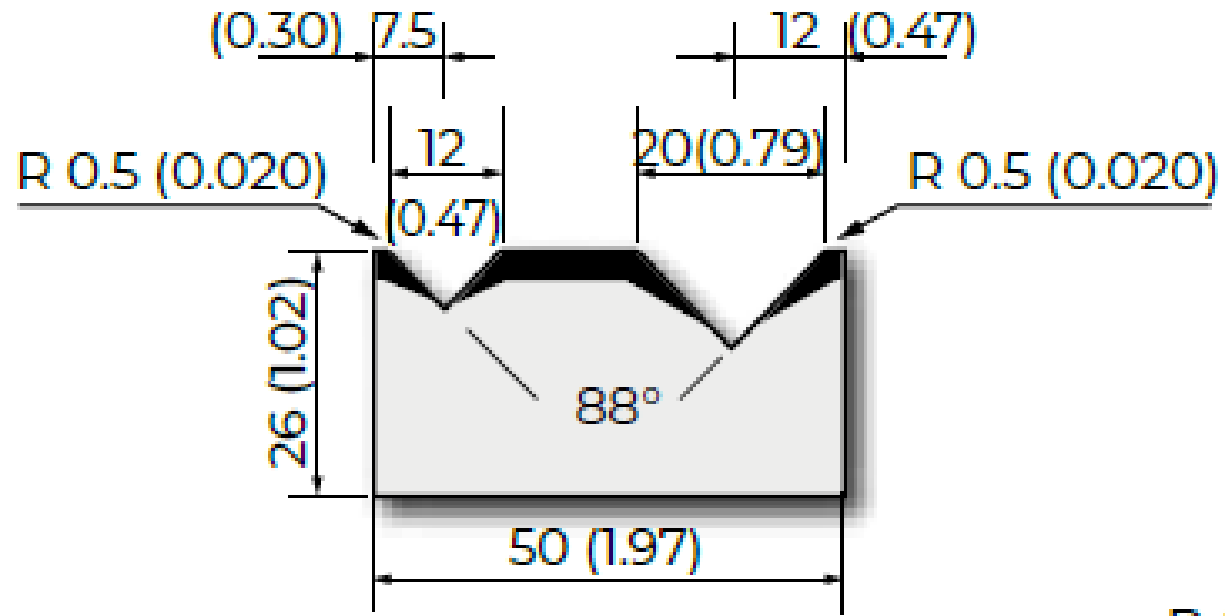

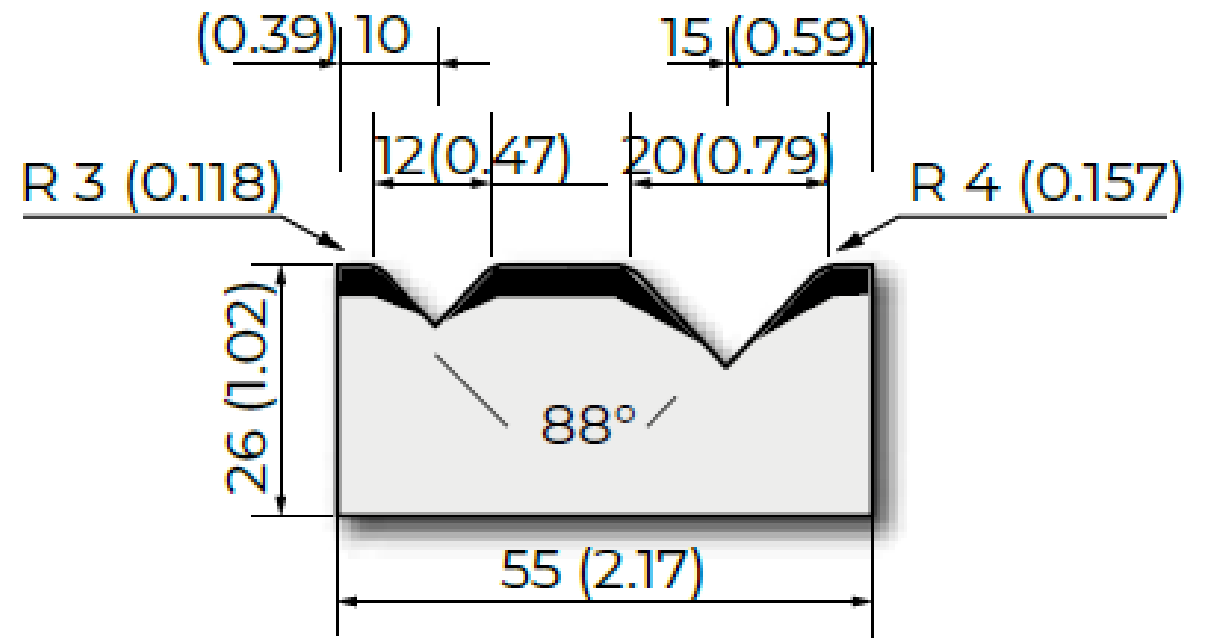
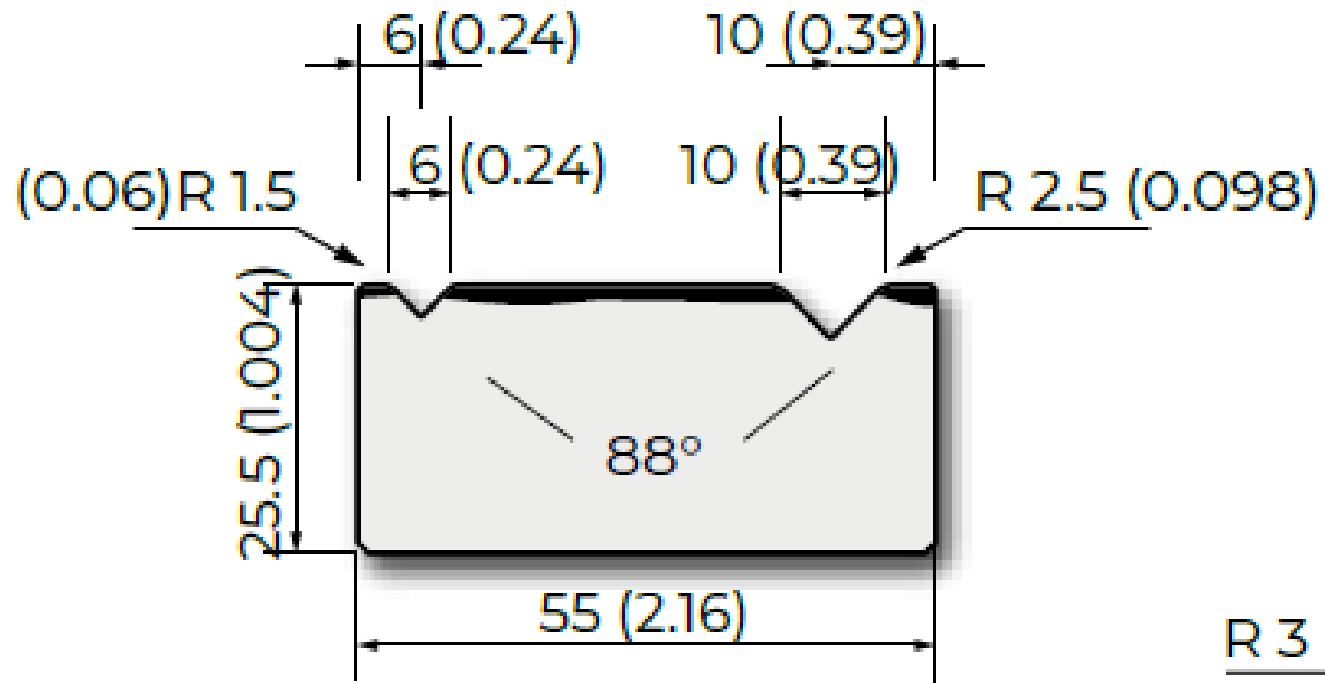

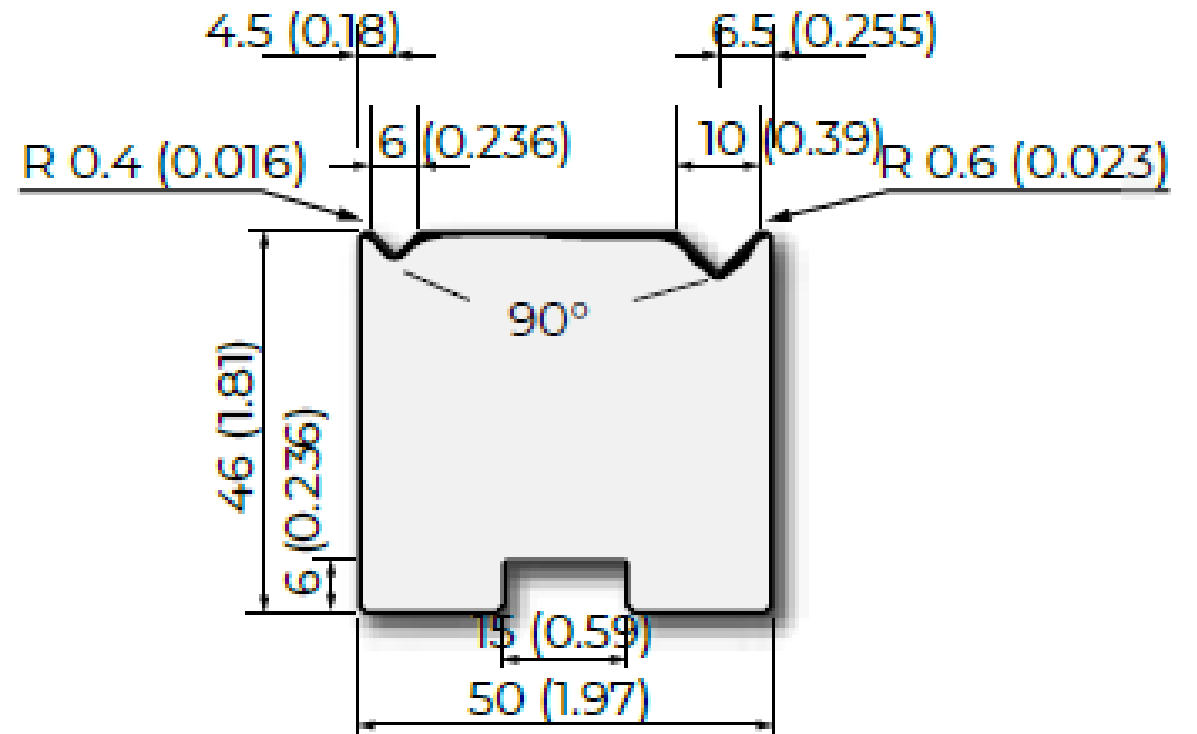
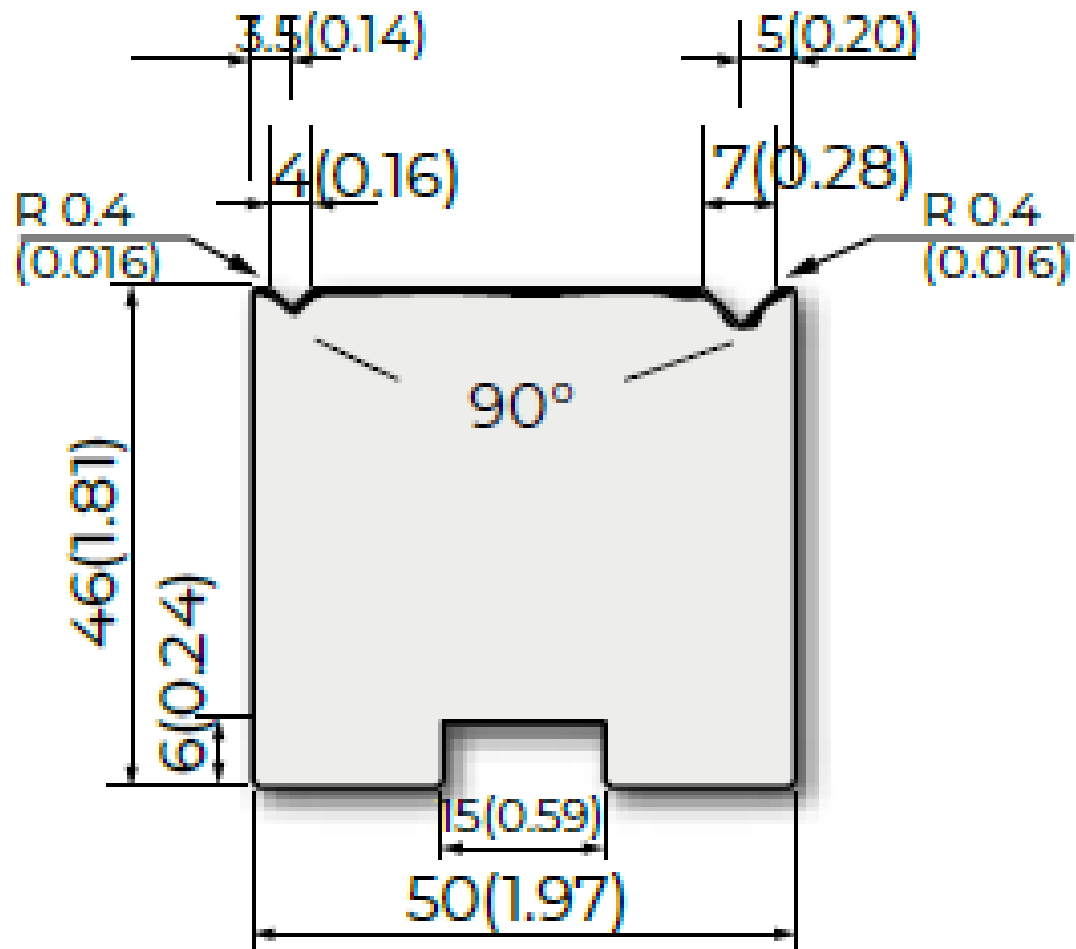

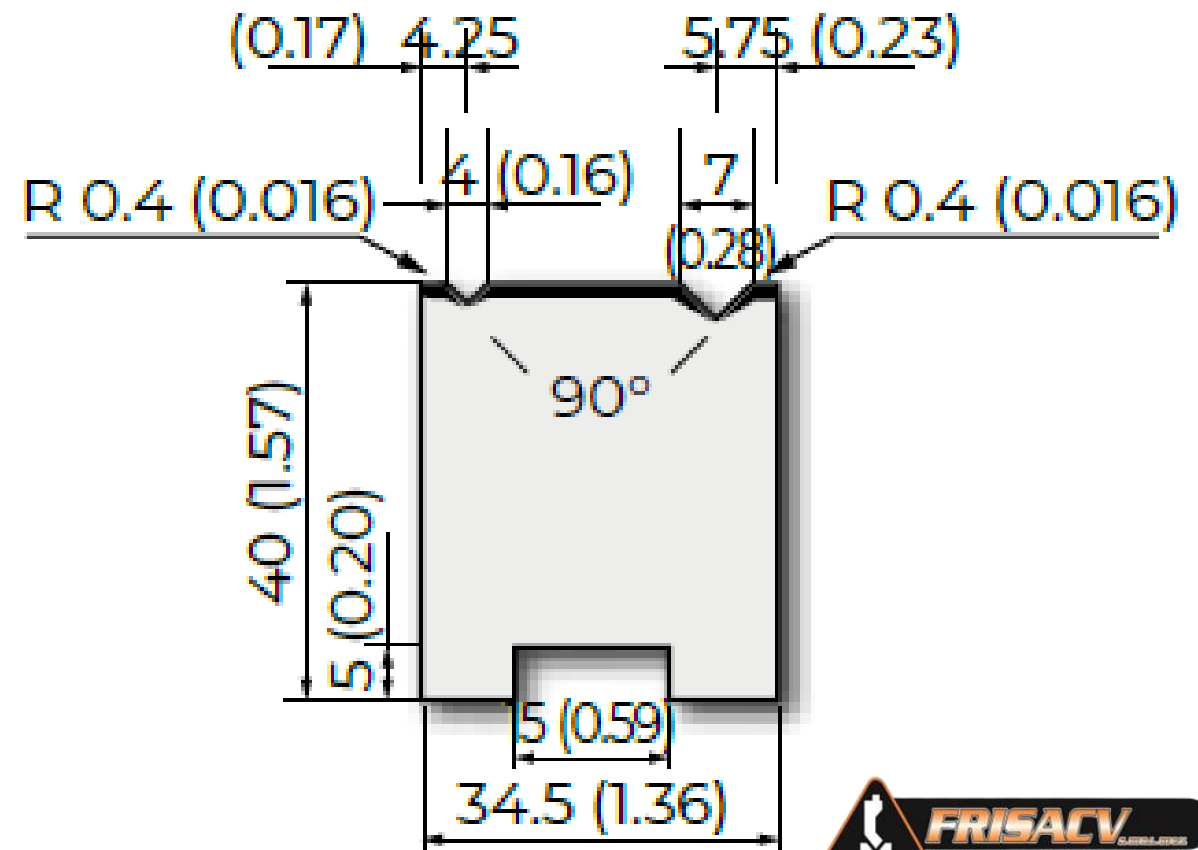
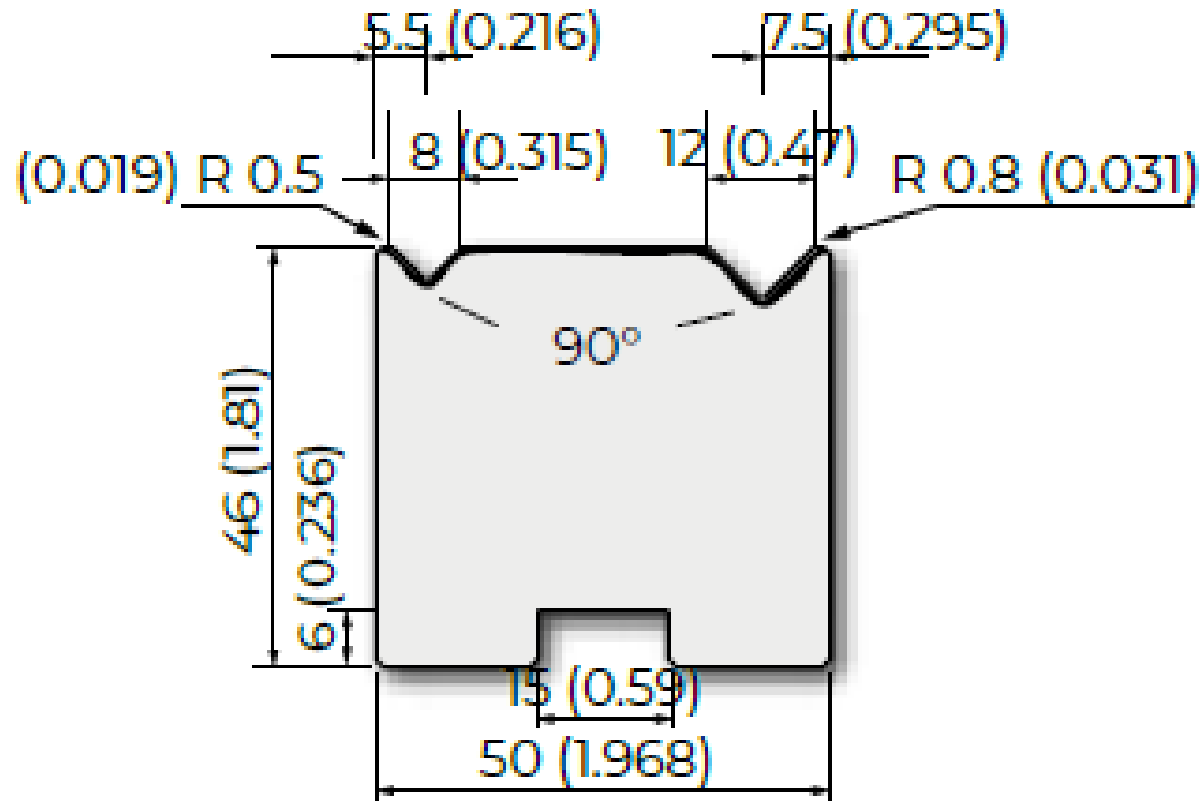

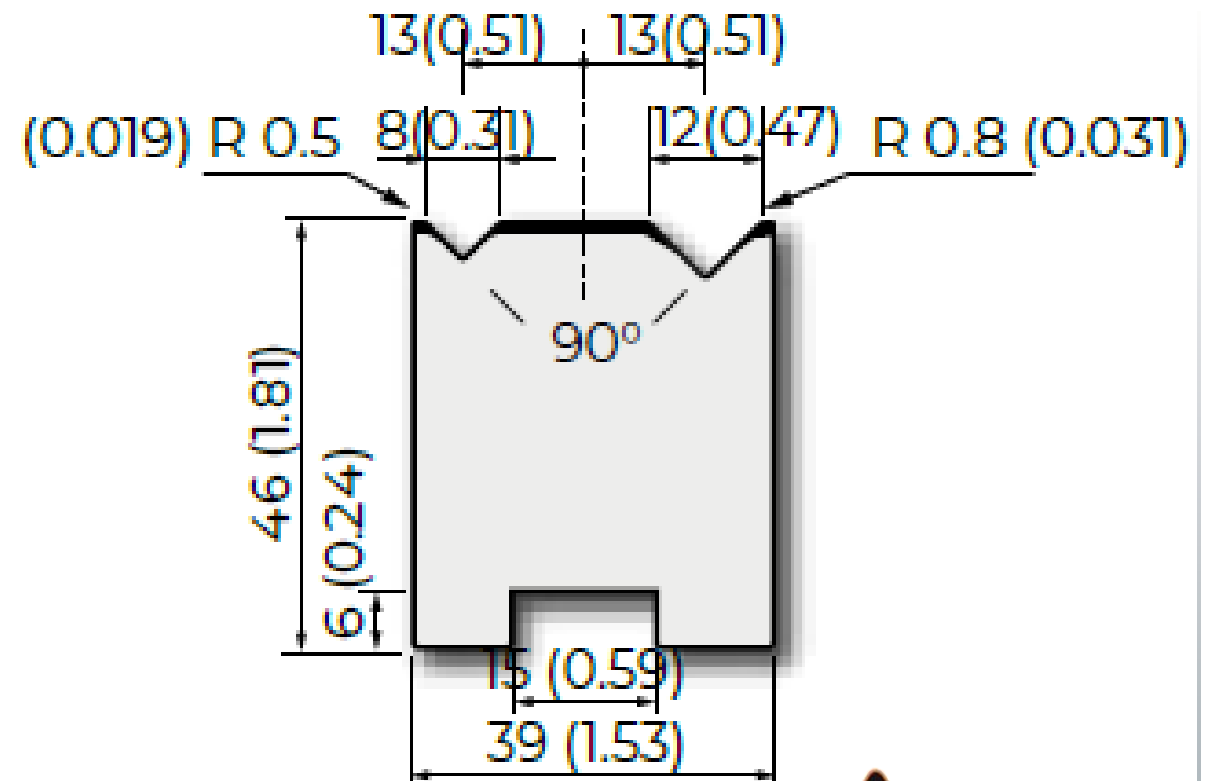
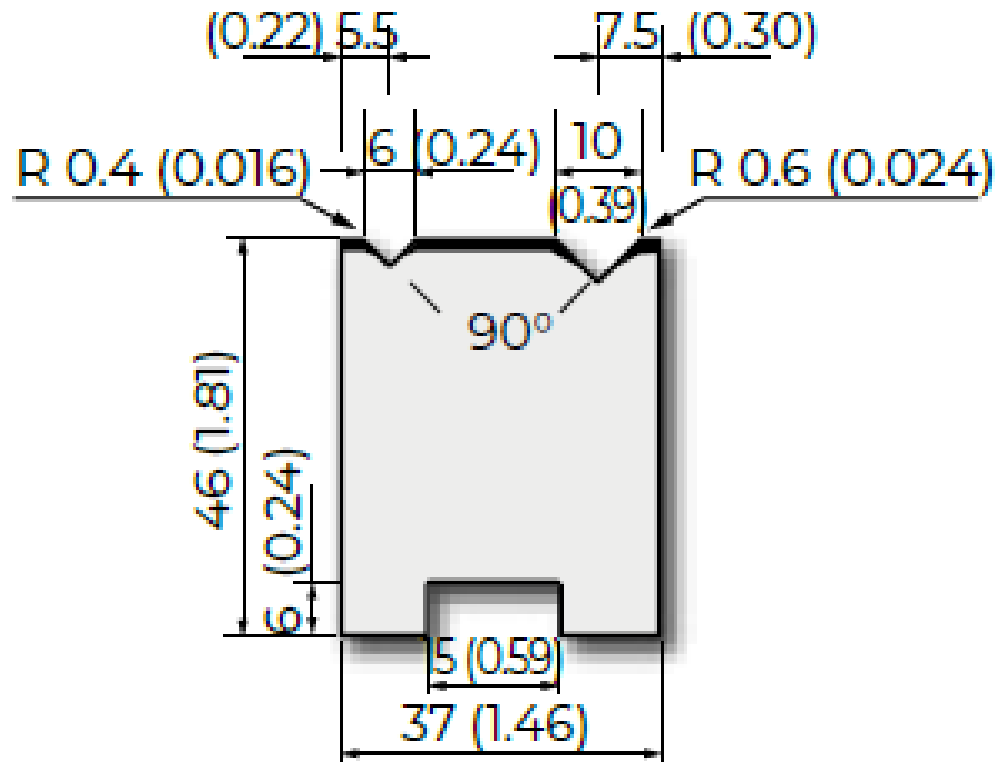

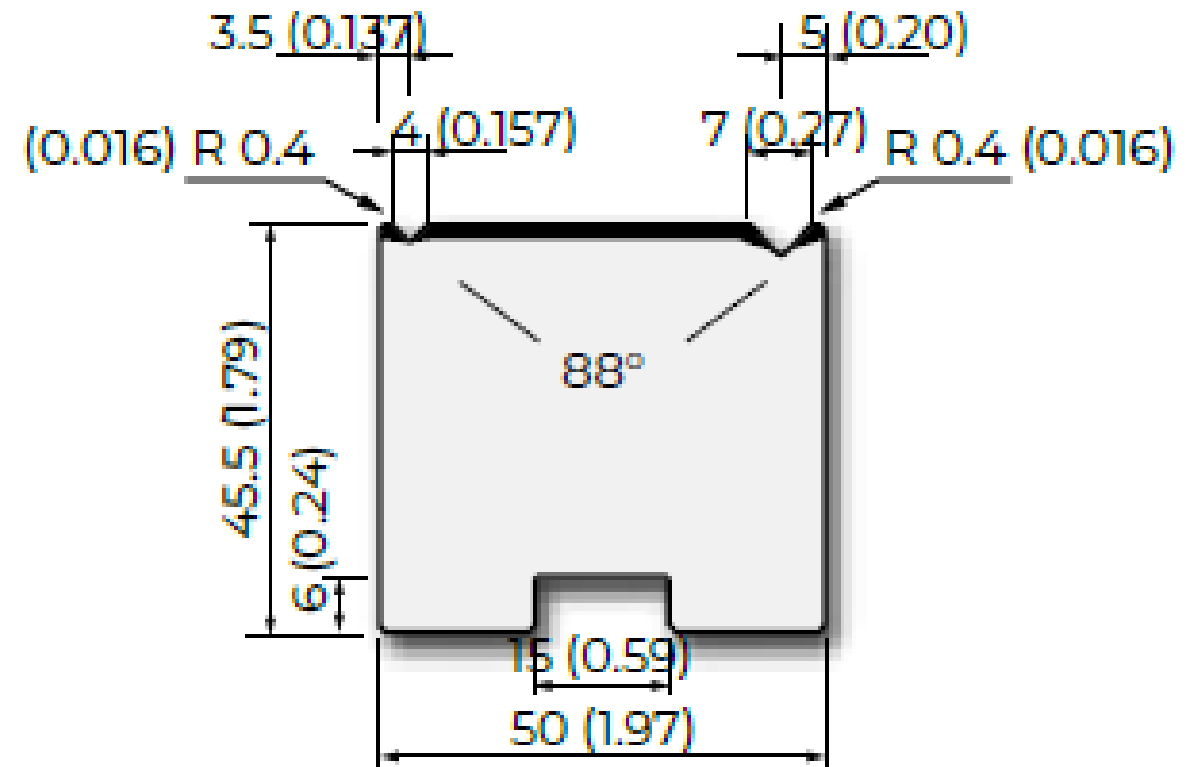
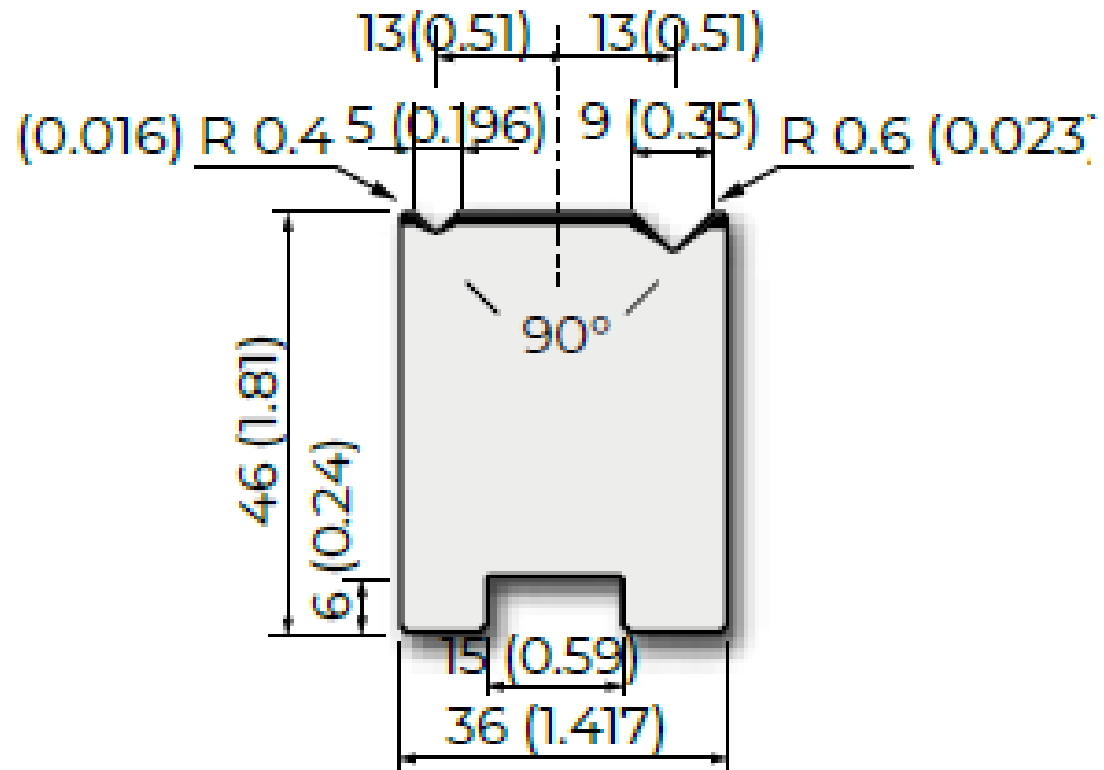

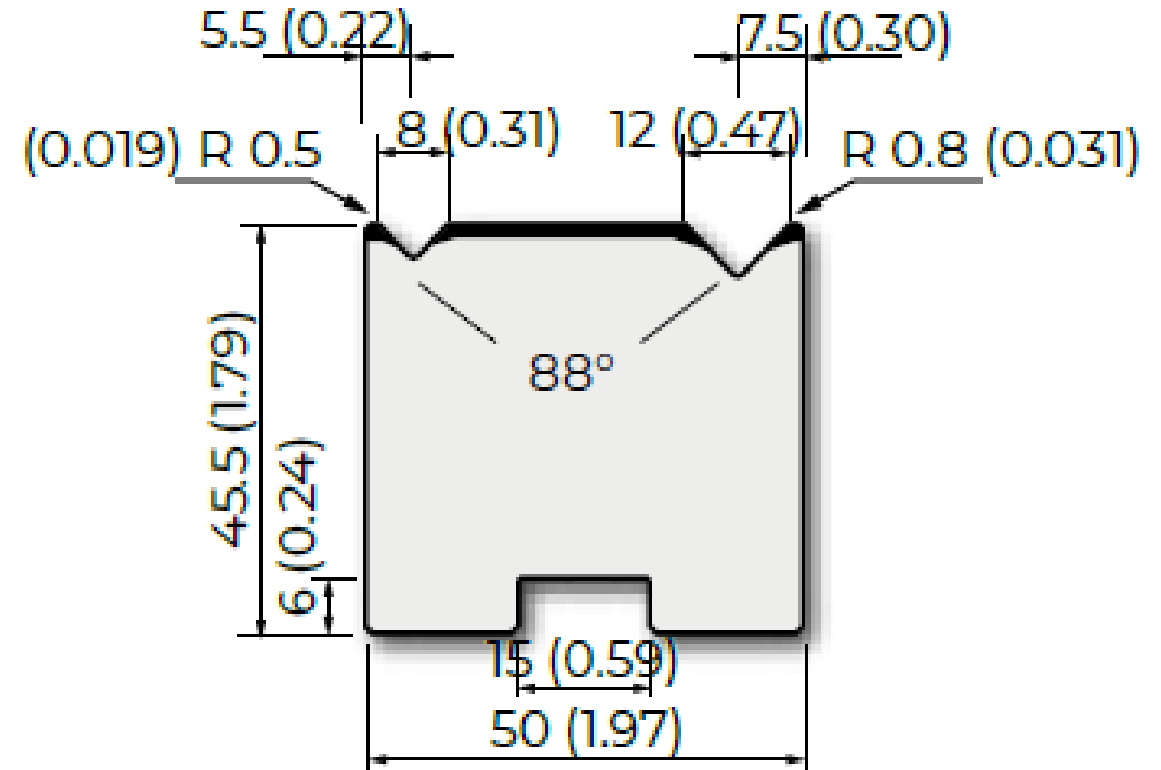
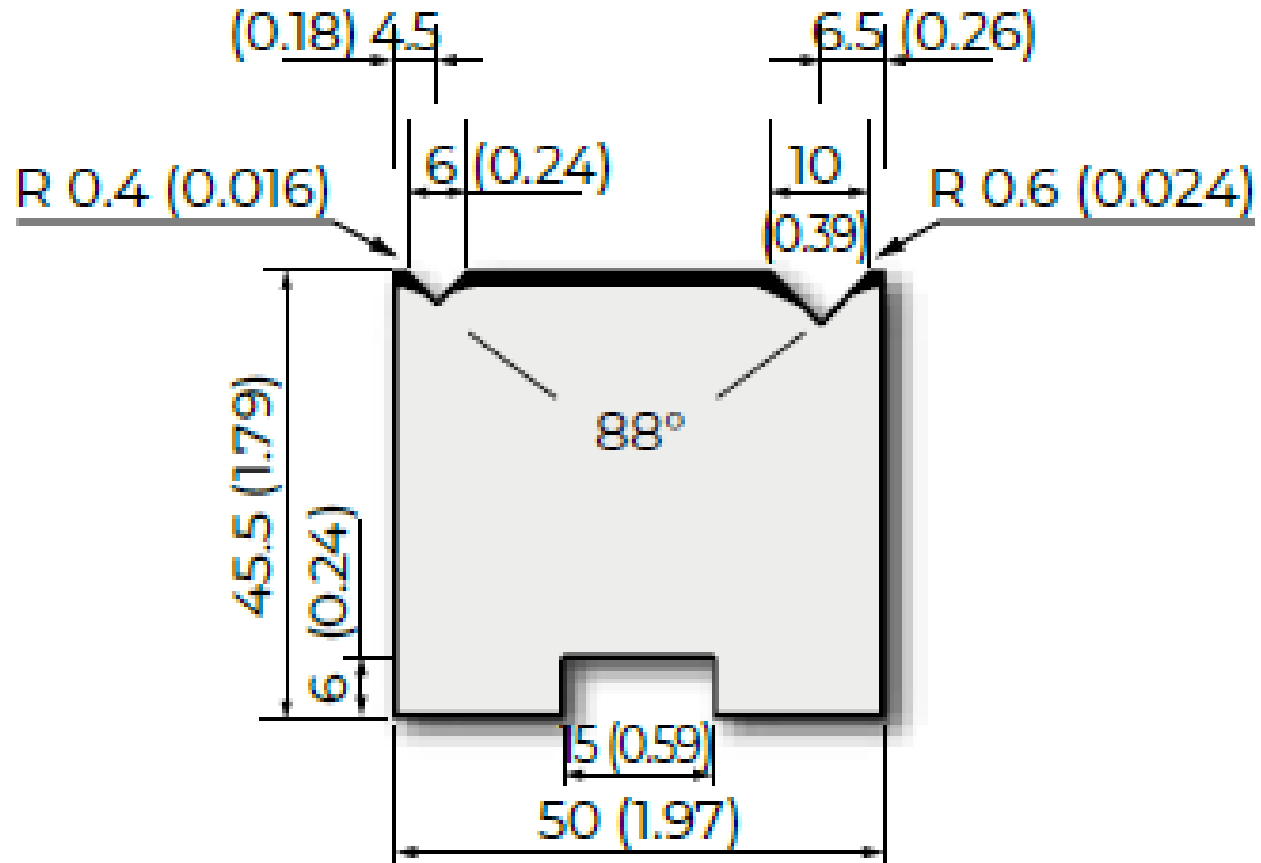

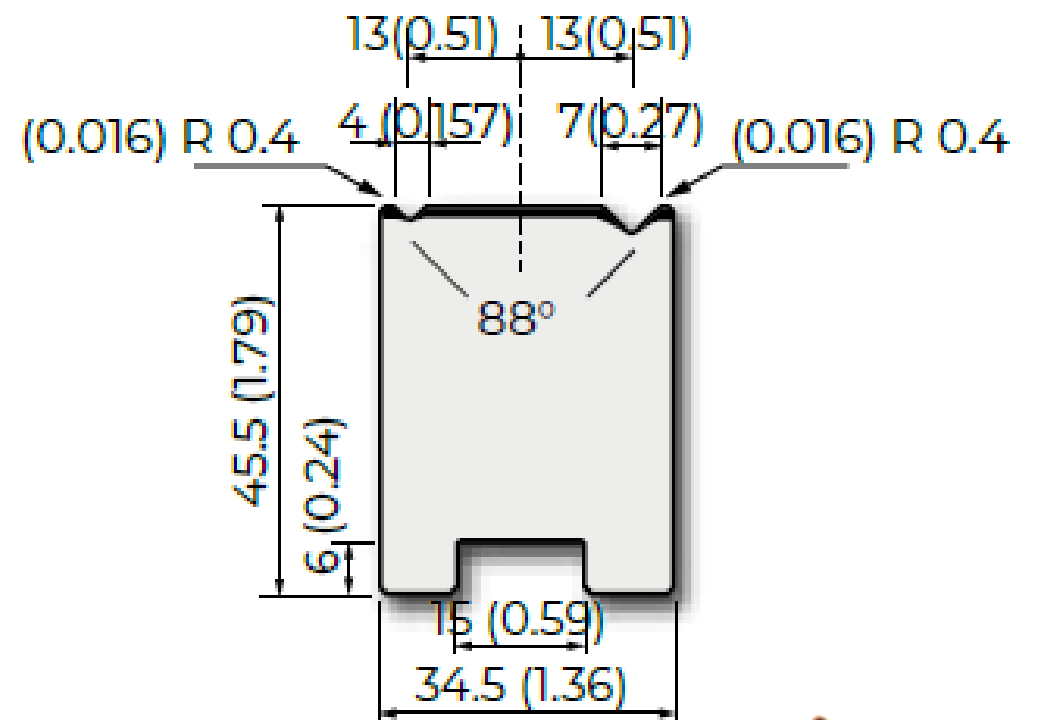
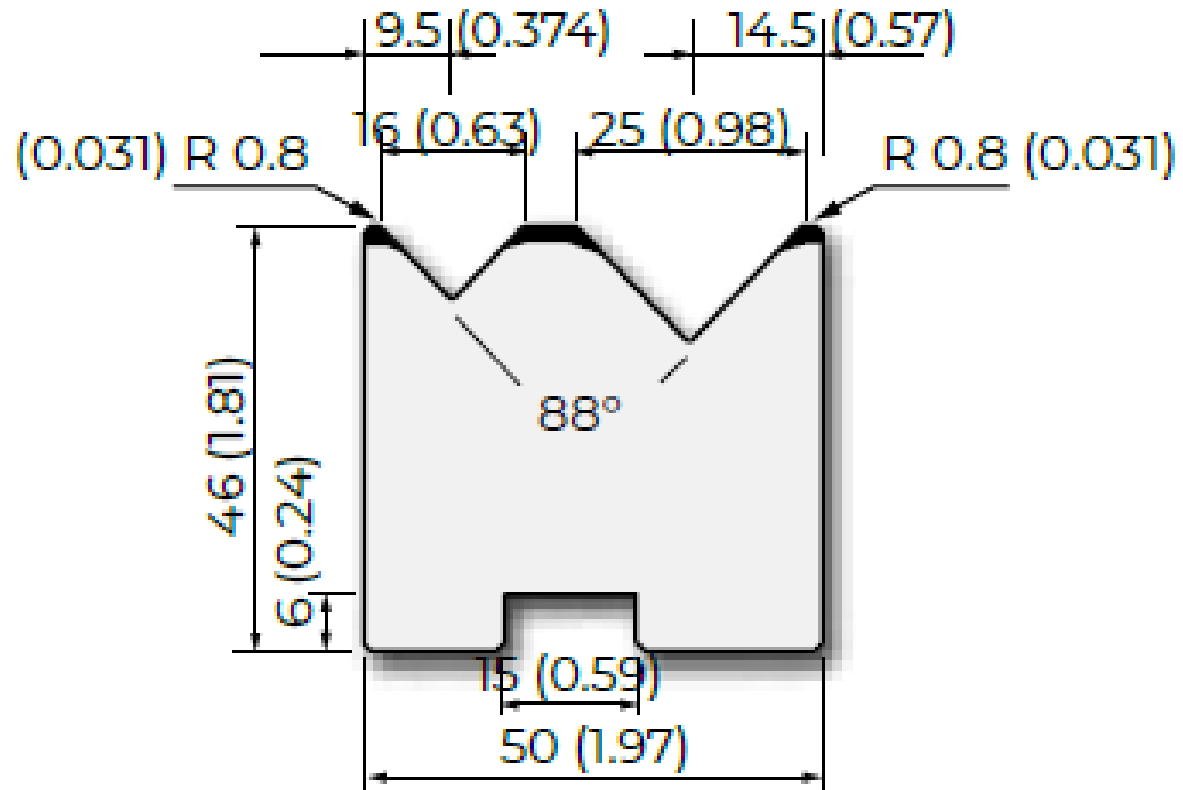

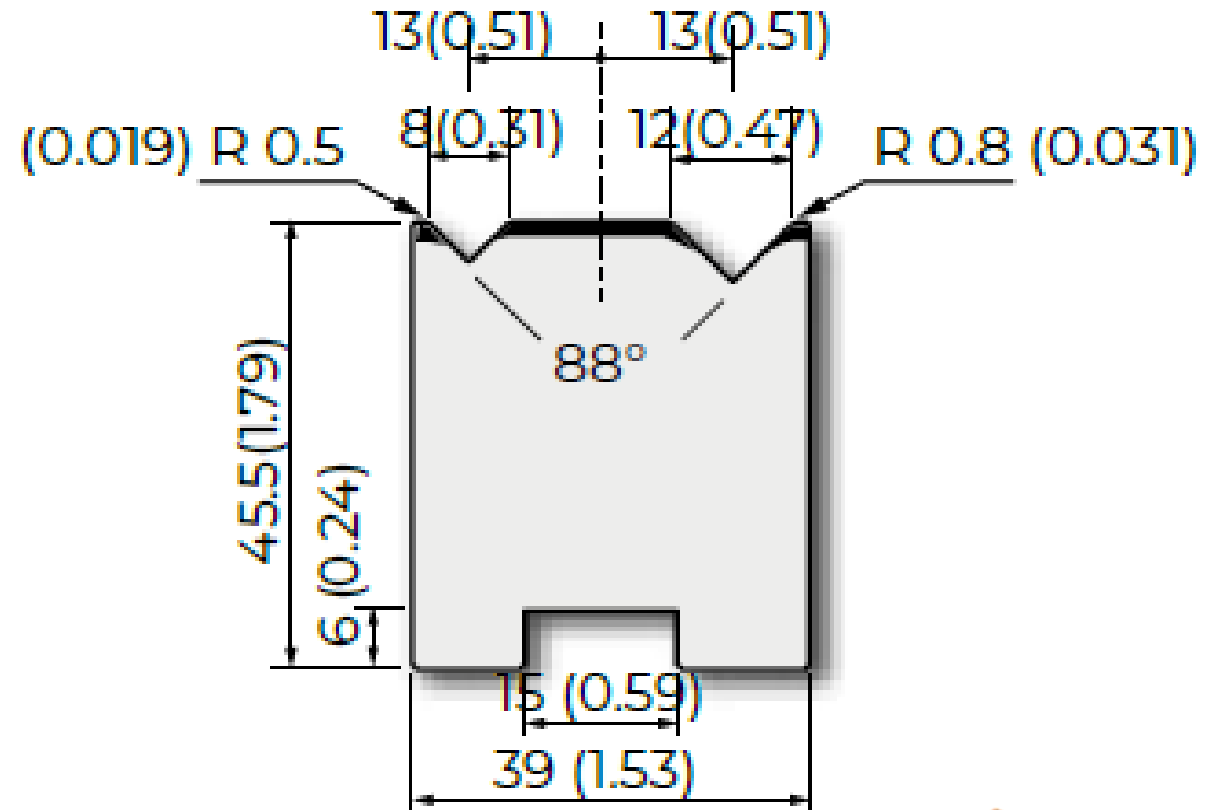
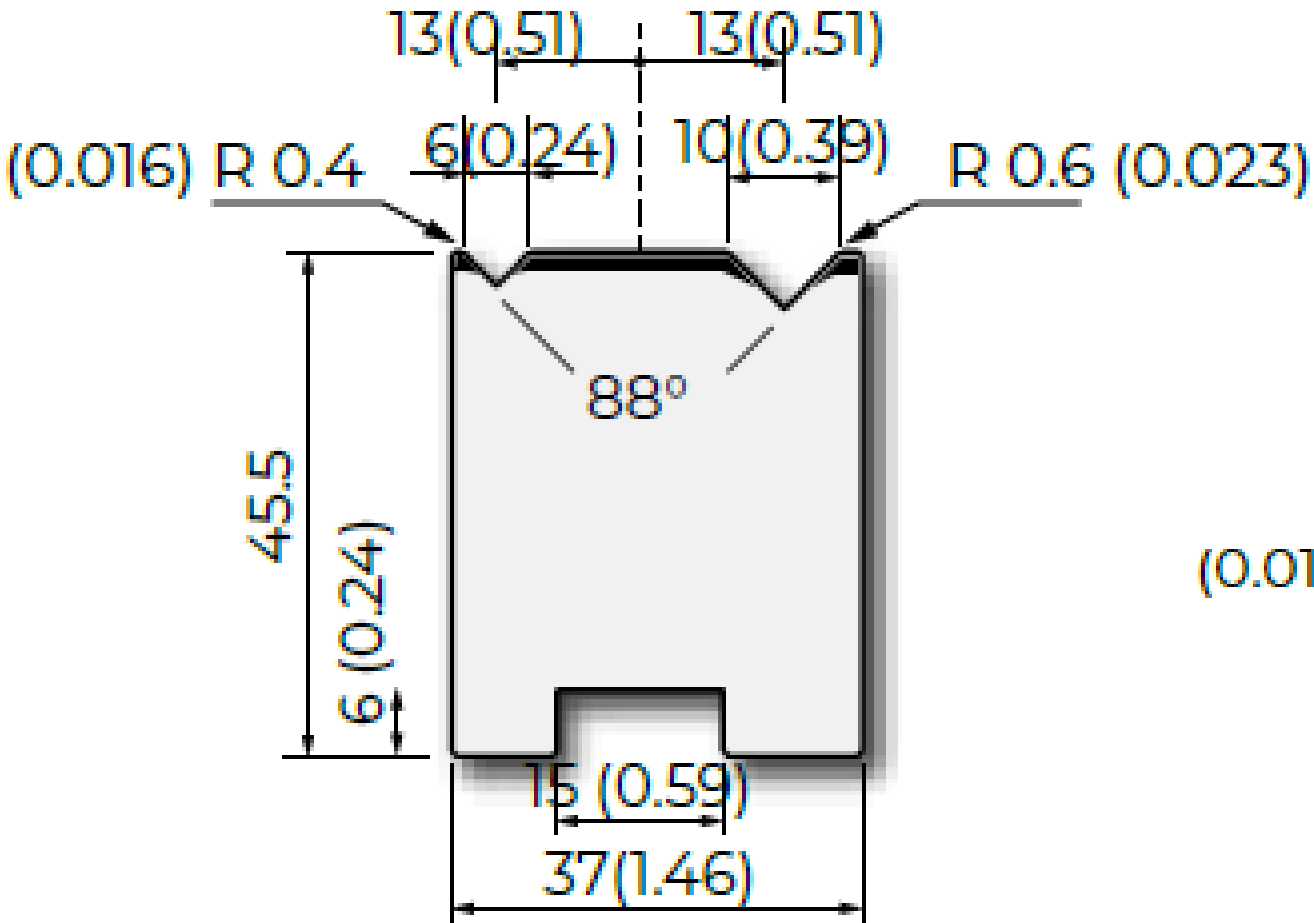

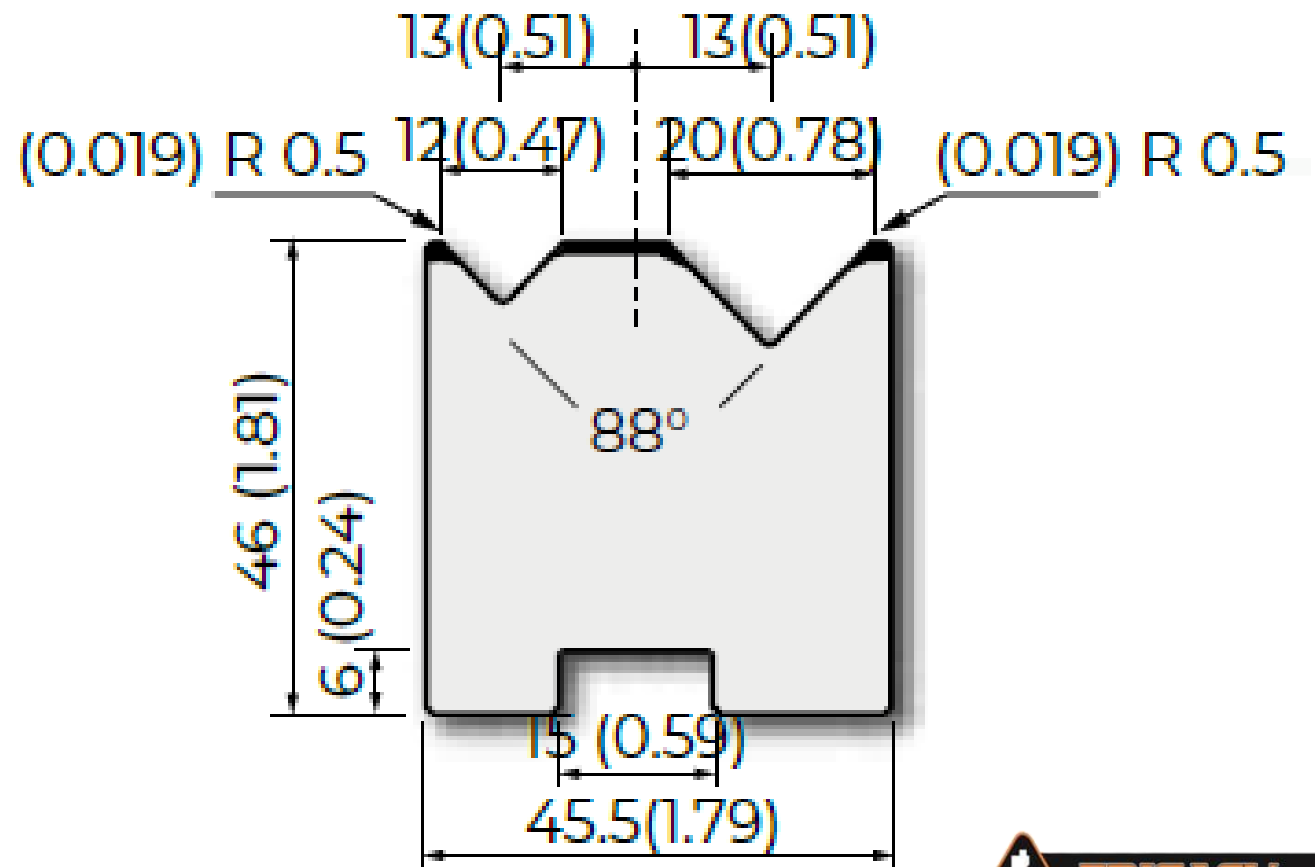
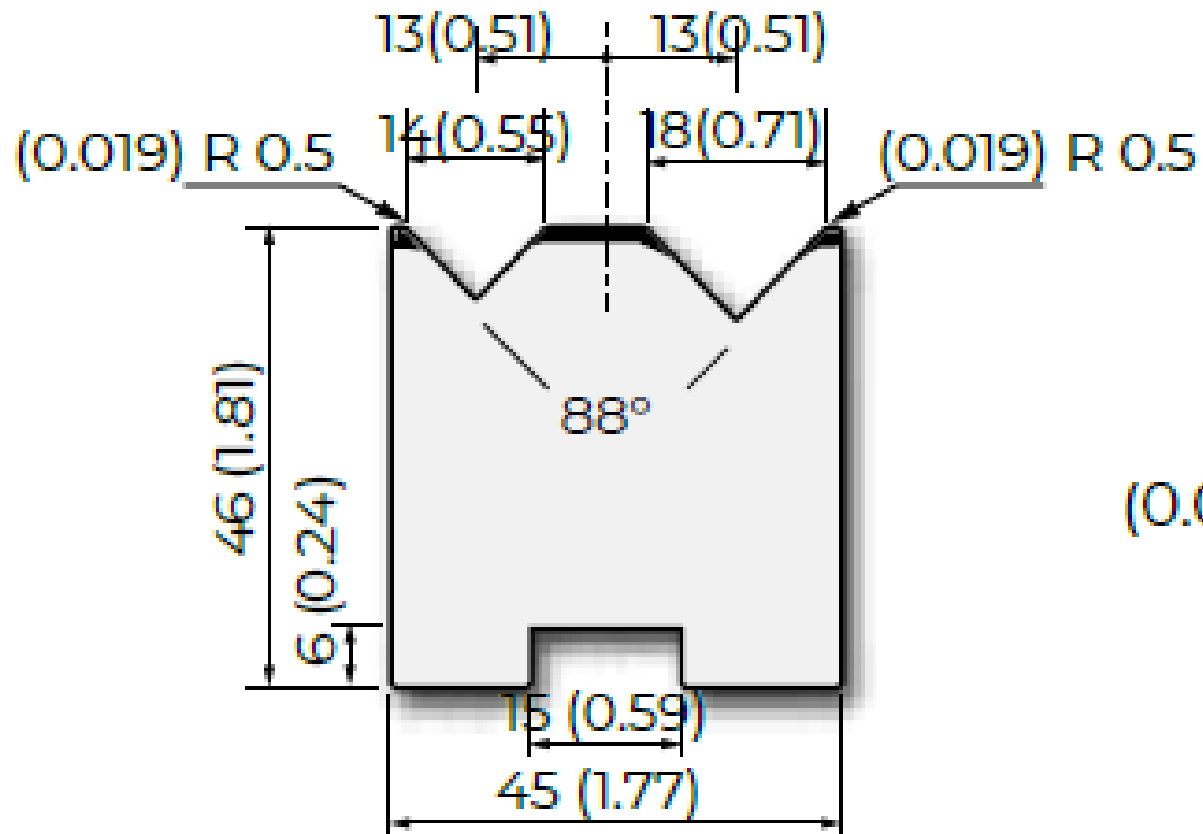

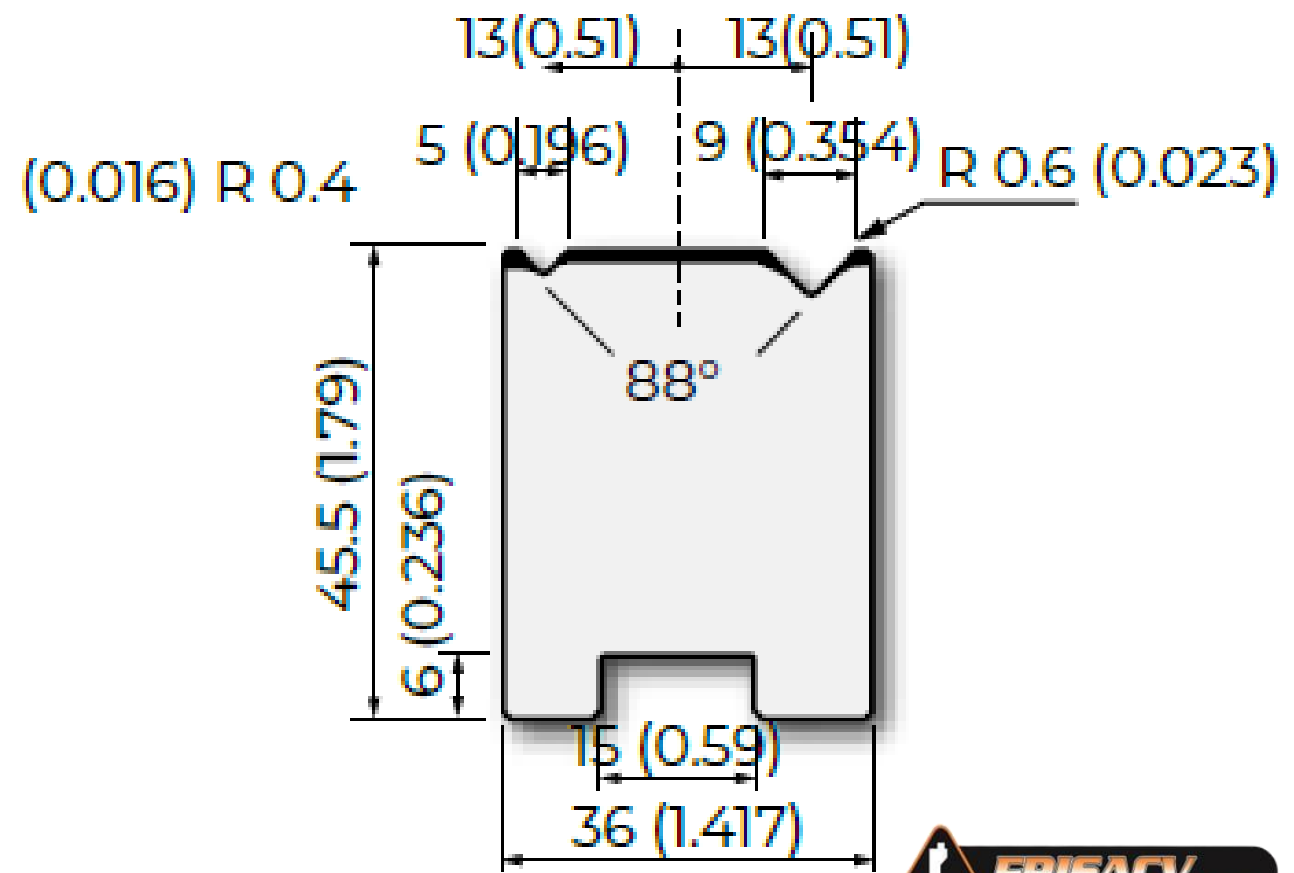
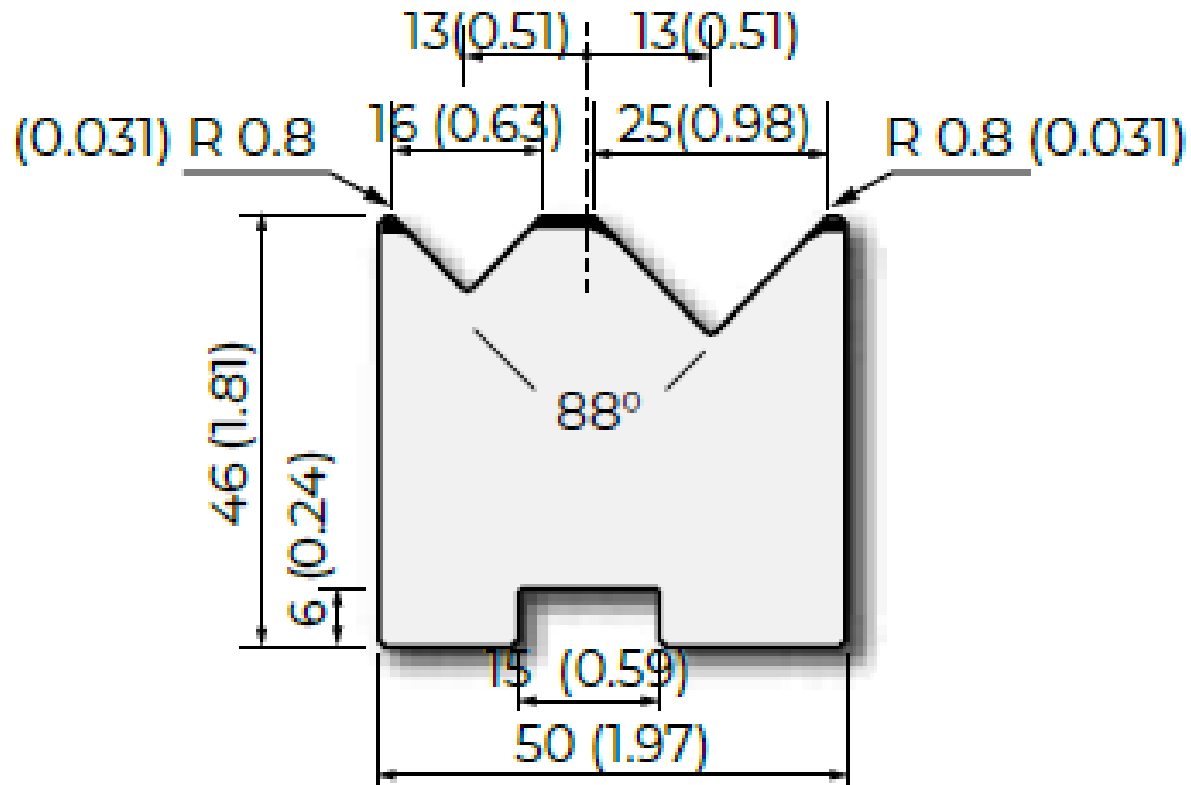

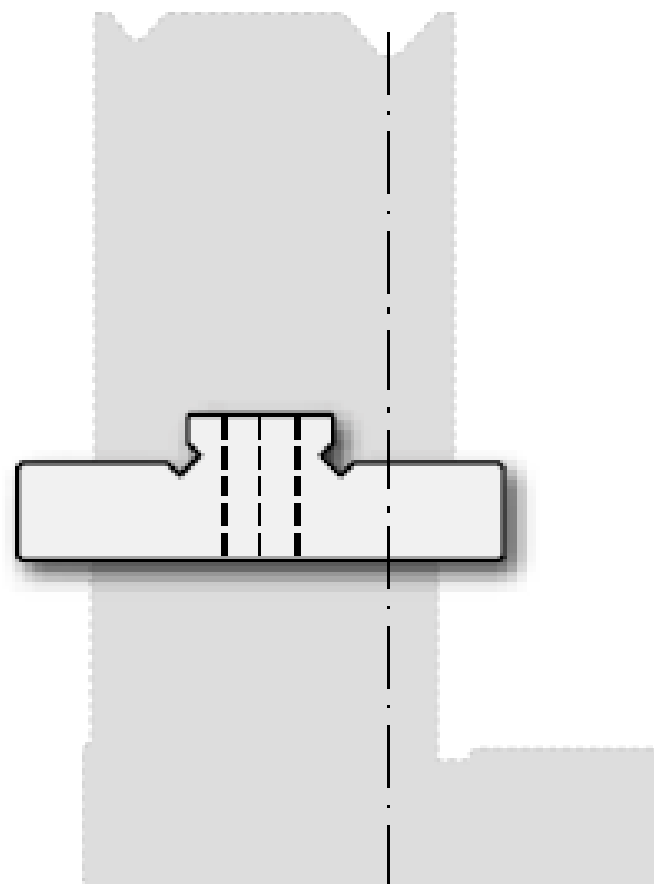
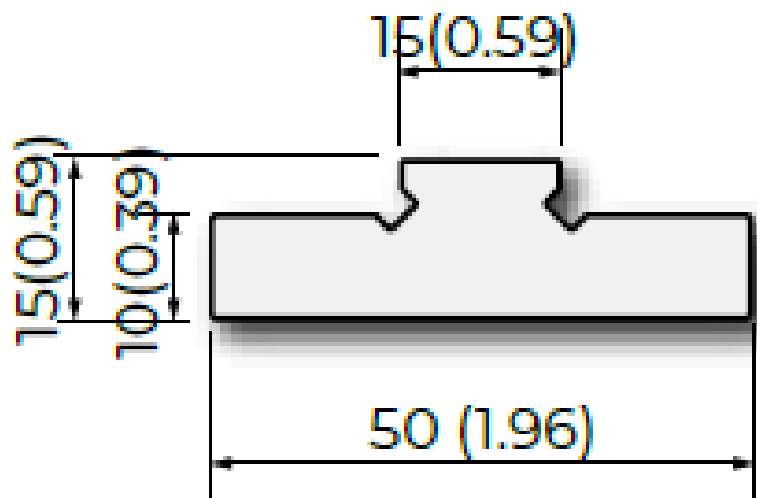

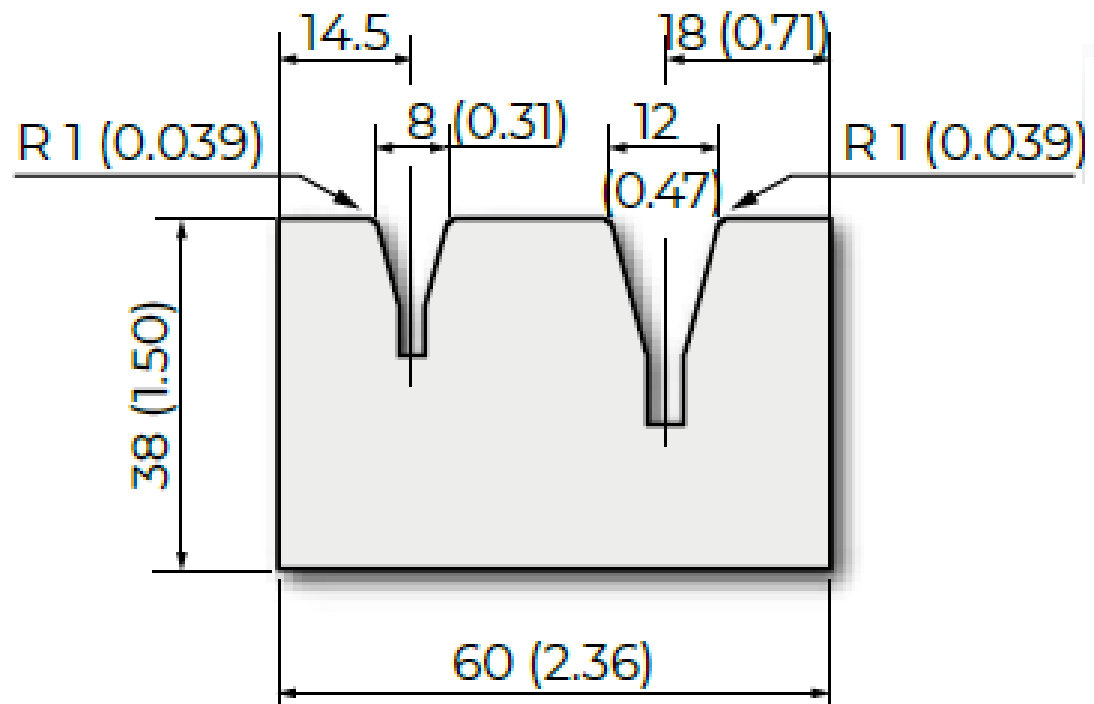

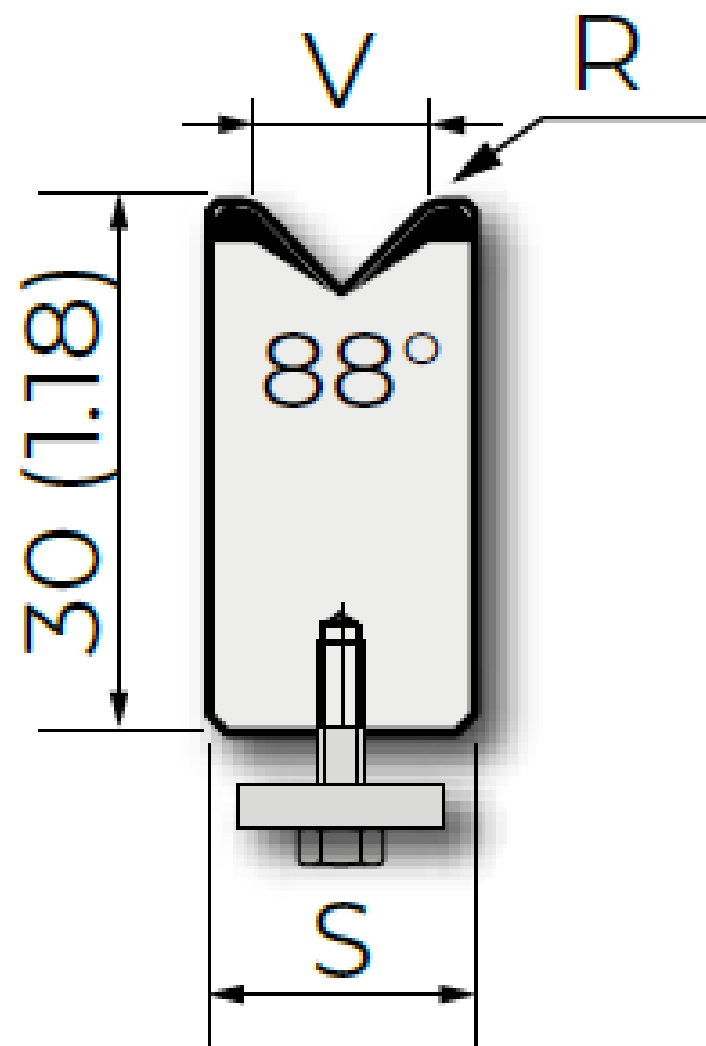
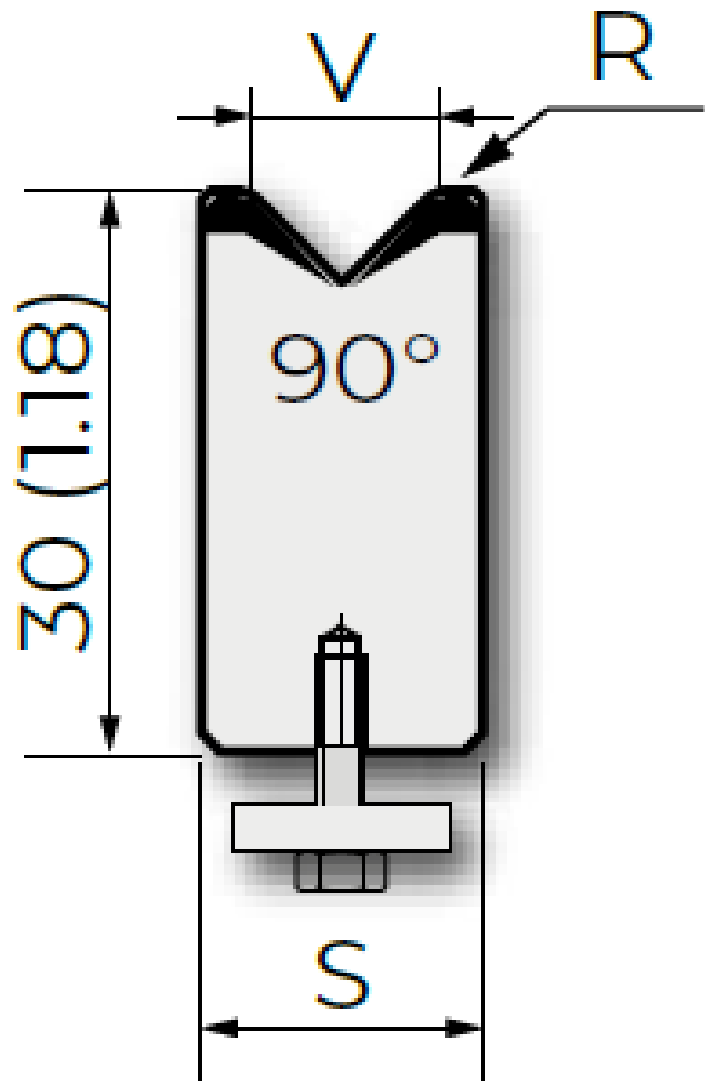

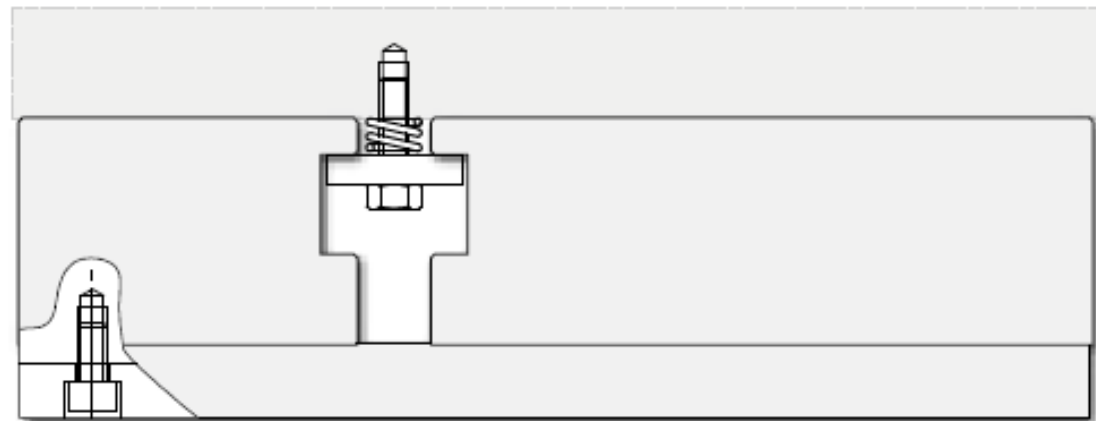
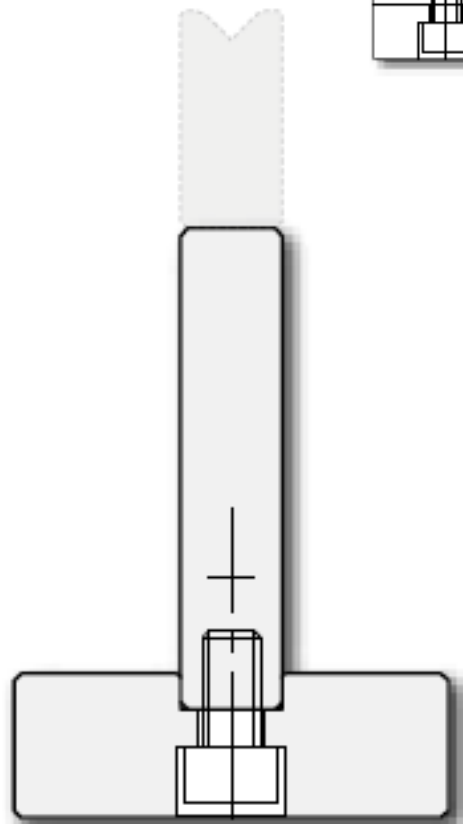
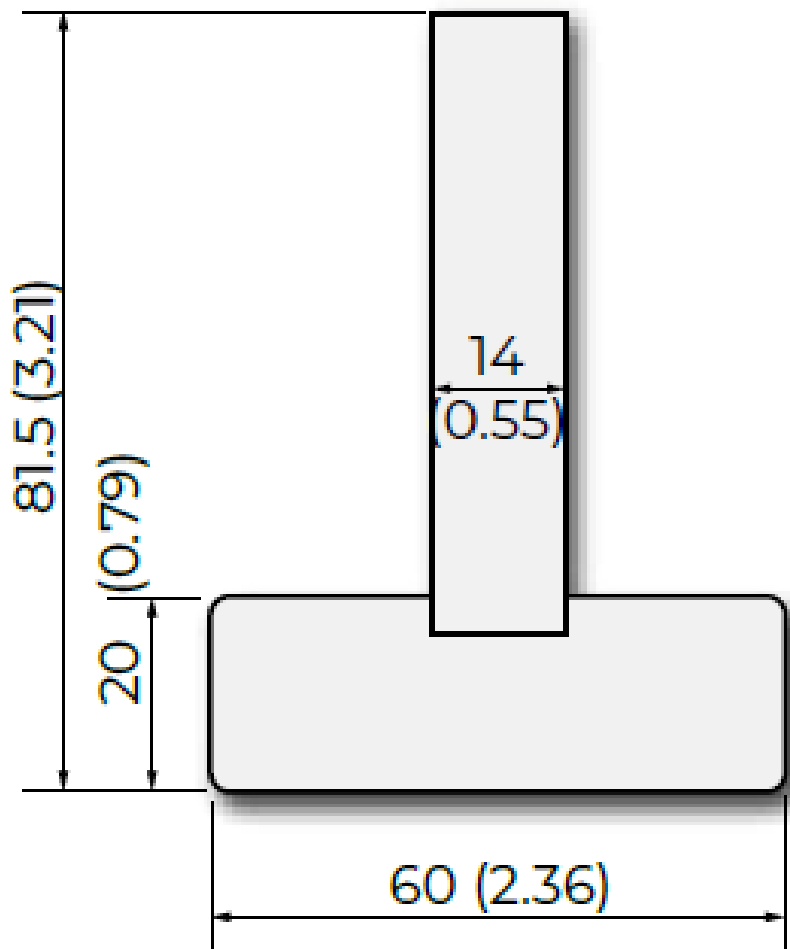

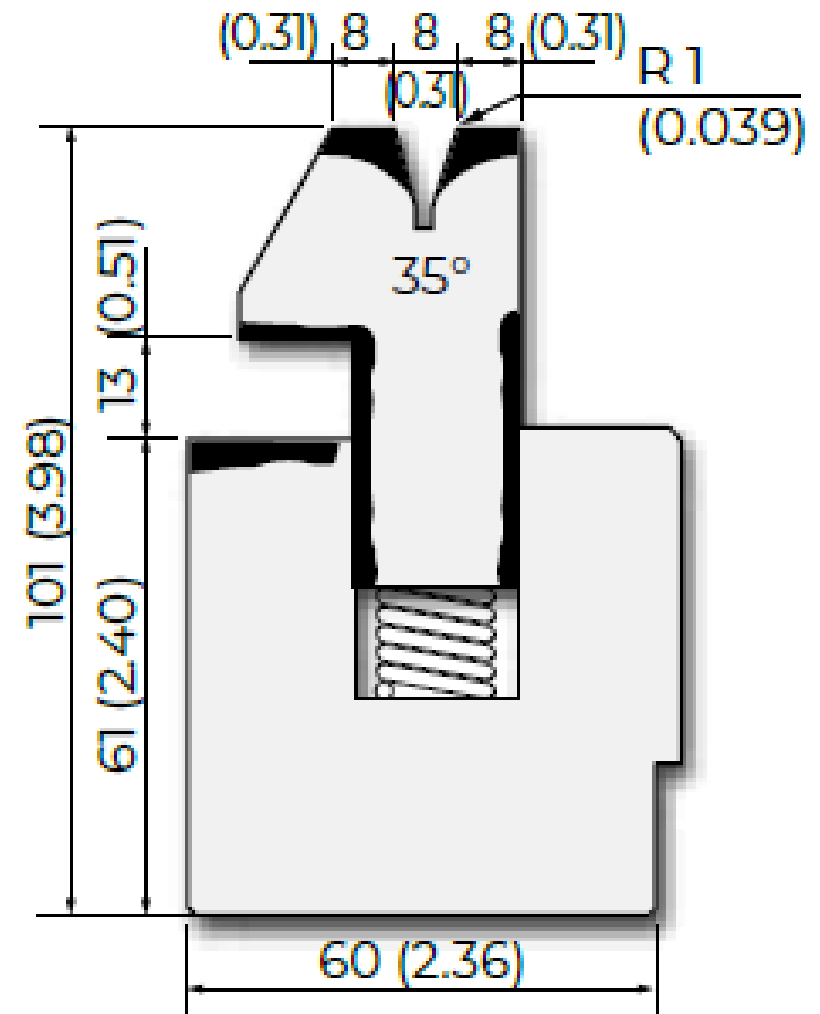
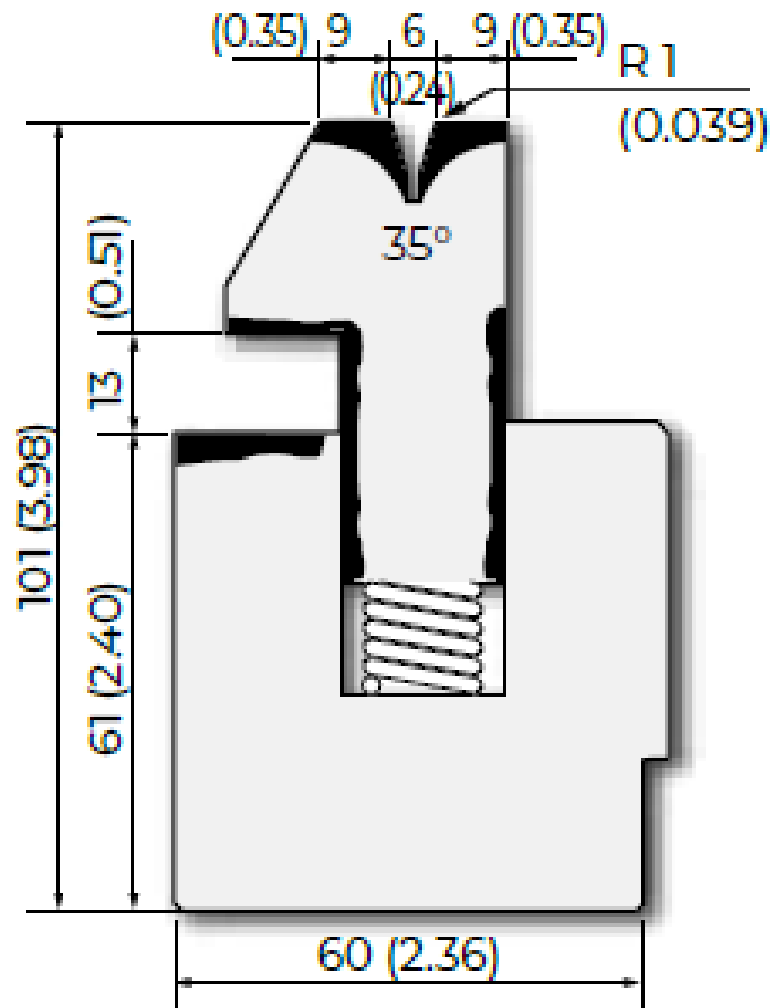

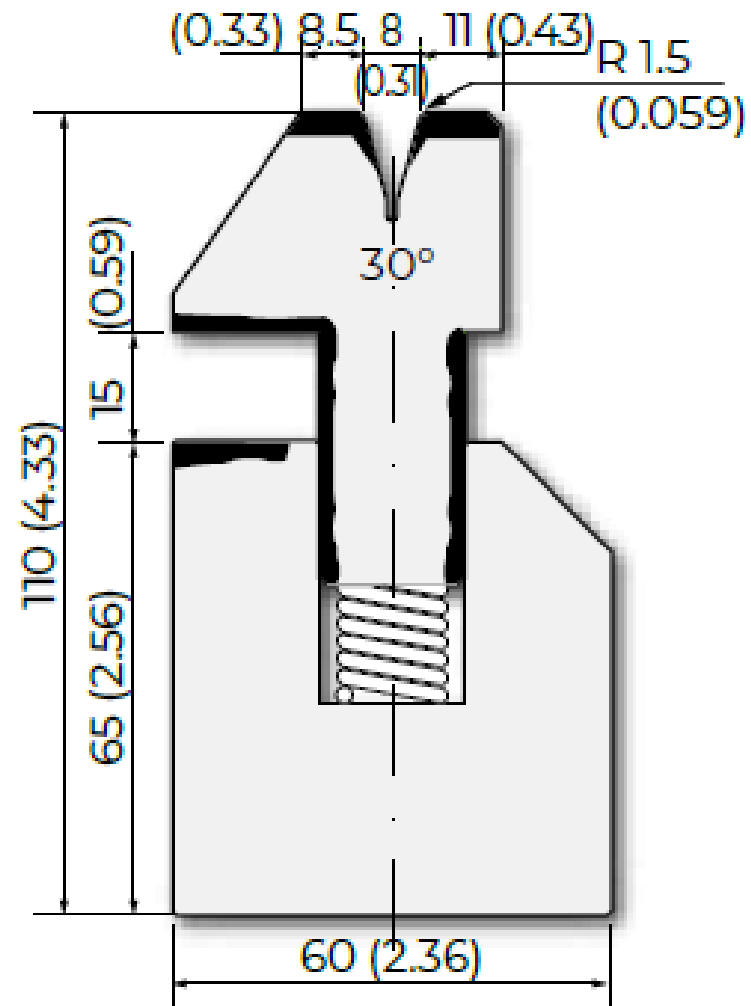
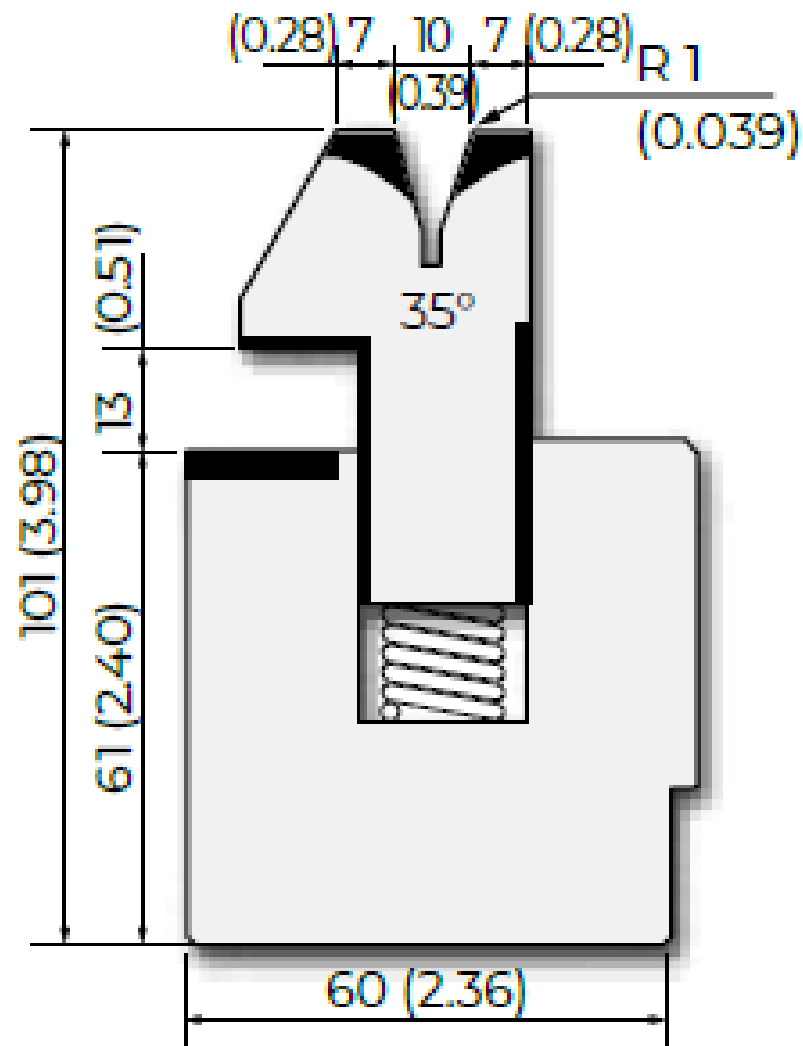

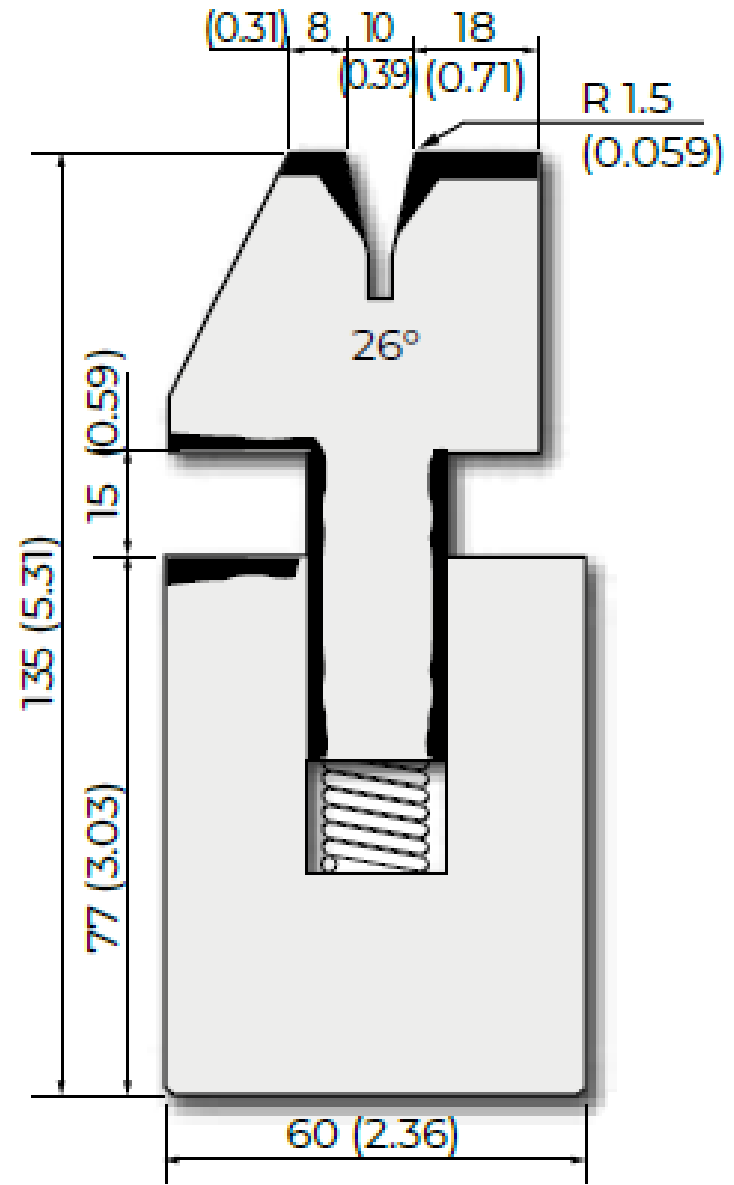
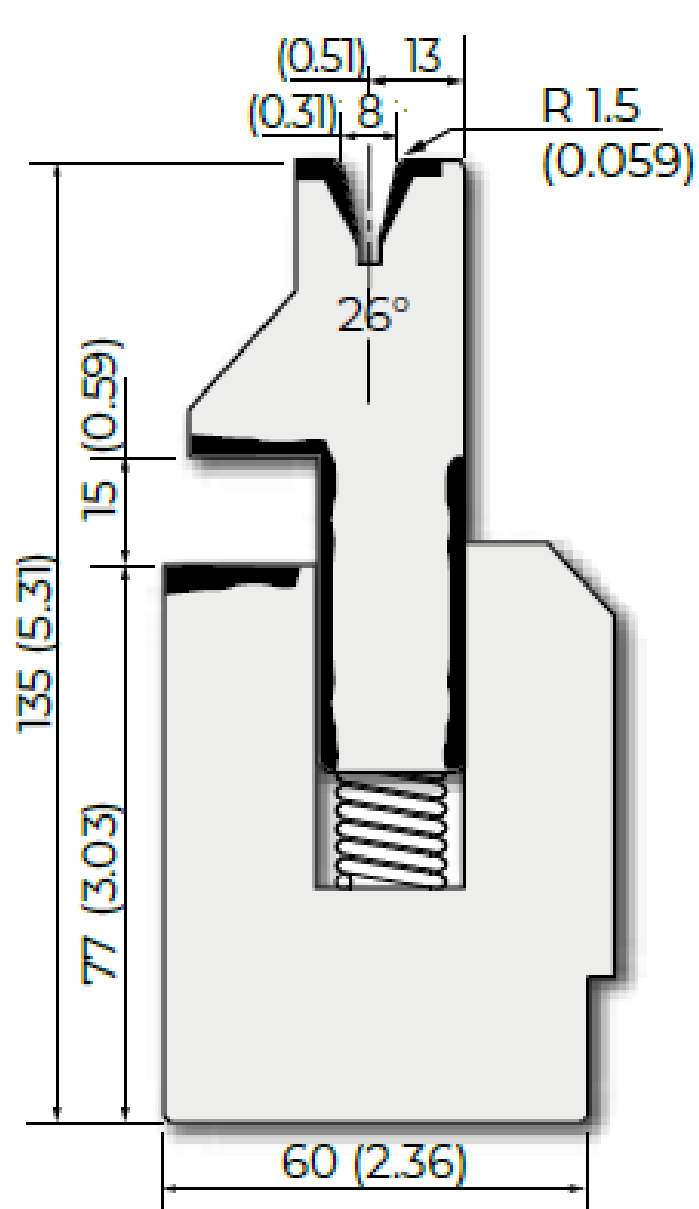

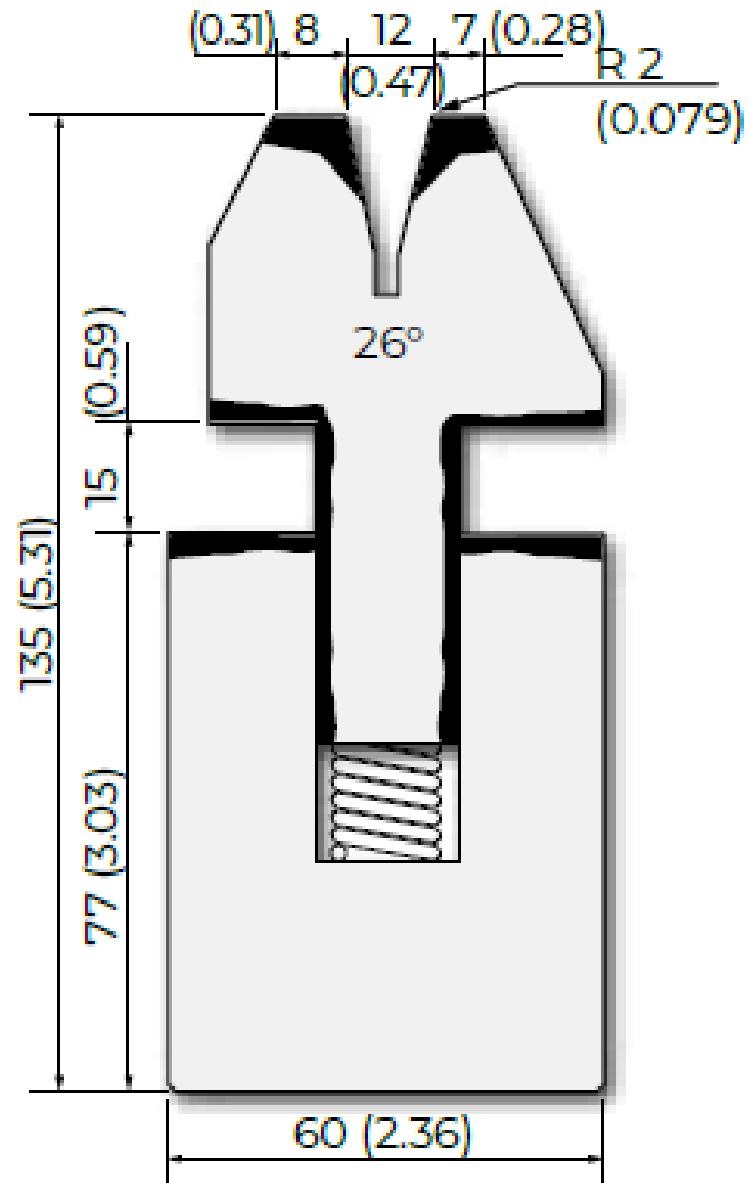

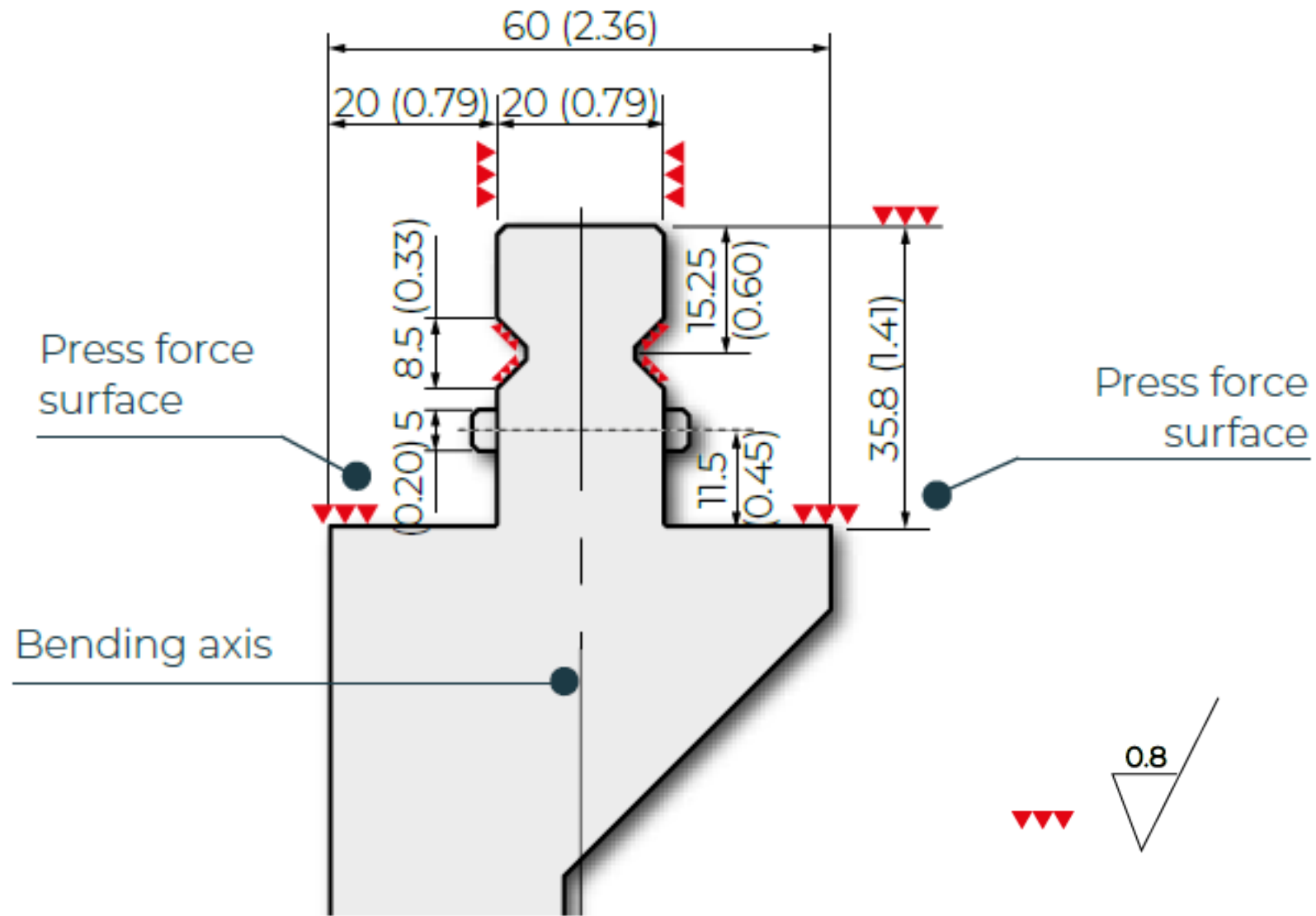

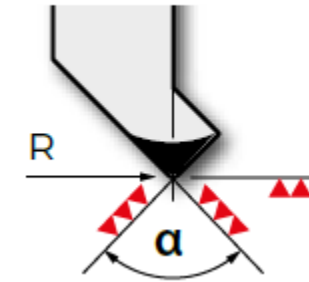
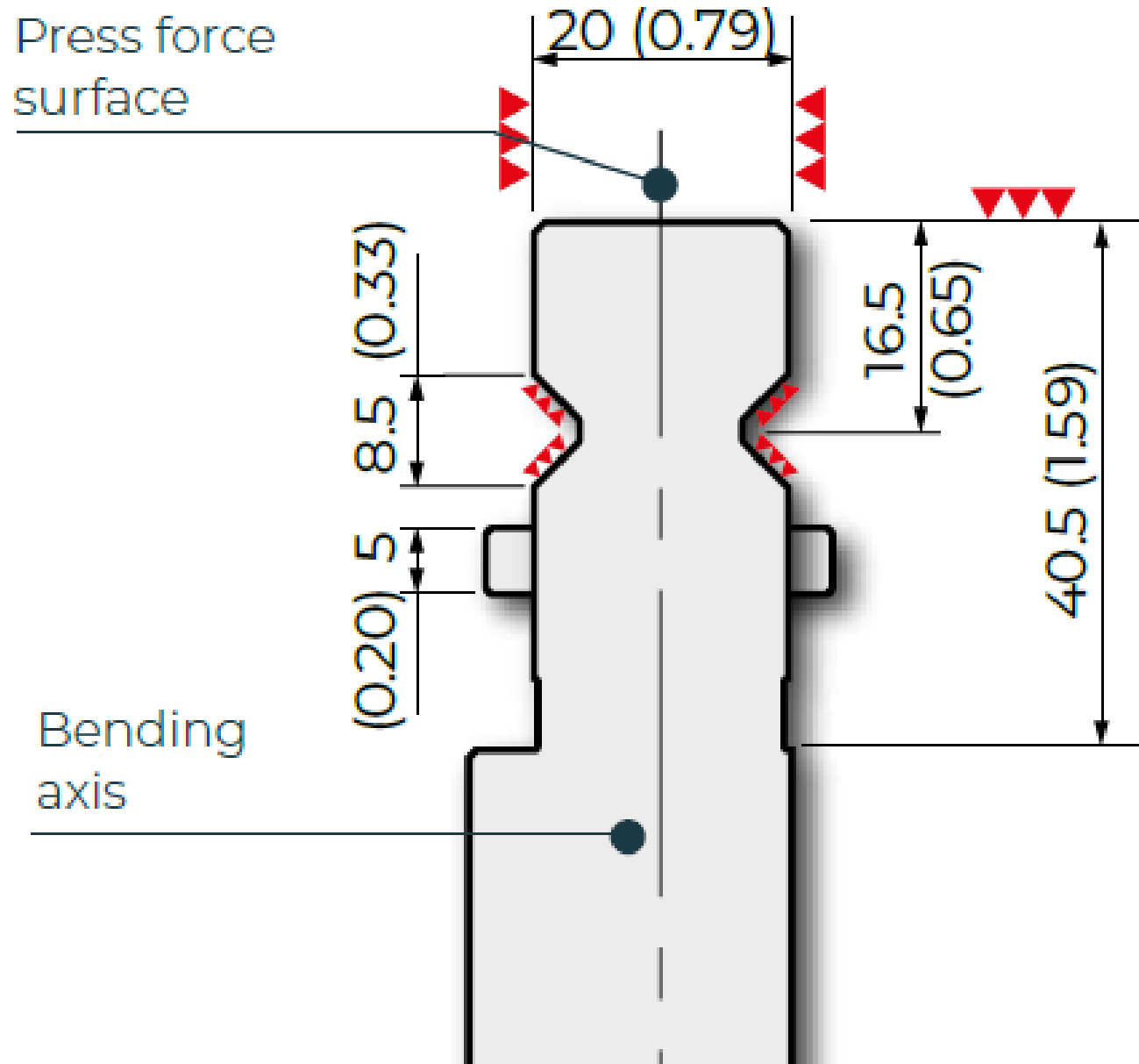

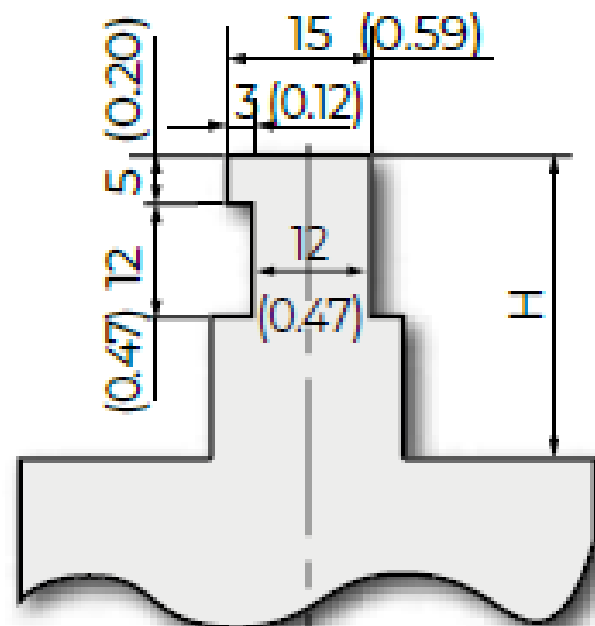
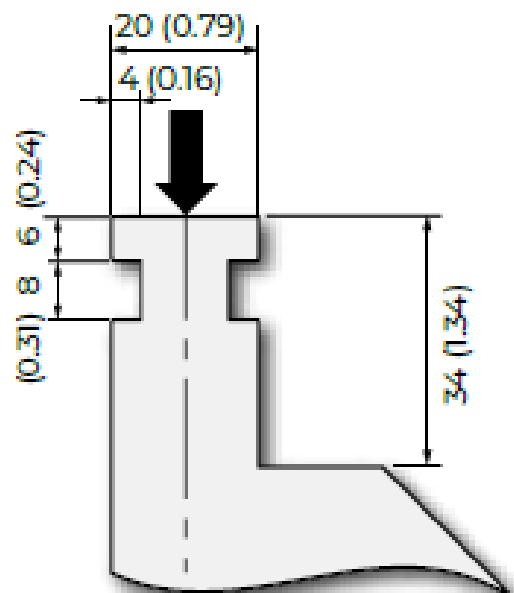
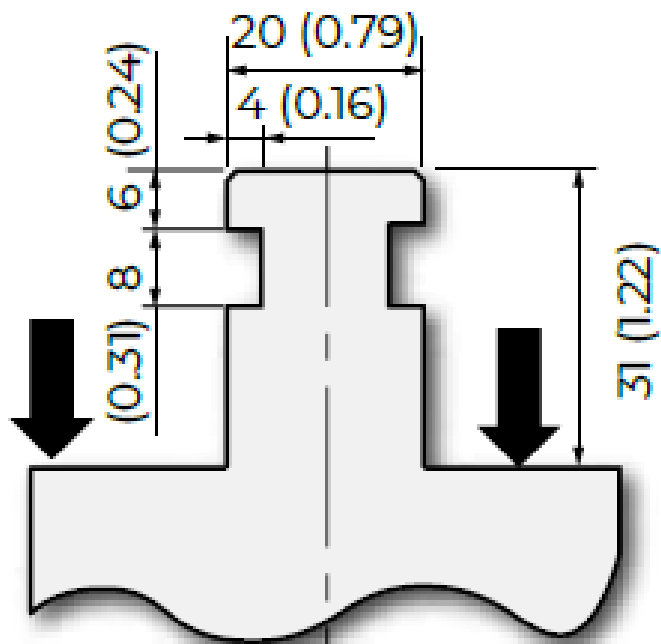

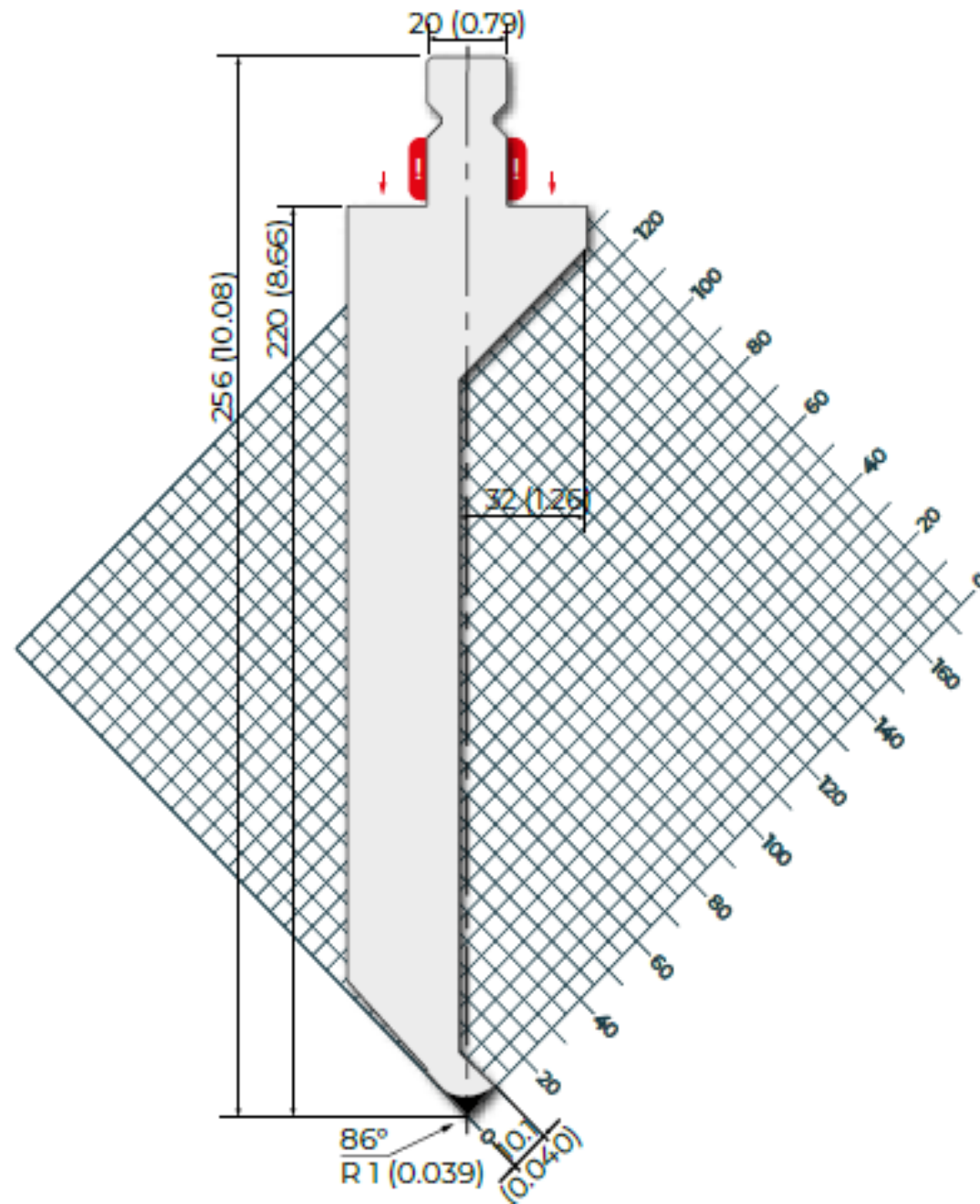

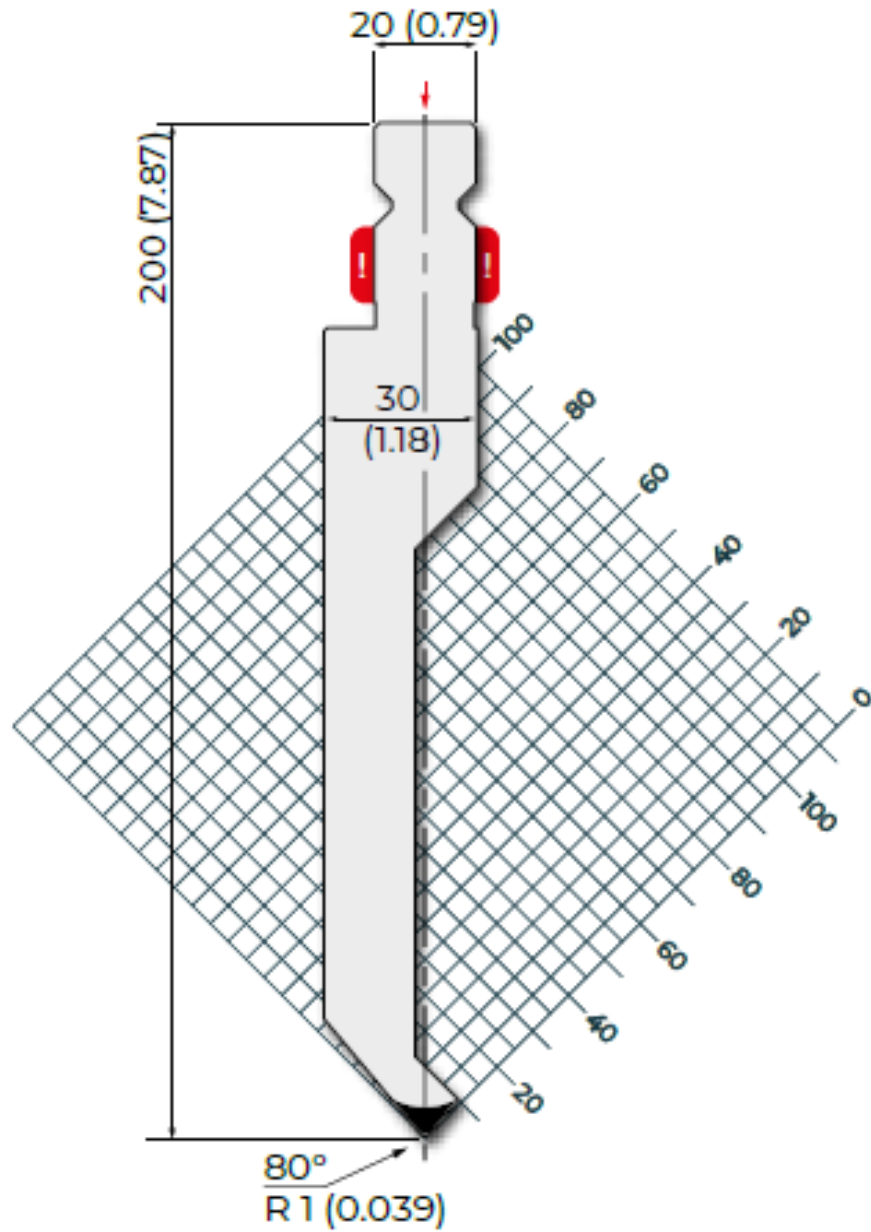

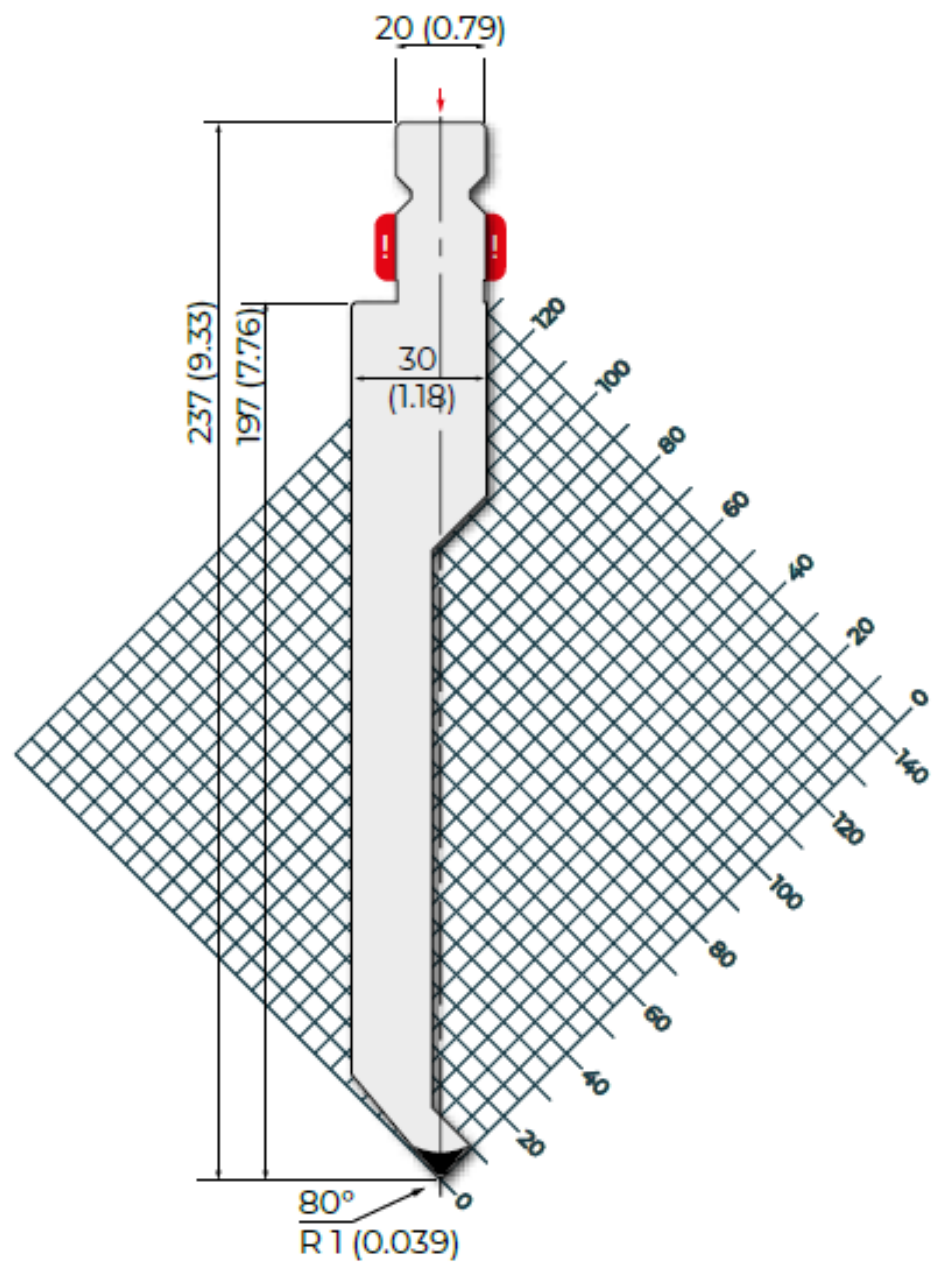

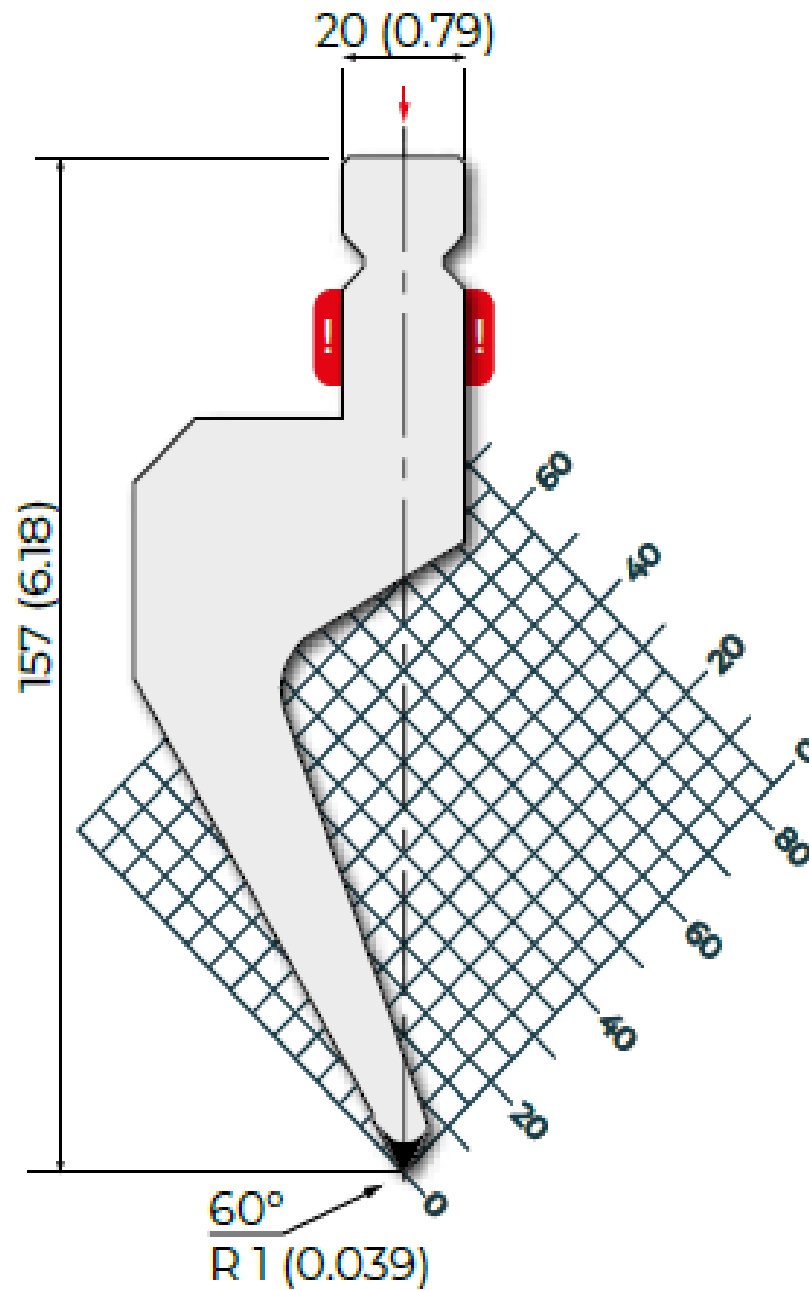

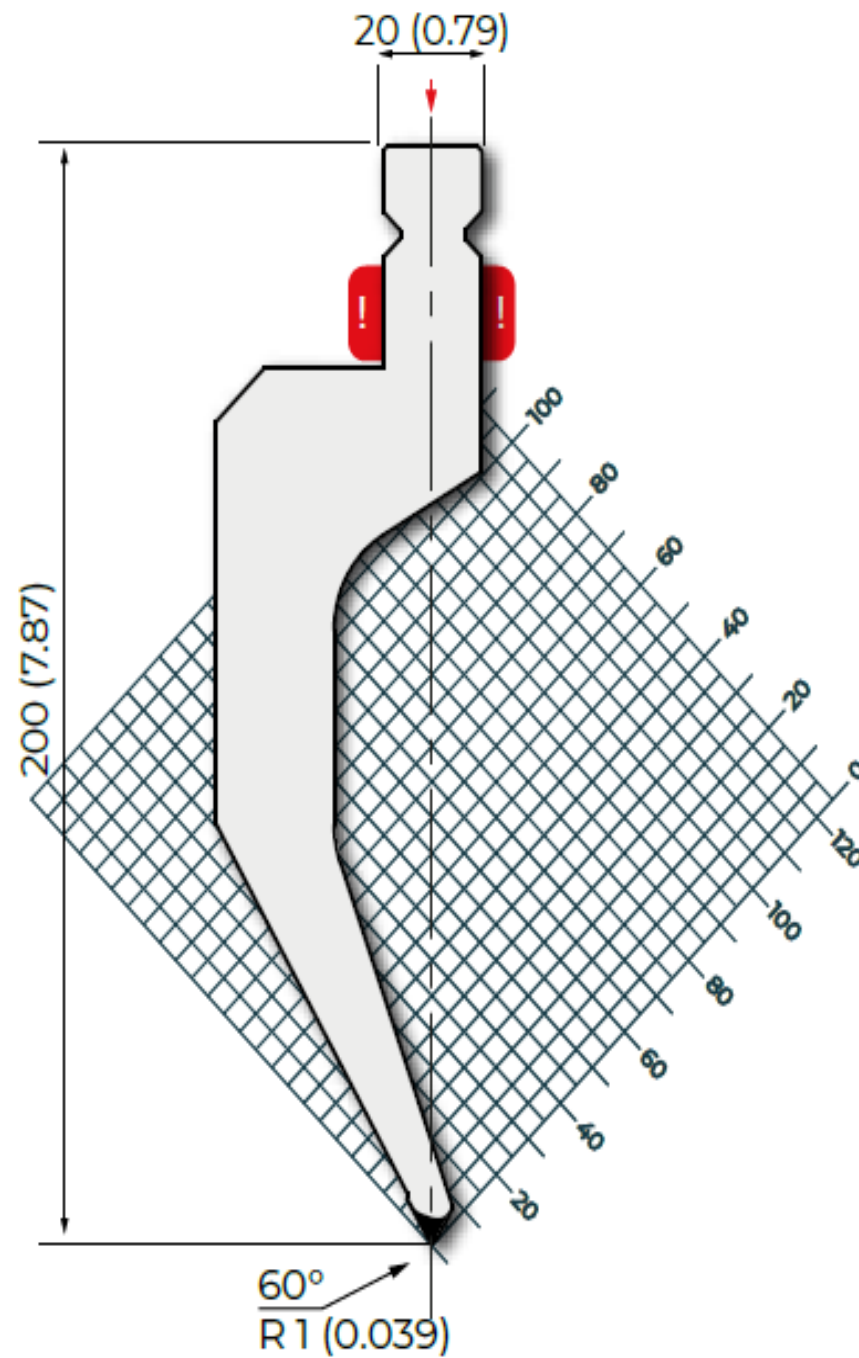

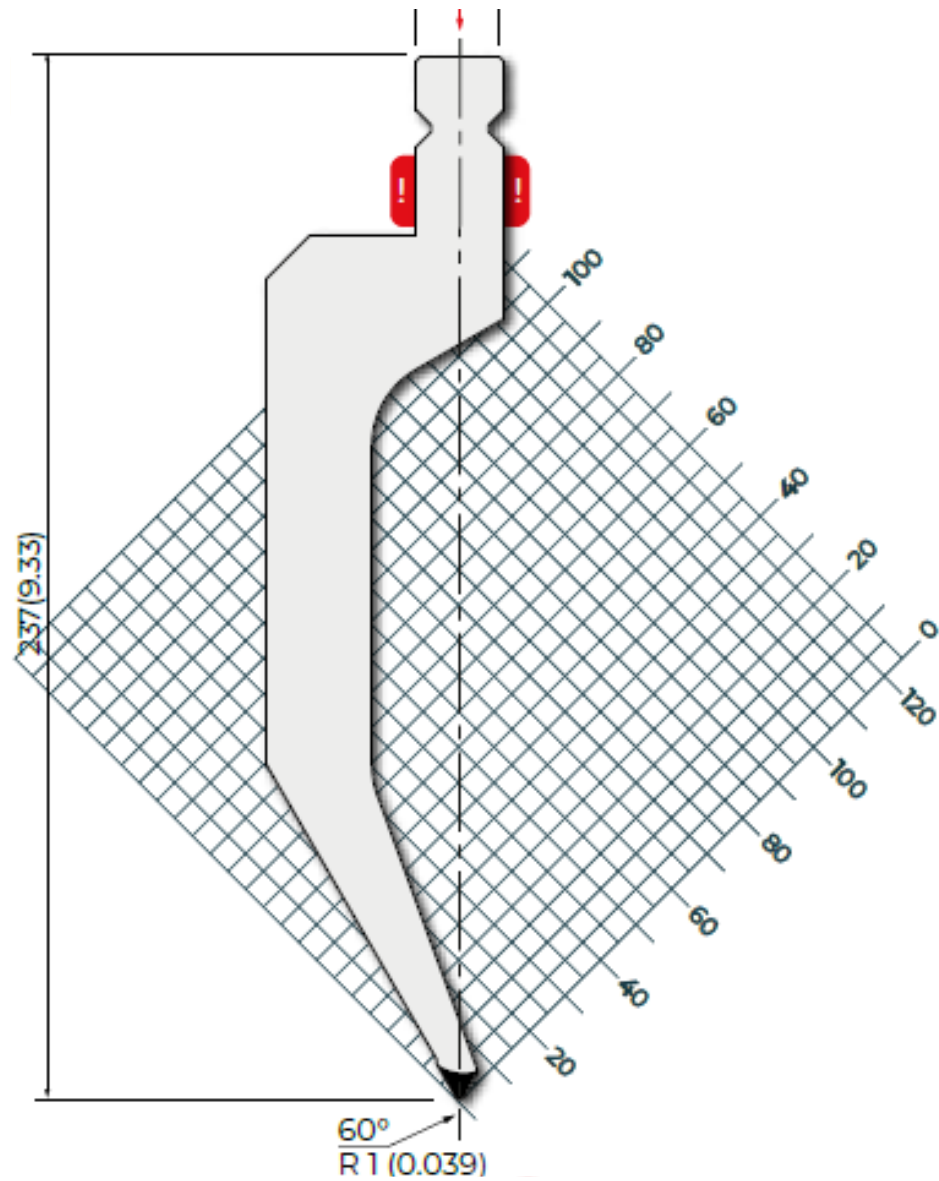

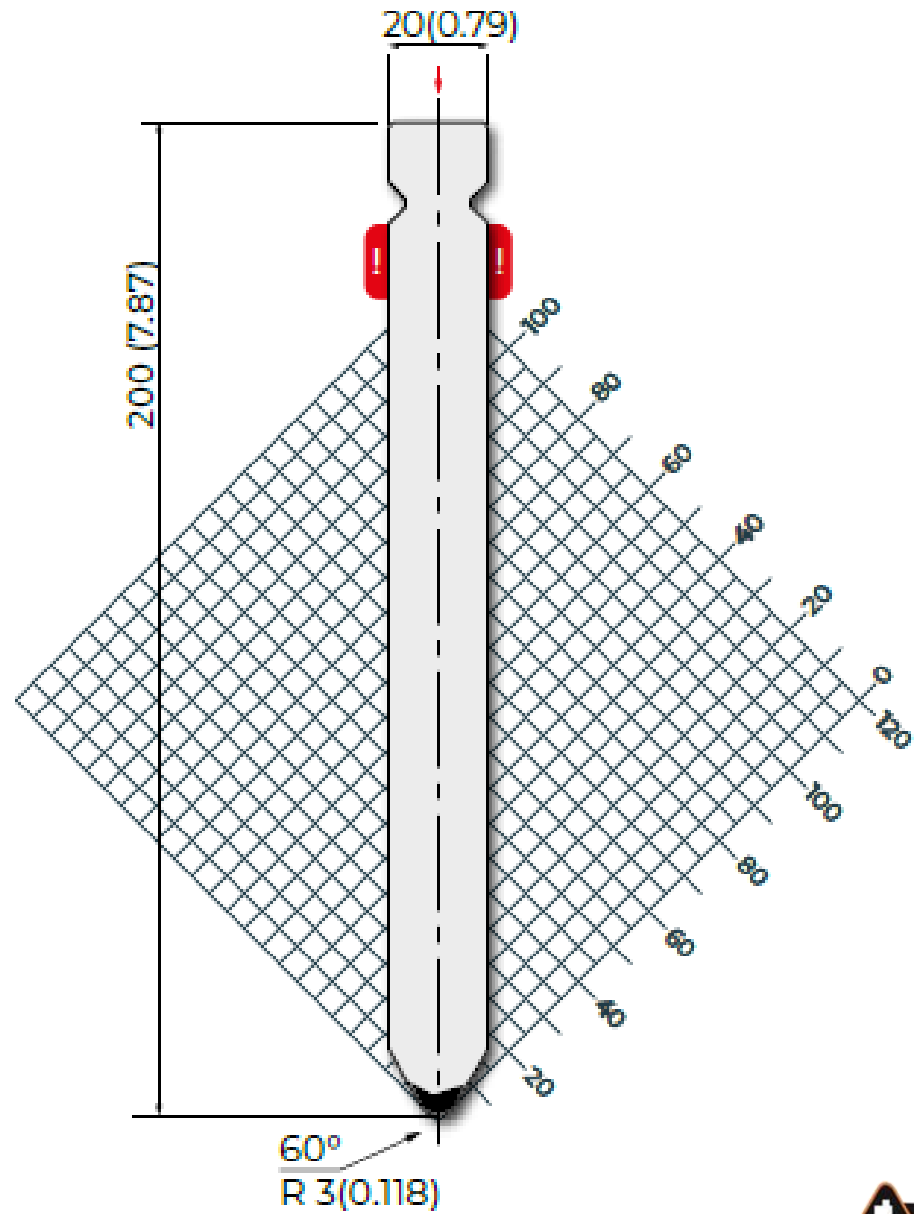
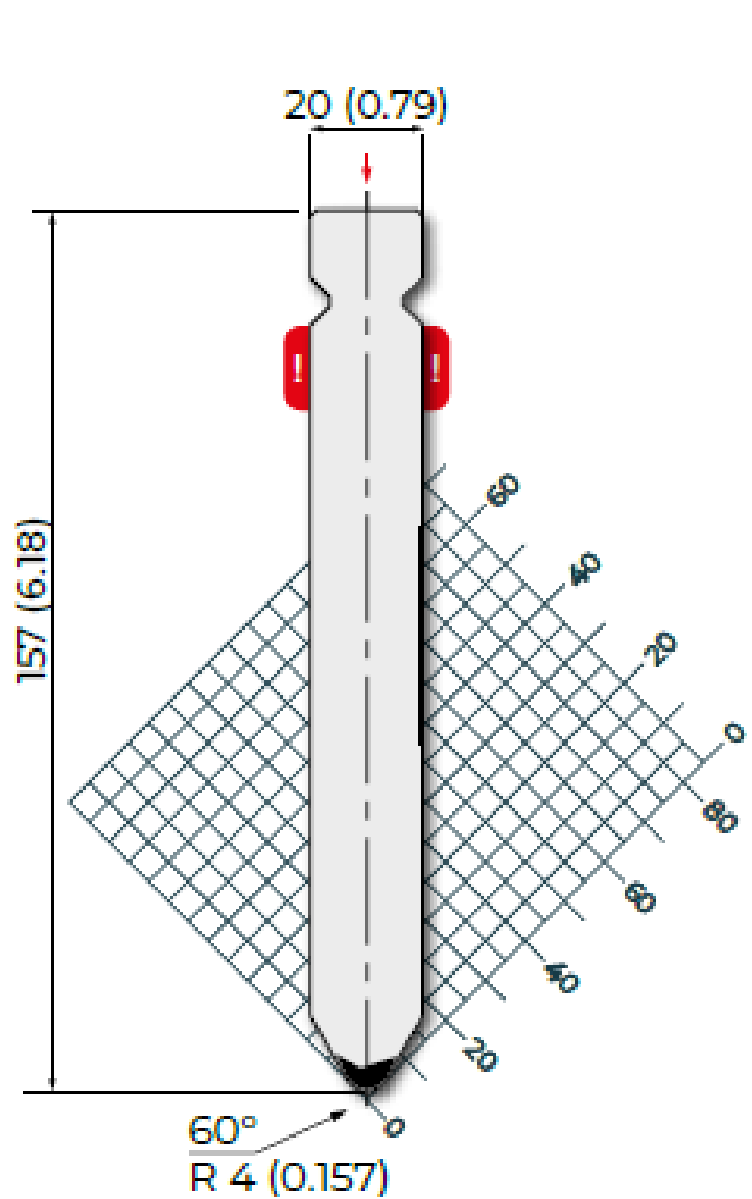

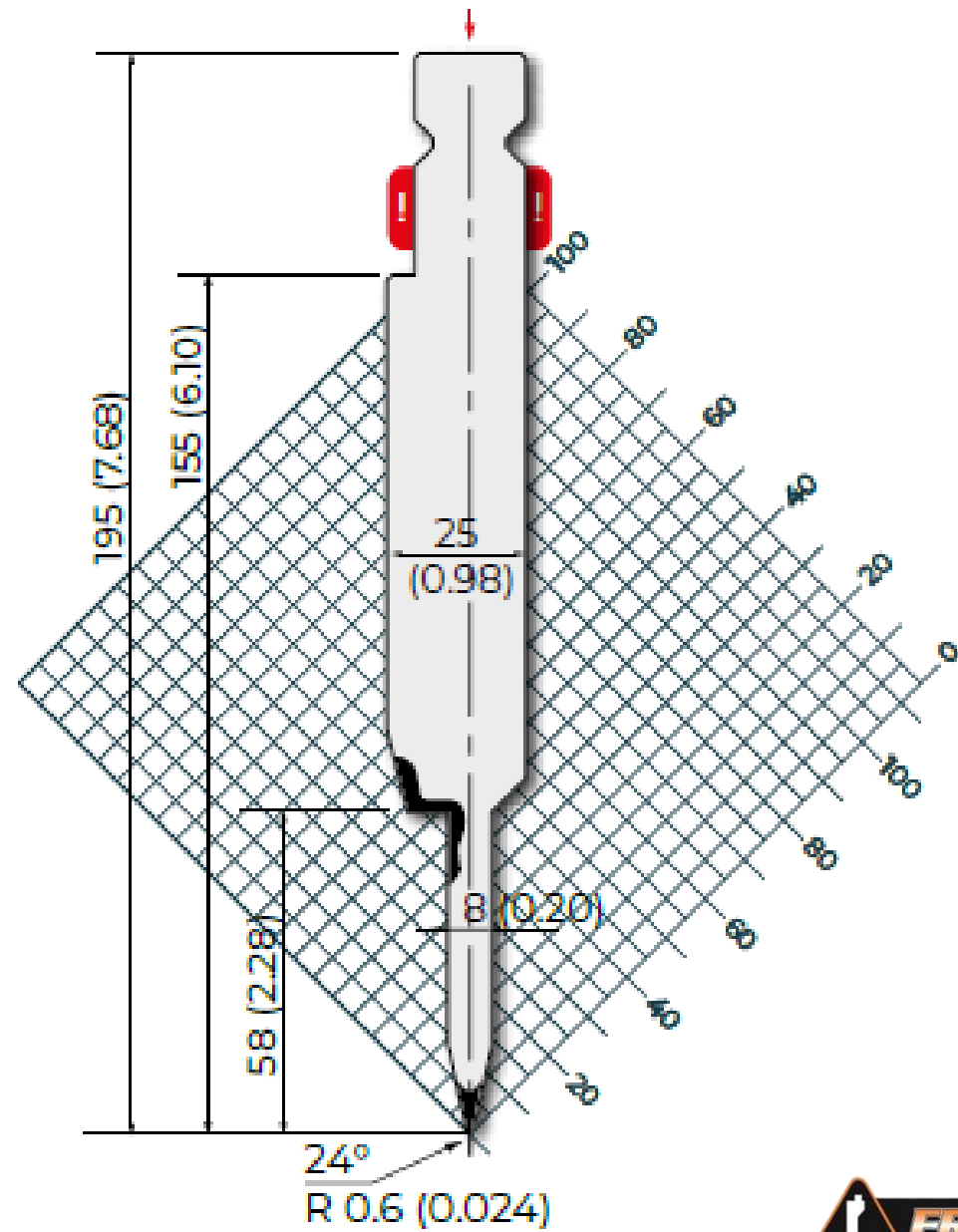
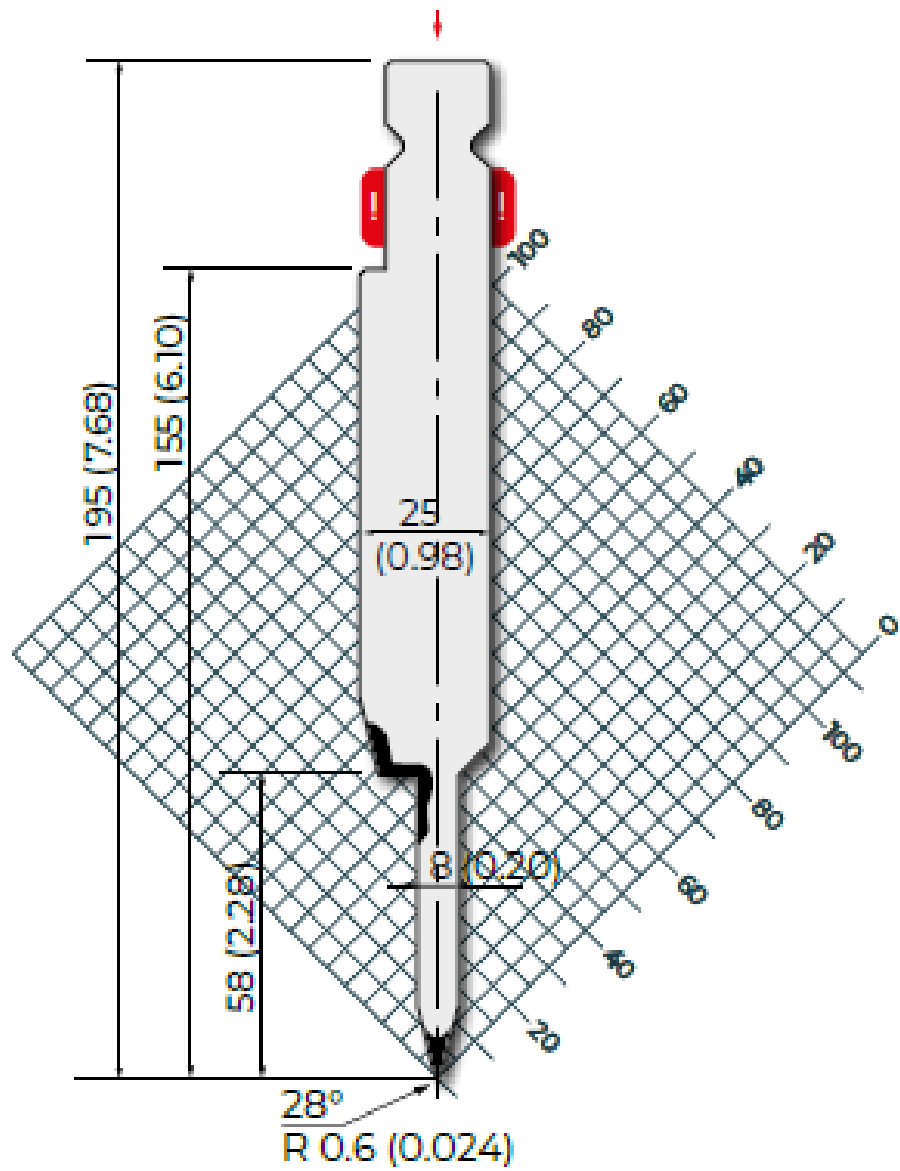

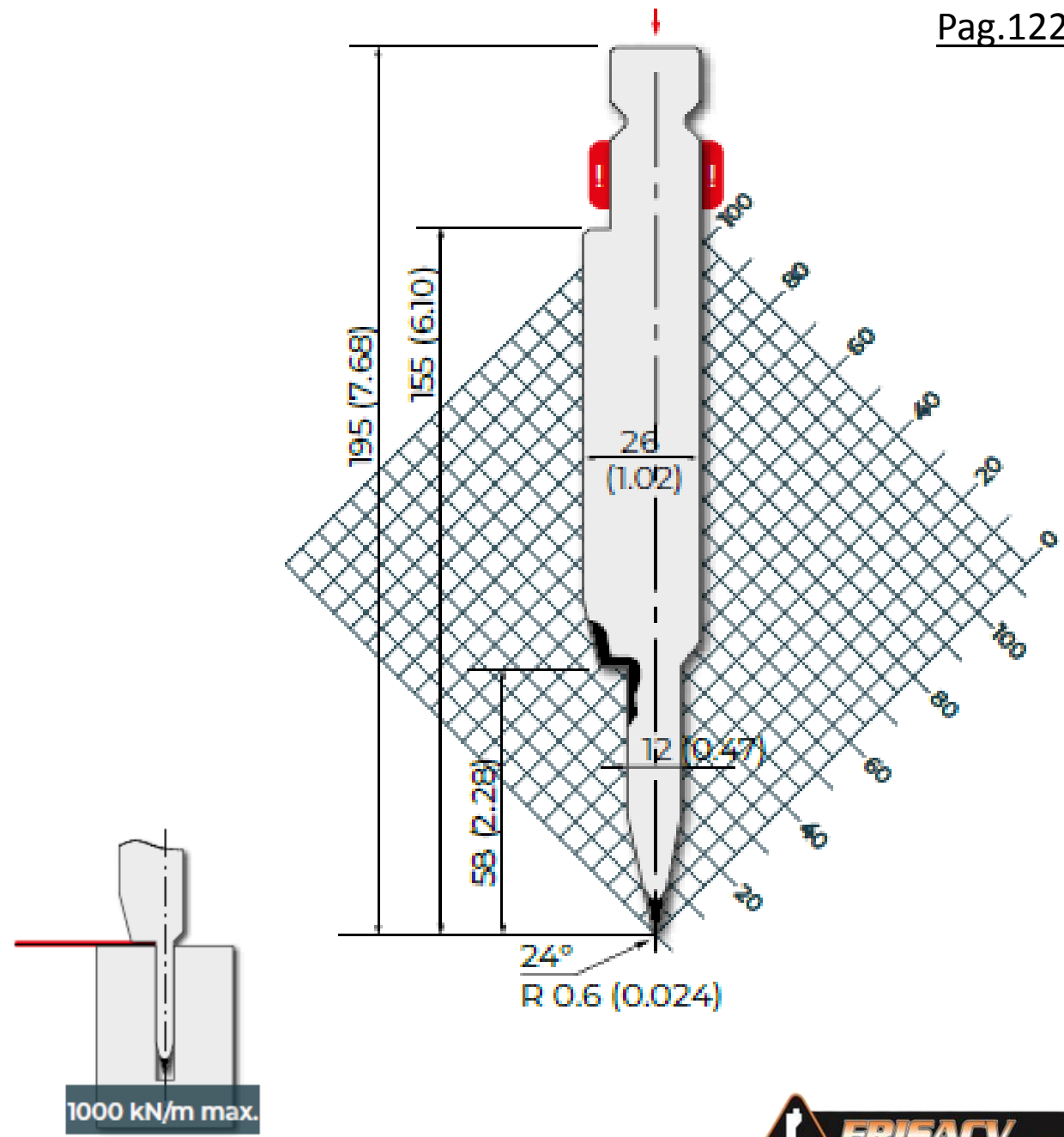
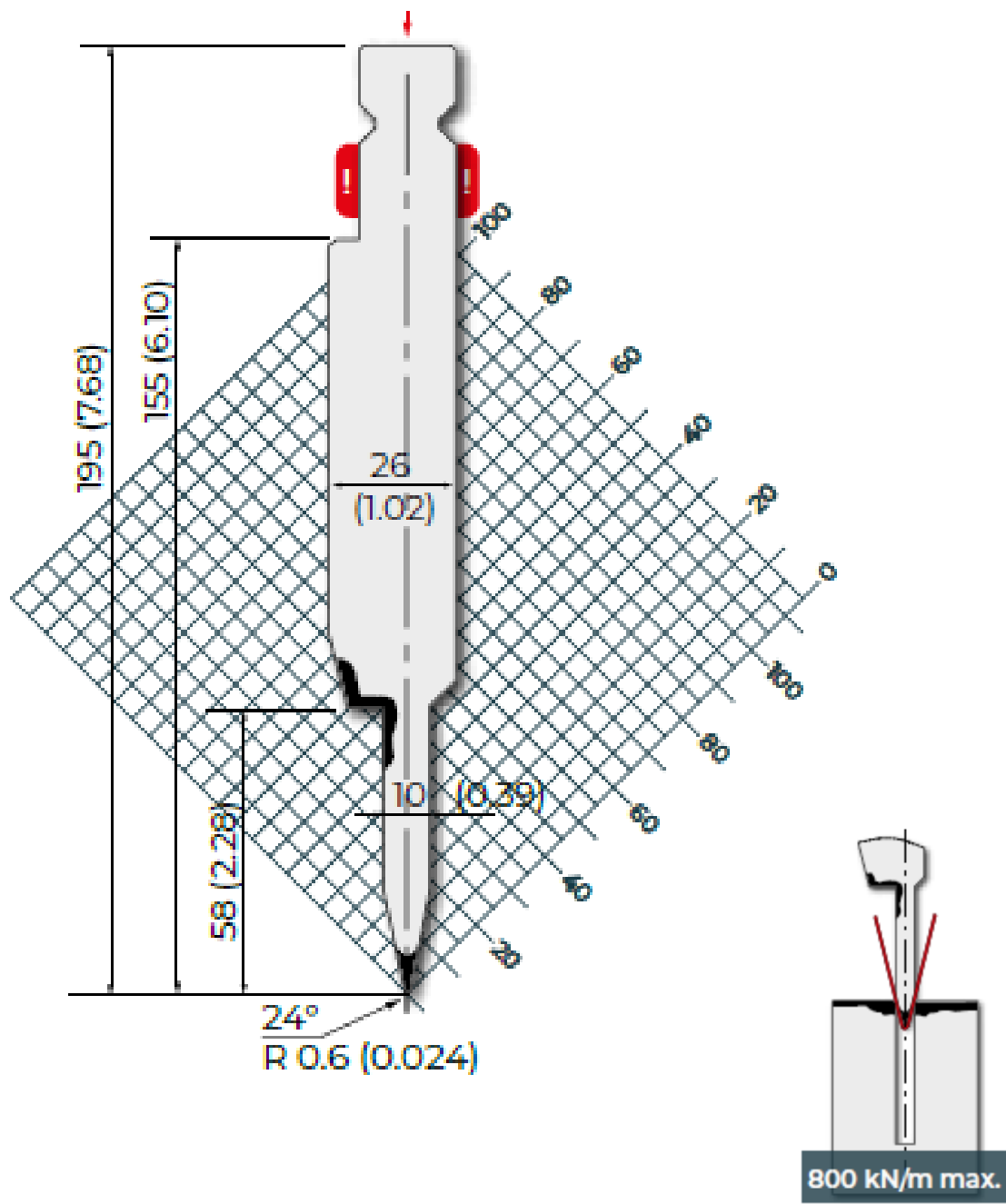



5513046183
5531972275



ventas2@frisacv.com.mx
ventas@frisacv.com.mx



55-56127386
55-56124242

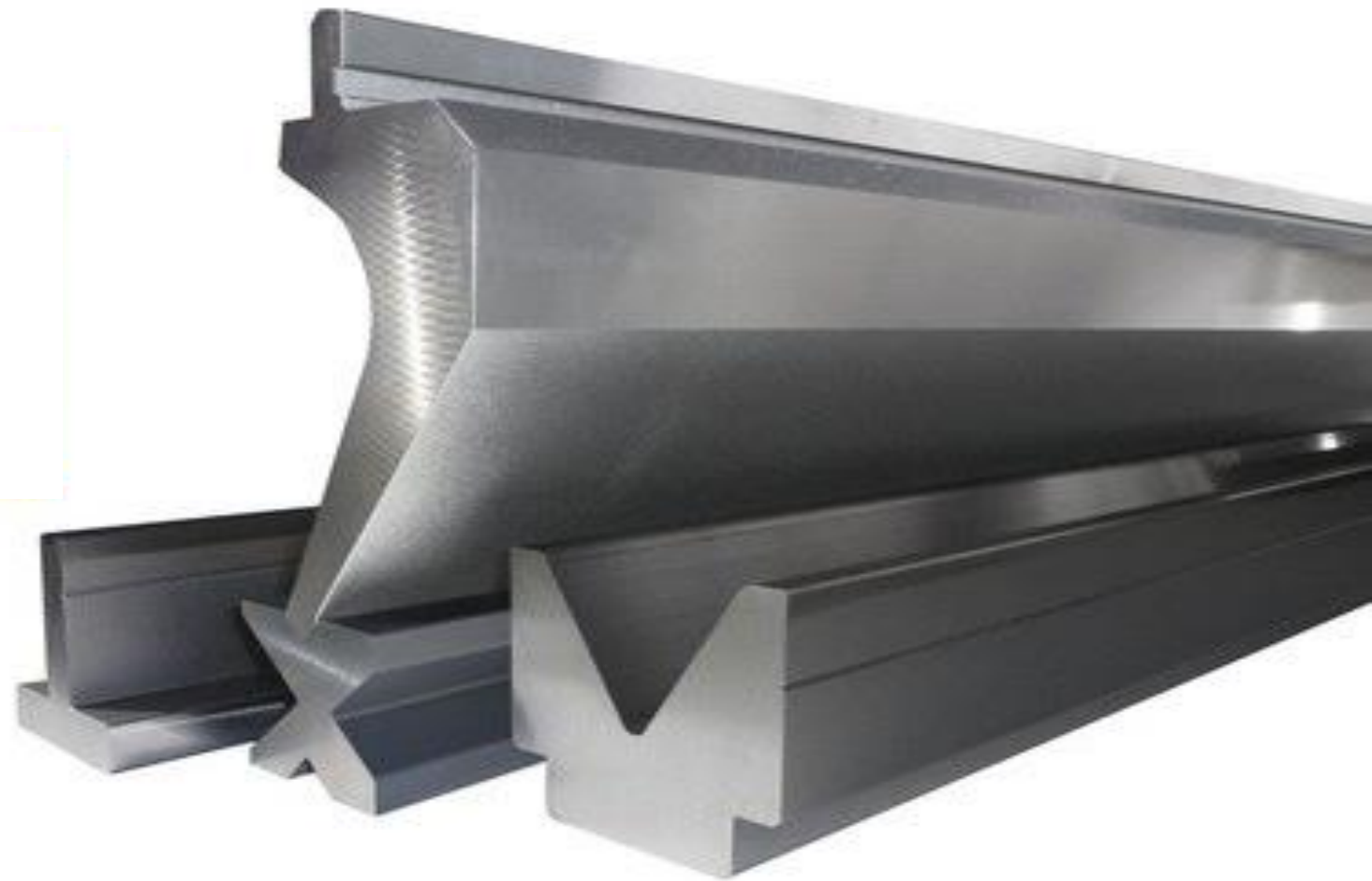

**FABRICACIÓN
DE DADOS
EUROPEOS**



CDMX 2022